

Inhoudsopgave

Achteras Aandrijving	34
Achteras Huis	116
Dashbord	102
Differentieel Slot	38
Driepunt	86
Electrisch	58
Gaskabels Voet & Handgas	4
Hef Cilinders	64
Hef Cilinders	70
Hef Electr. Regeling	74
Hef Electr. Controle Regeling	82
Hef Hydrauliek	136
Hef ventielen	66
Hydrauliek	62
Ingaande As	118
Koppeling	24
Koppelings Pedaal	26
Luchtfiler	6
Middenstuk Knikstuk	112
Motor	96
Motorkap	10
PTO	44
PTO Hydraulische & elektrische schakeling	54
PTO Koppeling	48
PTO Schakeling	46
PTO Schakel Handels	52
Radiator & Slangen	100
Remmen	28
Rem Pedaal & Handrem	30
Rolbeugel	16
Schakelpoken & Gaffels	132
Spatschermen & voetsteunen	12
Stickers	18
Tandwielen	32
Tank	8
Trekhaak	92
Vooras Aandrijving	22
Vooras Huis	20
Wiel Einvertraging	36
Wielen & Banden	146
Zitting	106

Code	Description	Notes
A0201_0_2357	ENGINE CONTROLS	
A0401_0_2427	AIR FILTER	
A0501_0_2443	FUEL TANK	
B0101_0_2468	BODY	
B0203_0_2593	MUD-GUARDS AND FLOOR BOARDS	
B0301_0_2700	ROLLBARS	
B0401_0_2718	PLATES	
C0102_0_2927	FRONT AXLE	
D0102_0_3082	FRONT TRANSMISSION	
D0201_0_3112	FRIZIONE CLUTCH	
D0301_0_3162	TRANSMISSION CLUTCH CONTROL	
D0401_0_3186	BRAKES	
D0503_0_3281	BRAKE CONTROL UNITS	
D0801_0_3420	COUNTERSHAFT AND CORRESPONDING GEARS	
D1001_0_3471	REAR TRANSMISSION	
D1102_0_3525	LATERAL REDUCTION GEARS	
D1201_0_3551	DIFFERENTIAL GEAR LOCK	
D1202_0_3587	DIFFERENTIAL GEAR LOCK (WITH ELECTROHYDRAULIC CONTROL)	
D1301_0_3604	NORMAL POWER TAKE-OFF (WITHOUT INDEPENDENT CLUTCH)	
D1302_0_3629	NORMAL POWER TAKE-OFF CONTROLS (WITHOUT INDEPENDENT CLUTCH)	
D1401_0_3649	POWER TAKE-OFF WITH INDEPENDENT CLUTCH	
D1402_0_3708	INDIPENDENT CLUTCH - POWER TAKE-OFF CONTROLS	
D1501_0_3724	P.T.O. WITH INDEPENDENT CLUTCH - DIFFERENTIAL GEAR LOCK WITH ELECTROHYDRAULIC CO	
E0101_0_3772	FRONT ELECTRICAL SYSTEM	
E0201_0_3784	ENGINE ELECTRIC SYSTEM	
F0103_0_3917	STEERING HYDRAULIC SYSTEM	
G0101_0_3995	HYDRAULIC LIFT	
G0302_0_4169	ONE ADDITIONAL CONTROL VALVE FOR "AR"	
G0303_0_4180	TWO OR THREE ADDITIONAL CONTROL VALVES FOR "AR"	
H0101_0_4286	ELECTRONIC CONTROL LIFT (LIFT SUPPORT)	
H0202_0_4405	ELECTRONIC CONTROL LIFT (HYDRAULIC SYSTEM)	
H0302_0_4484	1 OR 2 ADDITIONAL CONTROL VALVES FOR "AR" WITH ELECTR. LIFT	
H0401_0_4504	ELECTRONIC CONTROL LIFT (ELECTRICAL SYSTEM)	
I0102_0_4552	AUXILIARY CONTROL VALVES FOR "AR"	

Code	Description	Notes
L0201_0_4601	ATTACHMENT HITCH (BASIC VERSION)	
L0202_0_4630	ATTACHMENT HITCH (VARIANT)	
L0203_0_4662	ATTACHMENT HITCH (STRAIGHT ARMS VERSION)	
L0301_0_4690	ATTACHMENT HITCH (DRAWBAR "A" CAT. VERSION)	
L0302_0_4700	ATTACHMENT HITCH (DRAWBAR "EEC" TYPE APPROVED VERSION)	
A0101_1_63226	ENGINE (40 CV)	Power: 40 CV
A0102_1_63249	ENGINE (50 CV)	Power: 50 CV
A0301_1_63276	RADIATOR	
B0501_1_42781	DASHBOARD AND STEERING WHEEL	
B0602_0_63791	SEAT "GT60-M91"	
B0604_0_63758	SEAT (KAB P1)	
B0701_1_65937	SEAT CONNECTION	
C0202_2_64535	INTERMEDIATE SECTION	
C0302_1_72740	REAR AXLE	
D0202_2_72891	CLUTCH/INPUT SHAFT : STANDARD CLUTCH	
D0203_1_43188	CLUTCH/INPUT SHAFT : POWER TAKE-OFF WITH INDEPENDENT	
D0203_2_72897	CLUTCH/INPUT SHAFT : POWER TAKE-OFF WITH INDEPENDENT	
D0601_2_72925	INPUT SHAFT AND GEARS (SYNCHRONIZED REVERSER)	
D0701_2_72962	SECONDARY SHAFT GEARS	
D0801_1_72999	COUNTERSHAFT AND CORRESPONDING GEARS	
D0901_2_72753	CHANGE GEAR CONTROLS	
E0301_1_65025	REAR ELECTRICAL SYSTEM	
G0202_1_65175	HYDRAULIC SYSTEM	
M0101_1_65511	POSITION AND DRAFT CONTROL LIFT	
W0101_0_65465	WHEELS AND TYRES	

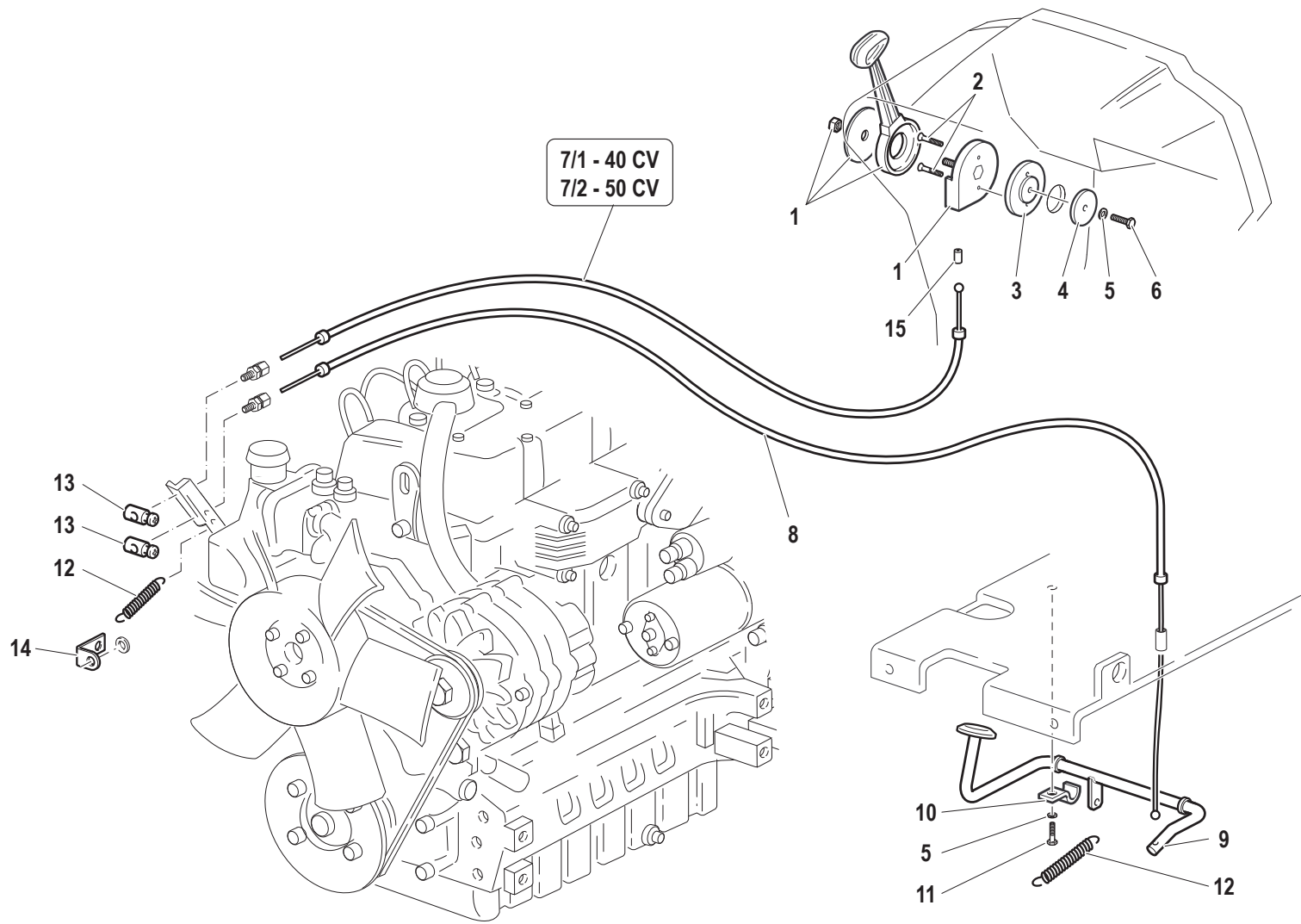

Pos.	Code	Q.ty	Description	Notes
1	F0828029070	0	ACCELERATOR	
2	31132562	0	SCREW TSVEI M6X16 UNI 5933	
3	56171877	0	FLANGE	
4	56171883	0	LOCK WASHER D.45x9/4	
5	F0843643060	0	WASHER 8	
6	31112150	0	SCREW TE M8X20 UNI 5739 8G	
7/1	58070489	0	CABLE	
7/2	58072074	0	CABLE	
8	58071375	0	CABLE	
9	59071769	0	ACCEL. PEDAL	
10	56071768	0	PLATE	
11	31112148	0	SCREW TE M8X18 UNI 5739 8G	
12	F0831125000	0	SPRING	
13	58048002	0	CLAMPING SCREW	
14	56173210	0	PLATE	
15	F0858520000	1	SLEEVE	

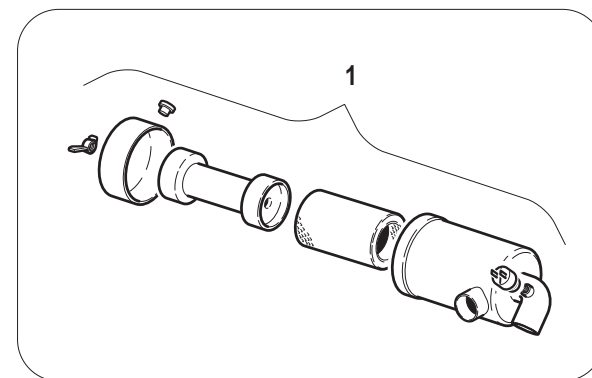
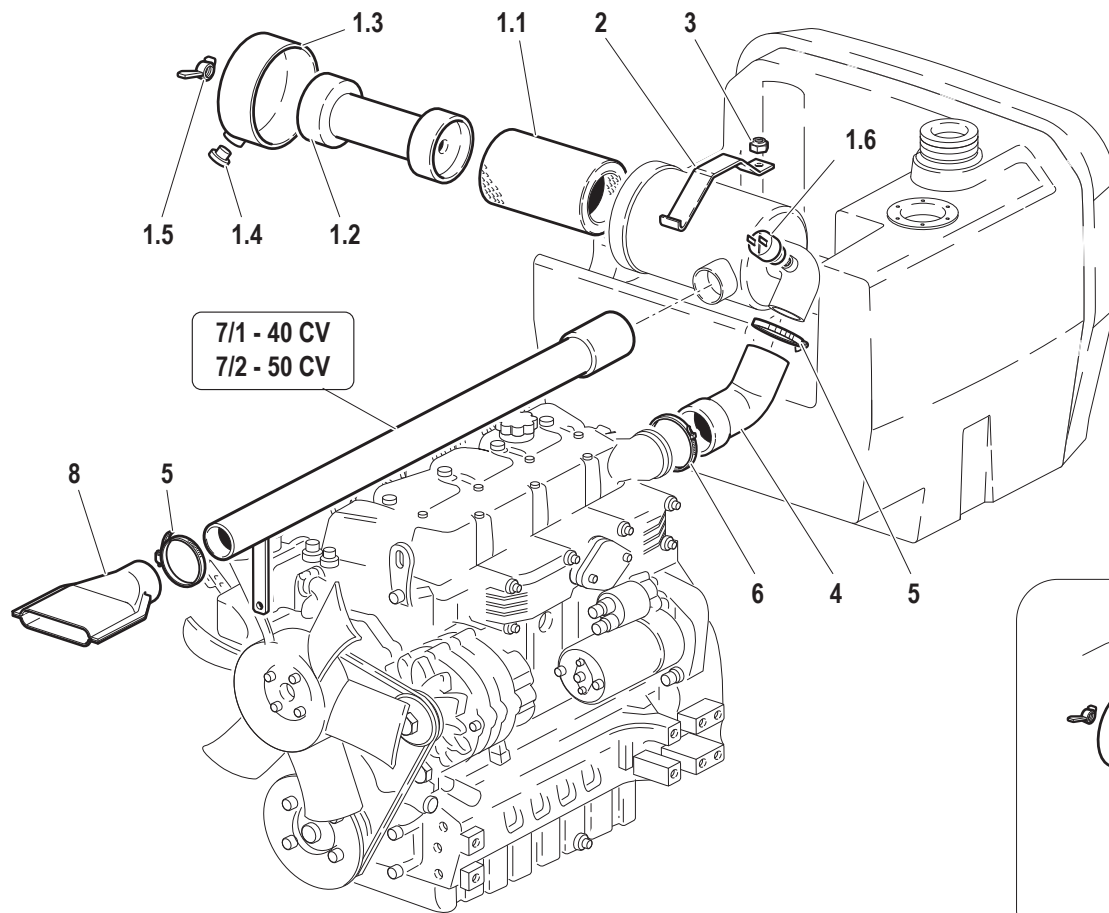

Pos.	Code	Q.ty	Description	Notes
1	58171749	0	AIR FILTER	
1.1	58172773	0	AIR FILTER CARTRIDGE	
1.2	59900144	0	FILTER INSERT	
1.3	59900145	0	COVER	
1.4	59900146	0	VALVE	
1.5	59900147	0	WINGNUT	
1.6	58171029	0	INDICATOR	
2	56171760	0	FIXING BRACKET	
3	F0814585000	0	SELFLOCK NUT M8	
4	55171751	0	SLEEVE	
5	F0817568000	0	CLAMP	
6	F0817568100	0	CLAMP	
7/1	59074279	0	PIPE	
7/2	59074308	0	PIPE	
8	57371825	0	SOCKET	

RS-M	RS-R	AR-M	AR-R
•	•	•	•

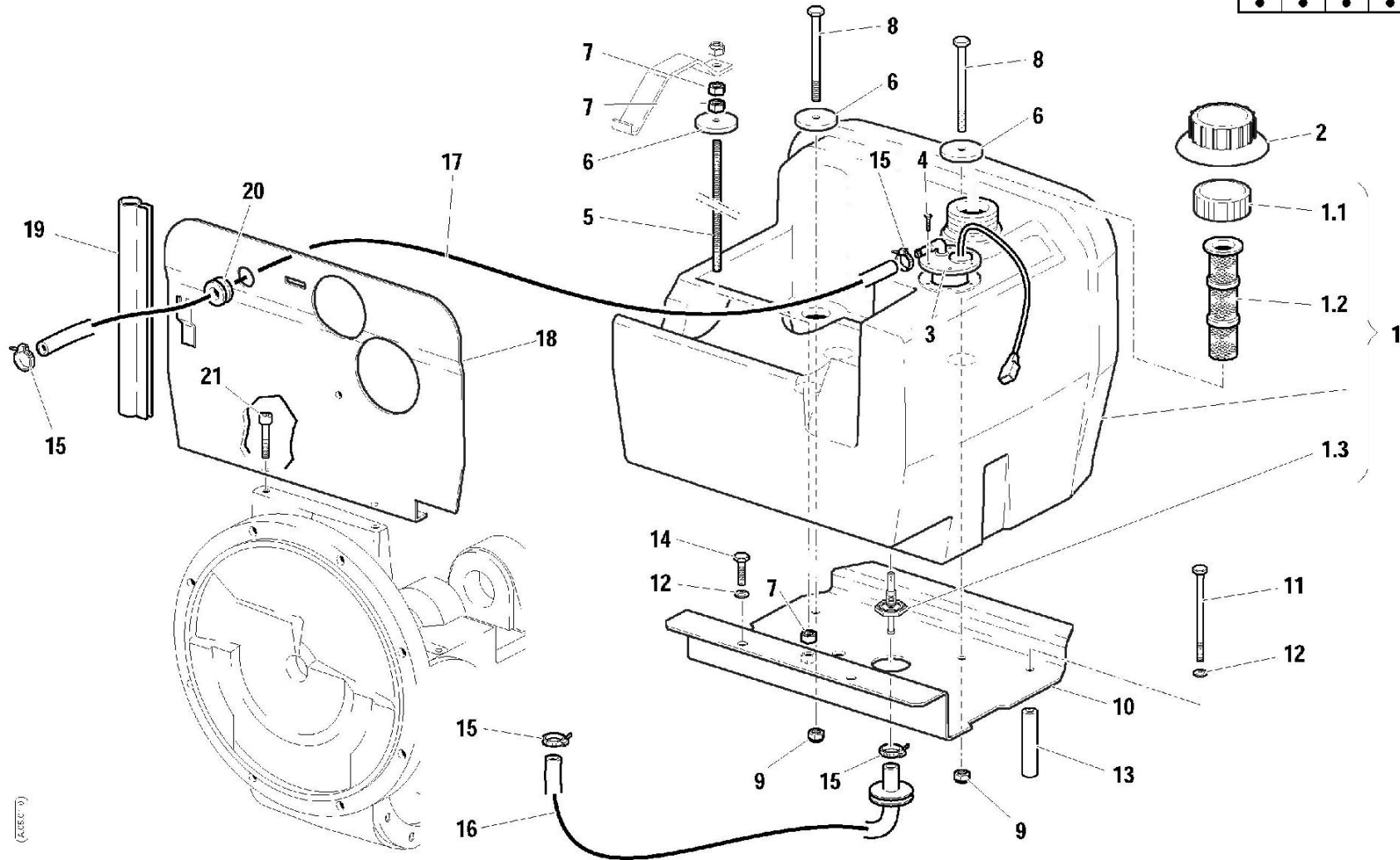

(A.B.C. 0)

Pos.	Code	Q.ty	Description	Notes
1	55274164	0	FUEL TANK	
1.1	F0849500001	0	TANK COVER	
1.2	F0849500002	0	FILTER	
1.3	57174884	0	PIPE FITTING	
2	57371900	0	LINING	
3	58170238	0	CONTROL	
4	F0861867050	0	SCREW M4,2X19 DIN 7981	
5	56170274	0	ROD	
6	56170275	0	SPACER	
7	F0814574000	0	NUT M8	
8	F0863097150	0	SCREW M8X190 UNI 5737	
9	31241080	0	SELFLOCK NUT M8	
10	59072491	0	TANK SUPPORT	
11	31112224	0	SCREW TE M10X130 UNI 5737	
12	F0843755000	0	WASHER 10	
13	56171775	0	SPACER	
14	31112210	0	SCREW TE M10X20 UNI 5739	
15	F0817512000	0	CLAMP	
16	58073237	0	PIPE	
17	58070690	0	PIPE	
18	56174307	0	GUARD	
19	58171212	0	GASKET	
20	58171901	0	CABLE GLAND 15,5-24-32-2	
21	F0862464050	0	SCREW UNI 5931	

1/1 - 40 CV - RS
 1/2 - 50 CV - RS
 1/3 - 40 CV - AR
 1/4 - 50 CV - AR

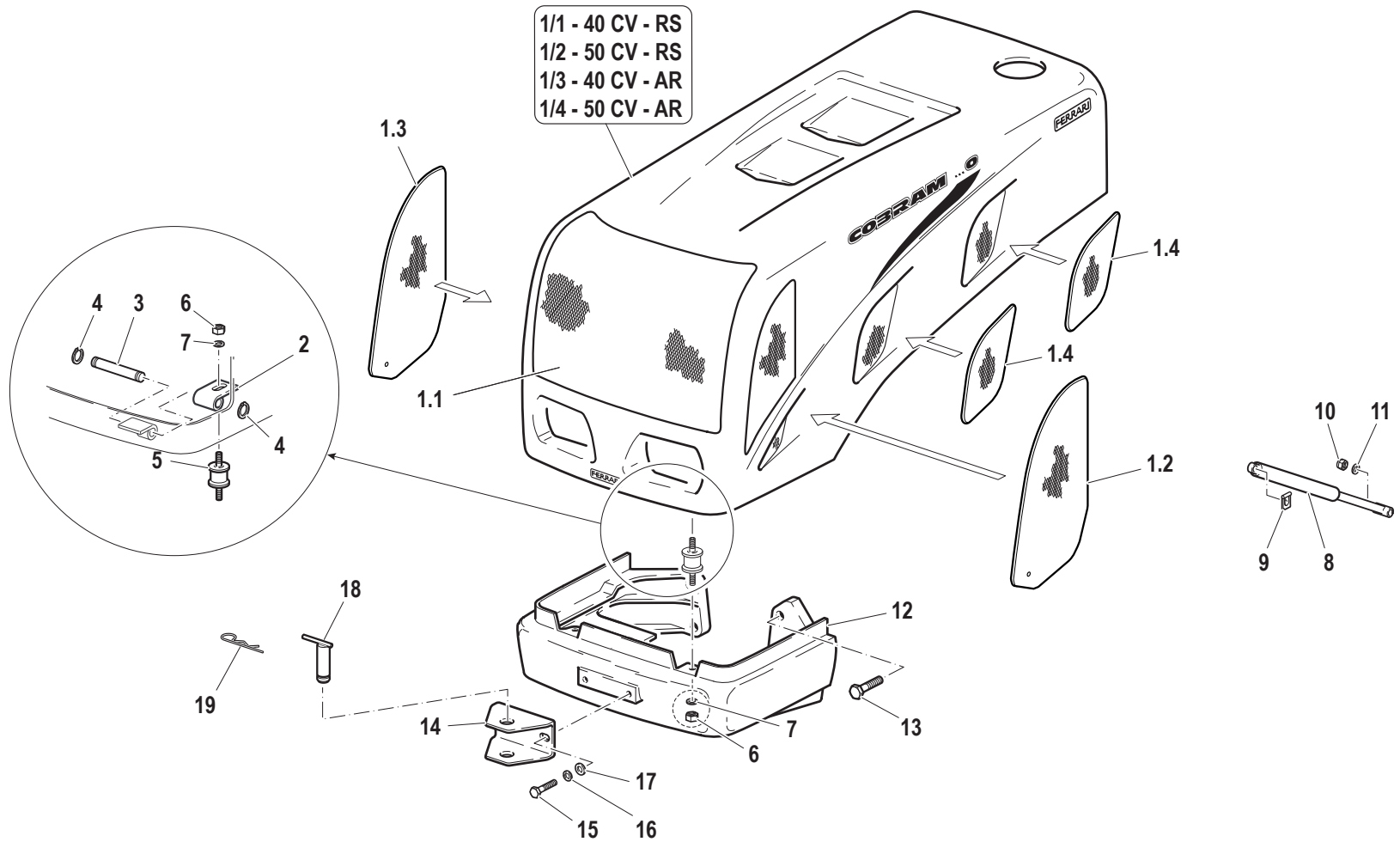

Pos.	Code	Q.ty	Description	Notes
1.1	56174424	0	FRONT GRILL	
1/1	59900248	0	COMPLETE HOOD	
1/2	59900249	0	COMPLETE HOOD	
1.2	56174426	0	FRONT GRILL	
1/3	59900250	0	COMPLETE HOOD	
1.3	56174425	0	FRONT GRILL	
1/4	59900251	0	COMPLETE HOOD	
1.4	56174427	0	FRONT GRILL	
2	56071684	0	BRACKET	
3	56071681	0	HINGE PIN	
4	35211060	0	SEEGER RING E 6 UNI 7434	
5	F0849211010	0	SILENT-BLOCK	
6	F0814629010	0	NUT M10	
7	F0843755000	0	WASHER 10	
8	58171868	0	SPRING	
9	58170436	0	CLIP	
10	F0814585000	0	SELFLOCK NUT M8	
11	31411084	0	WASHER 8,4x17	
12	51174228	0	FRONT SUPPORT	
13	F0864351050	0	SCREW M16X1,5X50UNI5738	
14	56174873	0	TOW HOOK	
15	31112328	0	SCREW TE M14X35 UNI 5739	
16	F0843921030	0	WASHER 14	
17	31411150	0	WASHER 15x28	
18	59075283	1	PIN	
19	F0851497000	1	SPLIT PIN	

◆
 VERSIONE CON CABINA
 VERSION WITH CAB
 VERSION AVEC LA CABINE
 VERSION MIT KABINE
 VERSIÓN CON LA CABINA

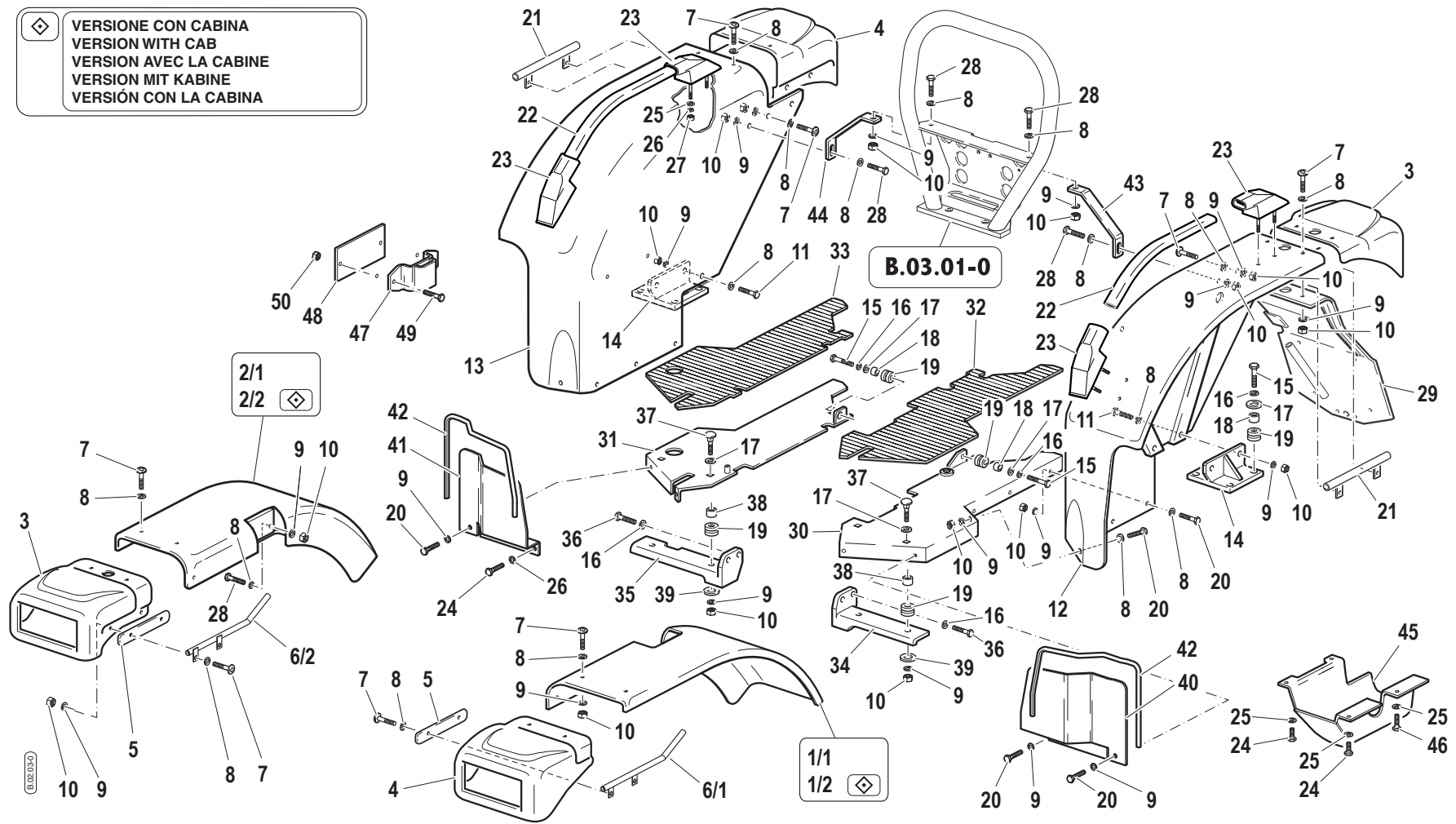

Pos.	Code	Q.ty	Description	Notes
1/1	59076428V	1	LEFT FRONT FENDER	
1/2	59077134V	1	LEFT FRONT FENDER	
2/1	59076432V	1	RIGHT FRONT FENDER	
2/2	59077135V	1	RIGHT FRONT FENDER	
3	57374133	0	SUPPORT	
4	57374134	0	SUPPORT	
5	56174135	0	FIXING BRACKET	
6/1	59076413	1	CABLE BARRIER RAIL	
6/2	59076414	1	CABLE BARRIER RAIL	
7	F0862479030	0	SCREW M8X20 7380	
8	31411084	0	WASHER 8,4x17	
9	F0843643060	0	WASHER 8	
10	F0814574000	0	NUT M8	
11	31112151	0	SCREW TE M8X25 UNI 5739 8G	
12	59074285V	1	LEFT REAR FENDER	
13	59074286V	1	RIGHT REAR FENDER	
14	59074248	0	FIXING BRACKET	
15	31112211	0	SCREW TE M10X30 UNI 5739	
16	F0843755000	0	WASHER 10	
17	F0843818000	0	WASHER 11x30/2,5	
18	56171954	0	SPACER	
19	55175174	1	BLOCK	
20	31111151	0	SCREW TE M8X16 UNI 5739 8G	
21	59074391	0	CABLE BARRIER RAIL	
22	56174337	0	MUDGUARD HANDLE	
23	55072935	0	SUPPORT	
24	31112082	0	SCREW TE M6X12 UNI 5739 8G	
25	31411066	0	WASHER 6,6x18	
26	F0843570000	0	WASHER 6	
27	31211060	0	NUT M6	
28	31112150	0	SCREW TE M8X20 UNI 5739 8G	
29	59075081	1	LICENCE PLATE HOLD	
30	59074262	0	PEDAL	
31	59074263	0	PEDAL	

SERIAL

MUD-GUARDS AND FLOOR BOARDS

CODE REV

B0203_0_2593

◆
 VERSIONE CON CABINA
 VERSION WITH CAB
 VERSION AVEC LA CABINE
 VERSION MIT KABINE
 VERSIÓN CON LA CABINA

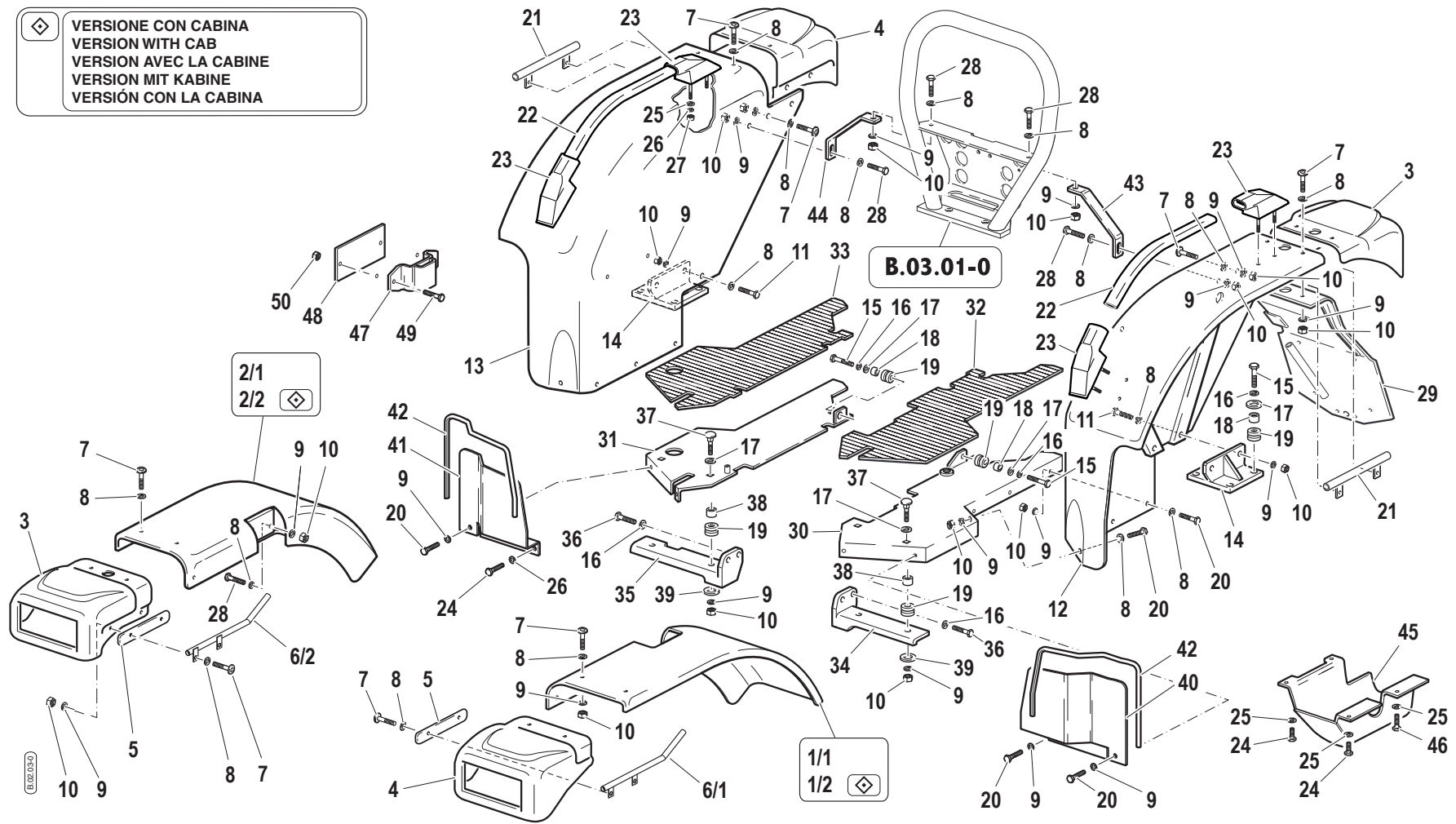

Pos.	Code	Q.ty	Description	Notes
32	57374338	0	FOOTREST COVER	
33	57374339	0	FOOTREST COVER	
34	59074326	0	LEFT FOOTBOARD SUPPORT	
35	59074327	0	RIGHT FOOTBOARD SUPPORT	
36	31112219	0	SCREW TE M10X25 UNI 5739	
37	31122804	0	SCREW TTQ M8X30 UNI 5731	
38	56171996	0	SPACER	
39	31411090	0	WASHER 9x24	
40	56174137	0	SHIELD	
41	56174136	0	SHIELD	
42	F0256808000	0	FLAT BAND	
43	56174366	0	BRACKET	
44	56174365	0	BRACKET	
45	59072471	0	SHIELD	
46	31112090	0	SCREW TE M6X16 UNI 5739 8G	
47	59070592	0	LEVER BEARING	
48	56172129	0	BRACKET FASTENER	
50	31241100	0	SELFLOCK NUT M10 6S	

◆ VERSIONE CON CABINA
 VERSION WITH CAB
 VERSION AVEC LA CABINE
 VERSION MIT KABINE
 VERSIÓN CON LA CABINA

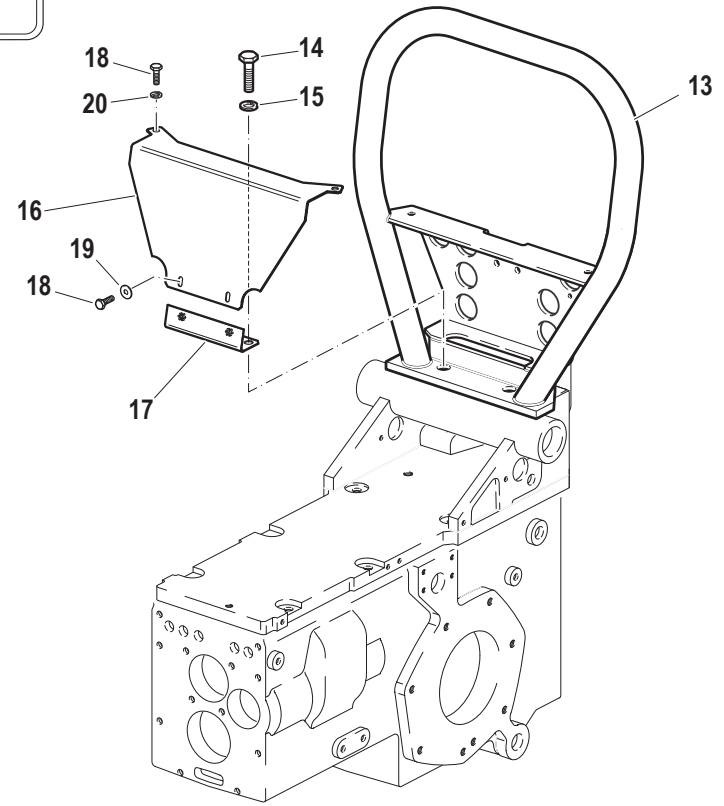
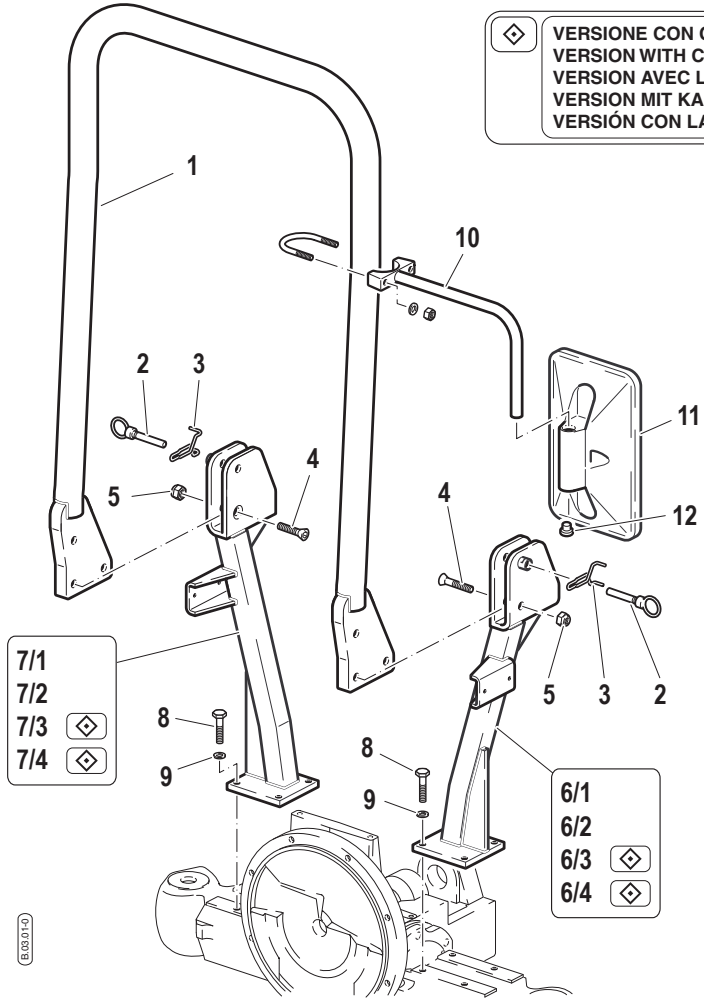

810311-0

Pos.	Code	Q.ty	Description	Notes
1	59071147	0	SAFETY ROLL BAR	
2	56171704	0	HINGE PIN	
3	58070097	0	SPRING	
4	F0864309100	0	SCREW M14X60 UNI 5933	
5	31241140	0	SELFLOCK NUT M14	
6/1	59071956	0	SUPPORT	
6/2	59072131	0	SUPPORT	
6/3	59076172	1	WING HOLDER	
6/4	59076181	1	WING HOLDER	
7/1	59071955	0	SUPPORT	
7/2	59072140	0	SUPPORT	
7/3	59076171	1	WING HOLDER	
7/4	59076182	1	WING HOLDER	
8	31112272	0	SCREW TE M12X30 UNI 5739	
9	F0843843060	0	WASHER 12	
10	59070591	0	SUPPORT	
11	30000514	0	REAR VIEW MIRROR	
12	58170968	0	PLUG	
13	59072114	0	SAFETY ROLL BAR	
14	31112264	0	SCREW TE M12X35 UNI 5739	
15	F0843843060	0	WASHER 12	
16	59075765	1	STRIKER PLATE	
17	59075766	1	LAMINATION	
18	31112082	1	SCREW TE M6X12 UNI 5739 8G	
19	31411064	1	WASHER 6,4x12,5	
20	F0843570000	1	WASHER 6	

1/1
COBRAM 40
1/2
COBRAM 50

FERRARI

TYPE DP09
EE APPR. N.: SV 2 e1 0012
MADE BY BCS S.p.A. ITALY

TYPE DP10
EE APPR. N.: SV 2 e1 0013
MADE BY BCS S.p.A. ITALY

6/1 - RS
6/2 - AR

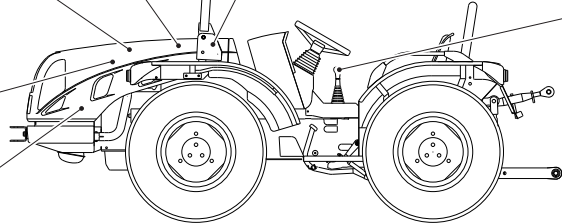
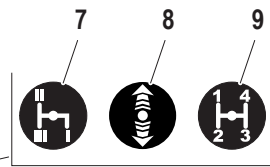

4/1 **RS**
4/2 **AR**

Made by BCS S.p.a. - Abbiadoro Italy
STABILIMENTO di LUZZARA (RE)

TIPO: _____

OMOLOGAZIONE NUMERO: _____

NUMERO DI IDENTIFIC.: _____

MASSA MAX. AMMISSIBILE KG: _____

MASSA MAX. ASSE ANTERIORE KG: _____

MASSA MAX. ASSE POSTERIORE KG: _____

MASSE MASSIME RIMORCHIABILI (KG)

SENZA FRENI	CON FRENI INDIPENDENTI
CON FRENI AD INERZIA	CON FREMAT. ASSISTITA

COEFF. DI ASSORBIMENTO

CONDOTTO (SECONDO DIRETTIVA CEE 77/937) m-1 ANNO



18/1- MONO
18/2- REV

15 - AR

ATTENZIONE - WARNING
ATTENTION - ACHTUNG
ATENCIÓN - ATENCAO

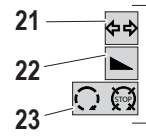

20

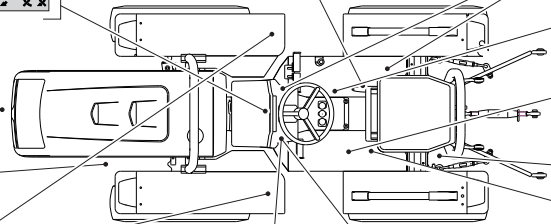

24

H

16 POS DRAFT

MEM 17

- SOLLEVATORE ELETTRONICO - VEDI TAVOLA...
- ELECTRONIC CONTROL LIFT- SEE TABLE...
- RÉLÈVEUR ÉLECTRONIQUE- VOIR TABLE...
- ELEKTRONISCHE HEBER - SIEHE TAFEL...
- ELEVADOR ELECTRONICO- MIRAR TABLA...

H.04.01-0

⊗

- NON PRESENTE CON FRIZIONE INDIPENDENTE
- MISSING WITH INDEPENDENT CLUTCH
- NE PAS PRÉSENT AVEC EMBRAYAGE INDEPENDANT
- FEHLEND MIT UNABHÄNGIGER KUPPLUNG
- AUSENTE CON EMBRAGUE INDEPENDIENTE

⊗ 19

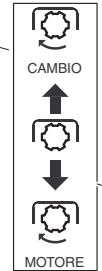

⊗ 12

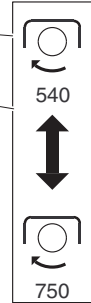

13

0.04.01.0

Pos.	Code	Q.ty	Description	Notes
1/1	58074380	0	DECAL	
1/2	58074381	0	DECAL	
2	58073549	0	DECAL	
3	58073548	0	DECAL	
4/1	58073553	0	DECAL	
4/2	58073552	0	DECAL	
5	58073554	0	DECAL	
6/1	58073646	0	PLATE	
6/2	58073647	0	PLATE	
7	58074223	0	DECAL	
8	58074220	0	DECAL	
9	58074222	0	DECAL	
10	58072737	0	PLATE	
11	F0808518050	0	RIVET 3,5x6,5	
12	58072573	0	PLATE	
13	58072575	0	PLATE	
14	F0854067050	0	PLATE	
15	58073156	0	PLATE	
16	58073018	0	PLATE	
17	58073019	0	PLATE	
18/1	F0907170114	0	TECHN. MANUAL COBRAM	
18/2	F0907170115	0	TECH. MANUAL COBRAM REVER	
19	58072520	0	INSTRUCTION PLATE	
20	58072510	1	INSTRUCTION PLATE	
21	58072509	1	INSTRUCTION PLATE	
22	58072517	1	INSTRUCTION PLATE	
23	58072511	1	INSTRUCTION PLATE	
24	58076077	1	DECAL	

RS-M	RS-R	AR-M	AR-R
		•	•

✘ - DIFFERENZIALE CON BLOCCAGGIO ELETTROIDRAUL.
- DIFFERENTIAL WITH ELECTROHYDRAULIC LOCKING
- DIFFERENTIEL AVEC BLOCAGE ÉLECTROHYDR.
- DIFFERENTIAL MIT ELEKTROHYDR. SPERRE
- DIFERENCIAL CON BLOQUEO ELECTROHIDRÁULICO

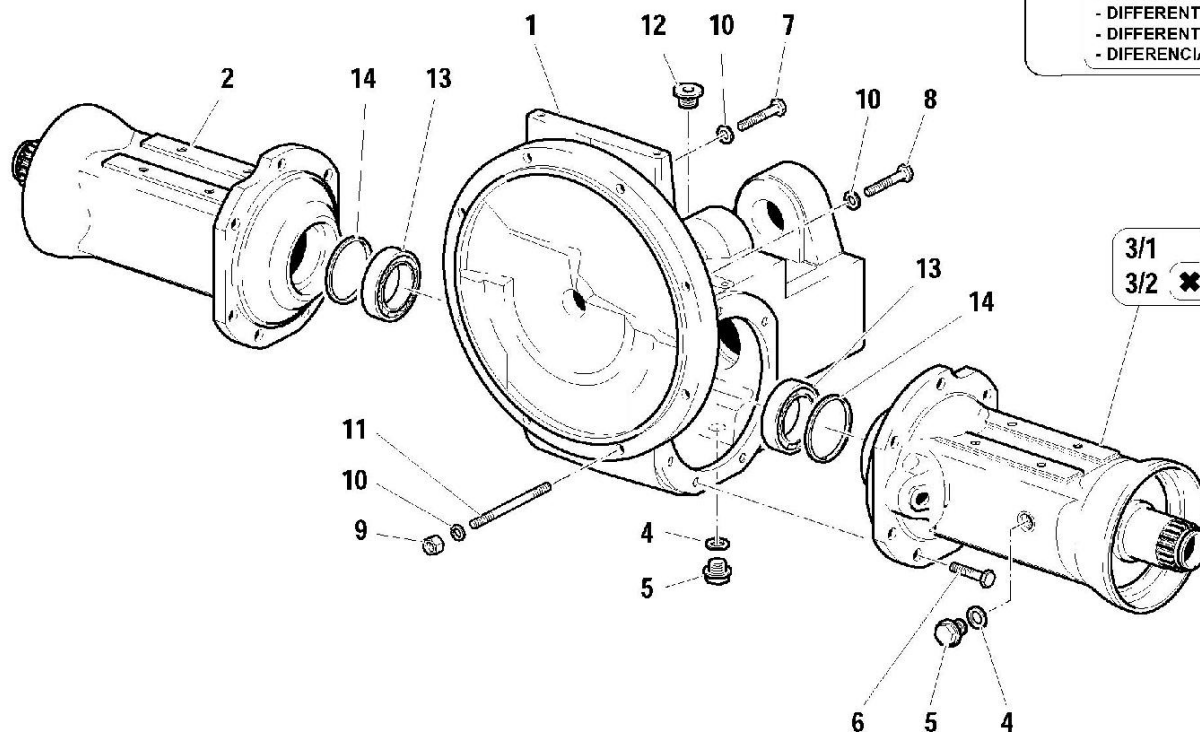

3/1
3/2 ✘

Pos.	Code	Q.ty	Description	Notes
1	51171614	0	FRONT AXLE HOUSING	
2	512A0909	1	FRONT AXLE HOUSING	
3/1	512A0908	1	FRONT AXLE HOUSING	
3/2	512A0910	1	FRONT AXLE HOUSING	
4	F0844273090	0	GASKET 22X28X1,5 CU 99,5	
5	58173495	0	PLUG	
6	31112264	0	SCREW TE M12X35 UNI 5739	
7	31112214	0	SCREW TE M10X45 UNI 5739	
8	31112211	0	SCREW TE M10X30 UNI 5739	
9	31211100	0	NUT M10	
10	F0843755000	0	WASHER 10	
11	F0838475000	0	STUD BOLT M10X90 UNI 5911 8.8	
12	58071790	0	PLUG	
13	F0812895000	0	BEARING 32008 (40X68X19)	
14	56371582	0	RING	
14	56371583	0	RING	
14	56371584	0	RING	
14	56371585	0	RING	
14	56371586	0	RING	



TRASMISSIONE ANTERIORE
 FRONT TRANSMISSION
 AVANT TRANSMISSION
 VORDERANTRIEB
 TRANSMISION DELANTERA

Tavola _____ Rev. _____
D.01.02 - **0** 11/2001

1/1

RS-M	RS-R	AR-M	AR-R
		•	•

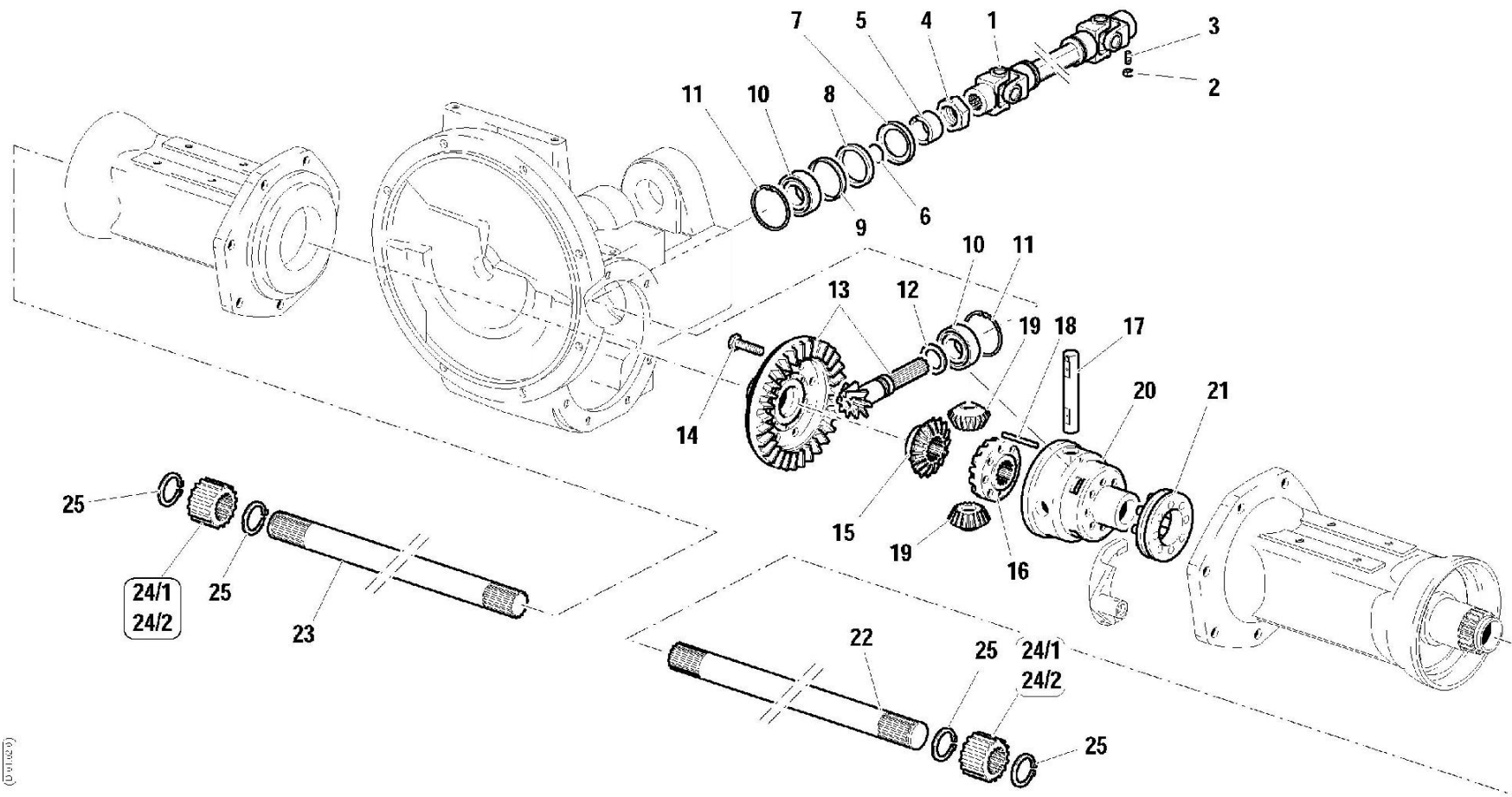

DIPINTO

Pos.	Code	Q.ty	Description	Notes
1	58171673	0	CONSTANT VEL. JOINT	
2	F0814574000	0	NUT M8	
3	F0862657000	0	GRAIN	
4	56371666	0	RING NUT	
5	56471665	0	SPACER	
6	38112670	0	O-RING	
7	56171671	0	PROTECTIVE RING D=62	
8	F0802190010	0	SEAL 42x62/7	
9	56171672	0	SPACER	
10	37221300	0	CYL. ROLLER BEARING	
11	35111063	0	SEEGER RING I 62 UNI 7438	
12	56371667	0	SHIM	
12	56371668	0	SHIM	
12	56371669	0	SHIM	
12	56371670	0	SHIM	
13	59371466	0	BEVEL GEAR	
14	F0863267050	0	SCREW M10x25	
15	52471513	0	CROWN WHEEL	
16	52471516	0	CROWN WHEEL	
17	56471508	0	PIN	
18	56371994	0	PIN	
19	52471509	0	PLANETARY GEAR	
20	51374866	0	HOUSING	
21	59071518	0	SLEEVE	
22	56572623	0	AXLE SHAFT	
23	56572624	0	AXLE SHAFT	
24/1	52471532	0	CROWN WHEEL	
24/2	52473922	0	CROWN WHEEL	
25	F0801175050	0	SEEGER RING E 24X1,75 UNI 7436	

RS-M	RS-R	AR-M	AR-R
•	•	•	•

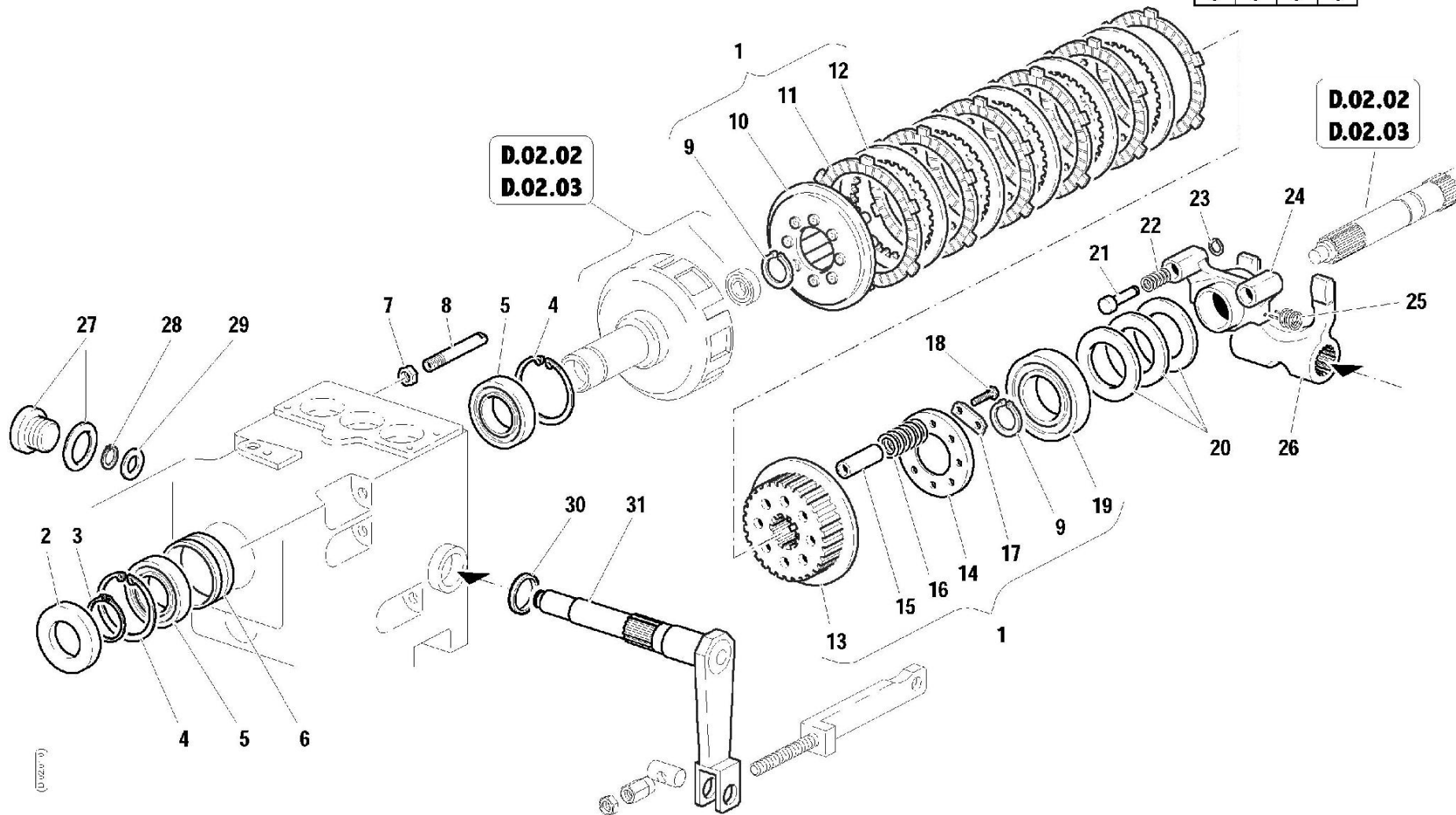

(D.02.01)

Pos.	Code	Q.ty	Description	Notes
1	59900224	0	CLUTCH KIT	
2	F0802187050	0	OIL SEAL 40x68/10	
3	35121040	0	SEEGER RING E 40 DIN 471	
4	F0801408000	0	SEEGER RING I 68 UNI 7437	
5	37111400	0	BEARING	
6	56171847	0	SPACER	
7	F0814689050	0	NUT M12X1,75 CH.17/H7	
8	56171934	0	PIPE	
9	F0801241010	0	SEEGER RING E 30 UNI 7436	
10	59271501	0	CLUTCH DISC	
11	58171558	0	CLUTCH DISC	
12	58171559	0	DISC	
13	52471502	0	DISC HUB	
14	56371551	0	FLANGE	
15	56171499	0	SPACER	
16	58071552	0	COUPLING SPRING	
17	52071702	0	CLAMPING PLATE	
18	31111091	0	SCREW E M6X14 UNI 5739 8G	
19	37111460	0	BEARING	
20	F0850104000	0	SHIM 54,8x47,2/0,2	
20	F0850104010	0	SHIM	
20	F0850104020	0	SHIM	
21	56471728	0	PISTON	
22	58071734	0	SPRING	
23	F0801028000	0	SEEGER RING E 8 UNI 7435	
24	51171842	0	SLEEVE	
25	F0819180080	0	SPRING	
26	52371733	0	CLUTCH FORK	
27	58071790	0	PLUG	
28	F0801094000	0	SEEGER RING E 14 UNI 7435	
29	52171744	0	SHIM	
30	38212503	0	OIL SEAL 25x35/7	
31	59271720	0	SHAFT	

SERIAL

FRIZIONE CLUTCH

CODE REV

D0201_0_3112

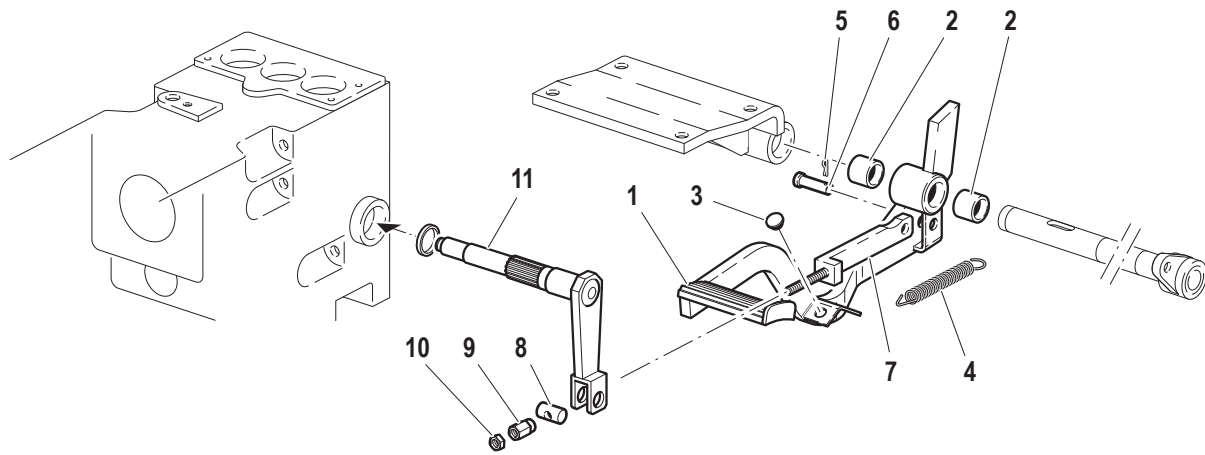

Pos.	Code	Q.ty	Description	Notes
1	59071752	1	CLUTCH PEDAL	
2	58171596	0	BUSHING	
3	F0822537050	0	BUFFER	
4	F0831139000	0	SPRING	
5	56471813	0	PIN	
6	F0810510000	0	SPLIT PIN A2,0X20 UNI 1336	
7	59071640	1	ROD	
8	56371714	1	PIN	
9	56371715	1	REGISTER	
10	F0814627000	1	NUT M10	

RS-M	RS-R	AR-M	AR-R
•	•	•	•

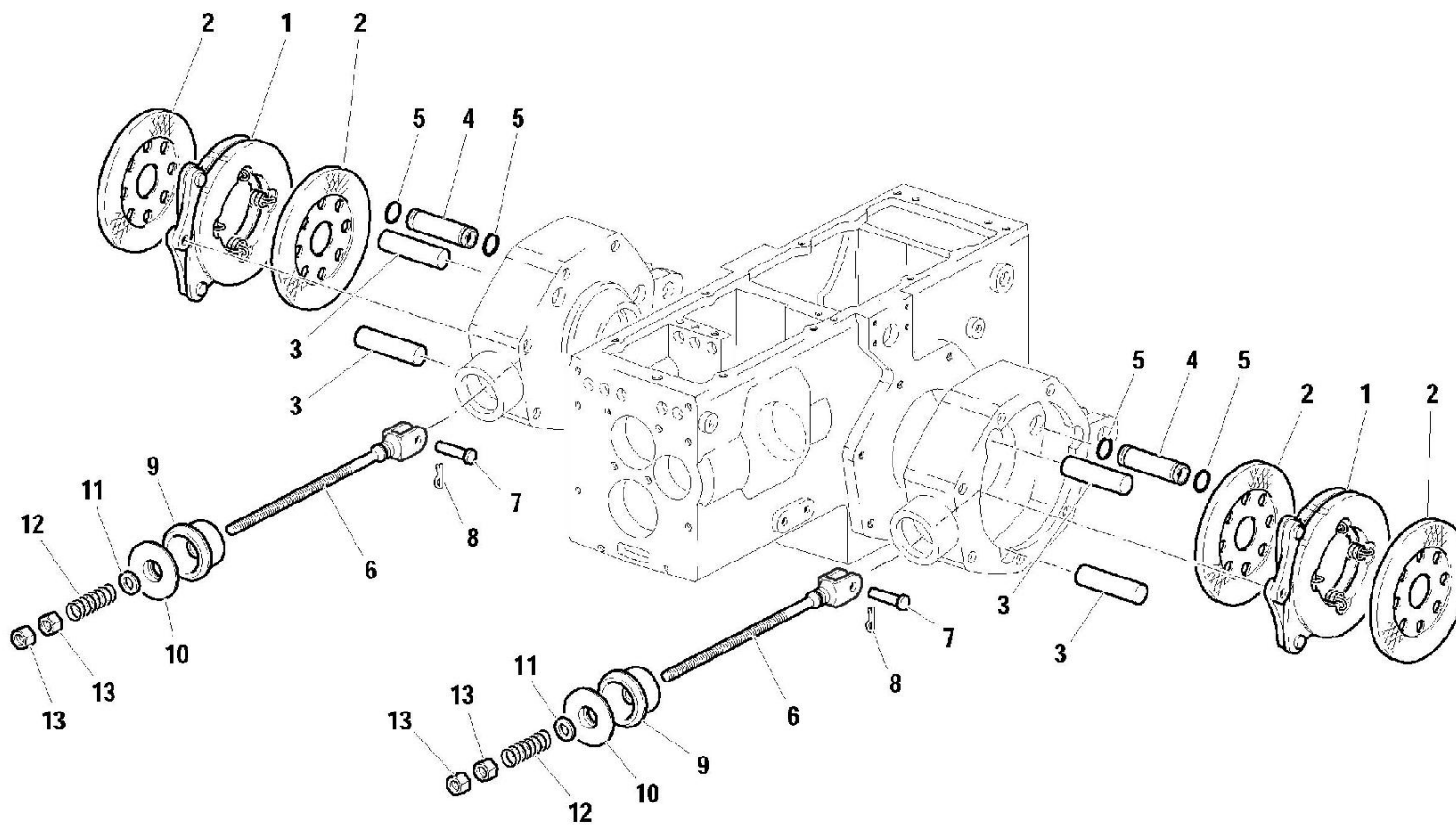

Pos.	Code	Q.ty	Description	Notes
1	58171706	0	BRAKE	
2	58171707	0	BRAKE DISC	
3	56371606	0	PIN	
4	56371605	0	PIN	
5	F0803186000	0	O-RING 123	
6	56371708	0	ROD	
7	56471709	0	PIN	
8	F0810510000	0	SPLIT PIN A2,0X20 UNI 1336	
9	55170047	0	BOOT	
10	56170043	0	COVER	
11	31411130	0	WASHER 13x24	
12	58070366	0	RETAINING SPRING	
13	F0814689020	0	NUT M12 UNI 5589 CL:8	

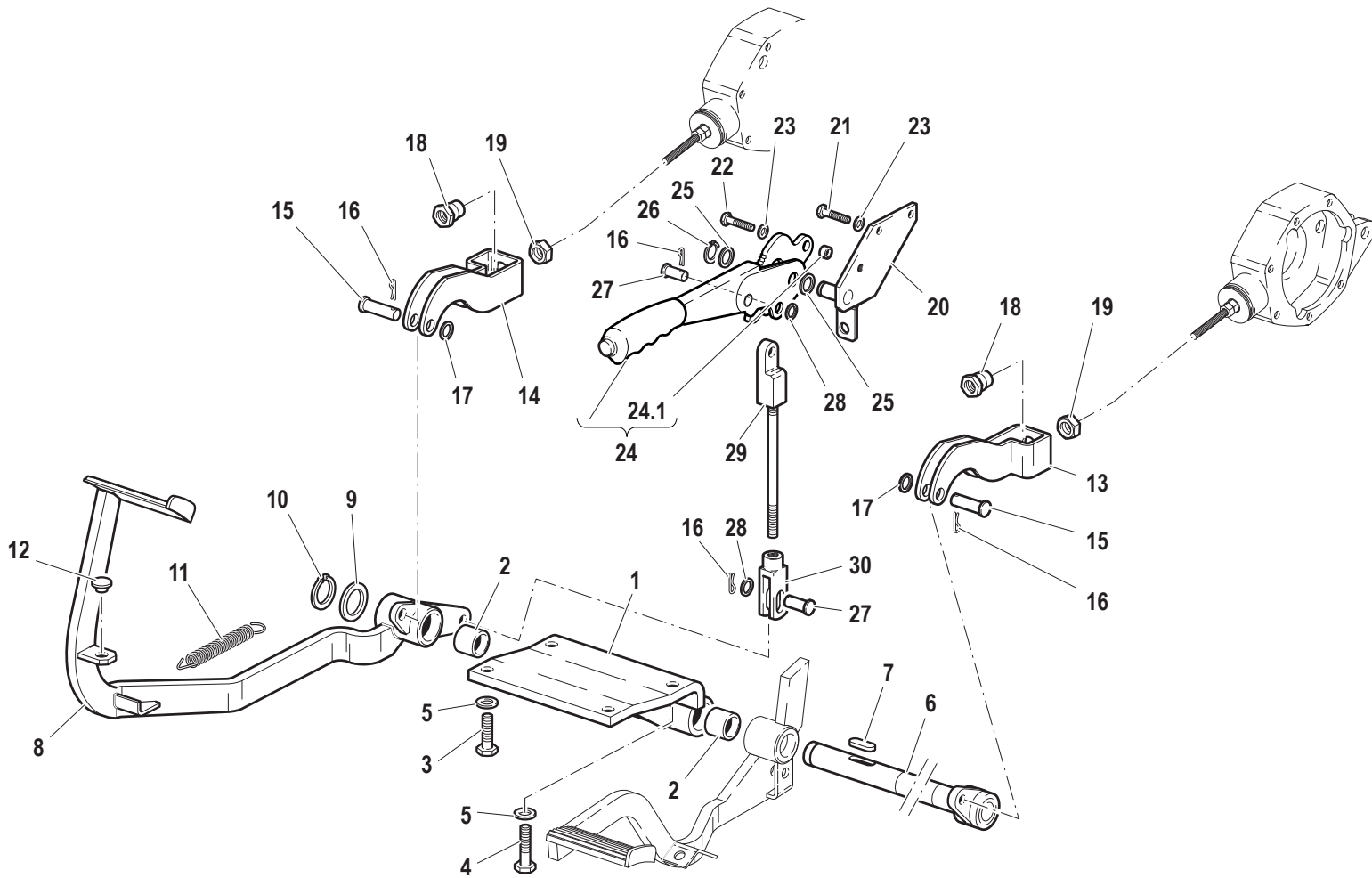

Pos.	Code	Q.ty	Description	Notes
1	59071724	0	SUPPORT	
2	58171596	0	BUSHING	
3	31112219	0	SCREW TE M10X25 UNI 5739	
4	31112211	0	SCREW TE M10X30 UNI 5739	
5	F0843755000	0	WASHER 10	
6	59072169	0	SHAFT	
7	F0806533000	0	KEY 8X7X30 UNI 6604/A	
8	59072167	0	BRAKE PEDAL	
9	56349629	1	RING	
10	35131026	0	SEEGER RING E 25X2 UNI 7436	
11	58070373	0	RESTORING SPRING	
12	F0822537050	0	BUFFER	
13	56172019	0	LEFT BRACKET	
14	56171787	0	BRACKET	
15	56470797	0	PIN	
16	F0810510000	0	SPLIT PIN A2,0X20 UNI 1336	
17	31411130	0	WASHER 13x24	
18	52373177	0	NUT	
19	F0814689020	0	NUT M12 UNI 5589 CL:8	
20	59075443	1	SUPPORT	
21	31112147	0	SCREW TE M8X18 UNI 5739 8G	
22	31112151	0	SCREW TE M8X25 UNI 5739 8G	
23	F0843643060	0	WASHER 8	
24	58178960	1	HANDBRAKE LEVER	
25	31411150	0	WASHER 15x28	
26	F0801095000	0	SEEGER RING E 14 7435	
27	56470365	0	PIN	
28	31411105	0	WASHER 10,5x21	
29	59075446	1	HANDBRAKE TIE-ROD	
30	50972173	0	FORK	
31	56171936	1	SPACER	

RS-M	RS-R	AR-M	AR-R
•	•	•	•

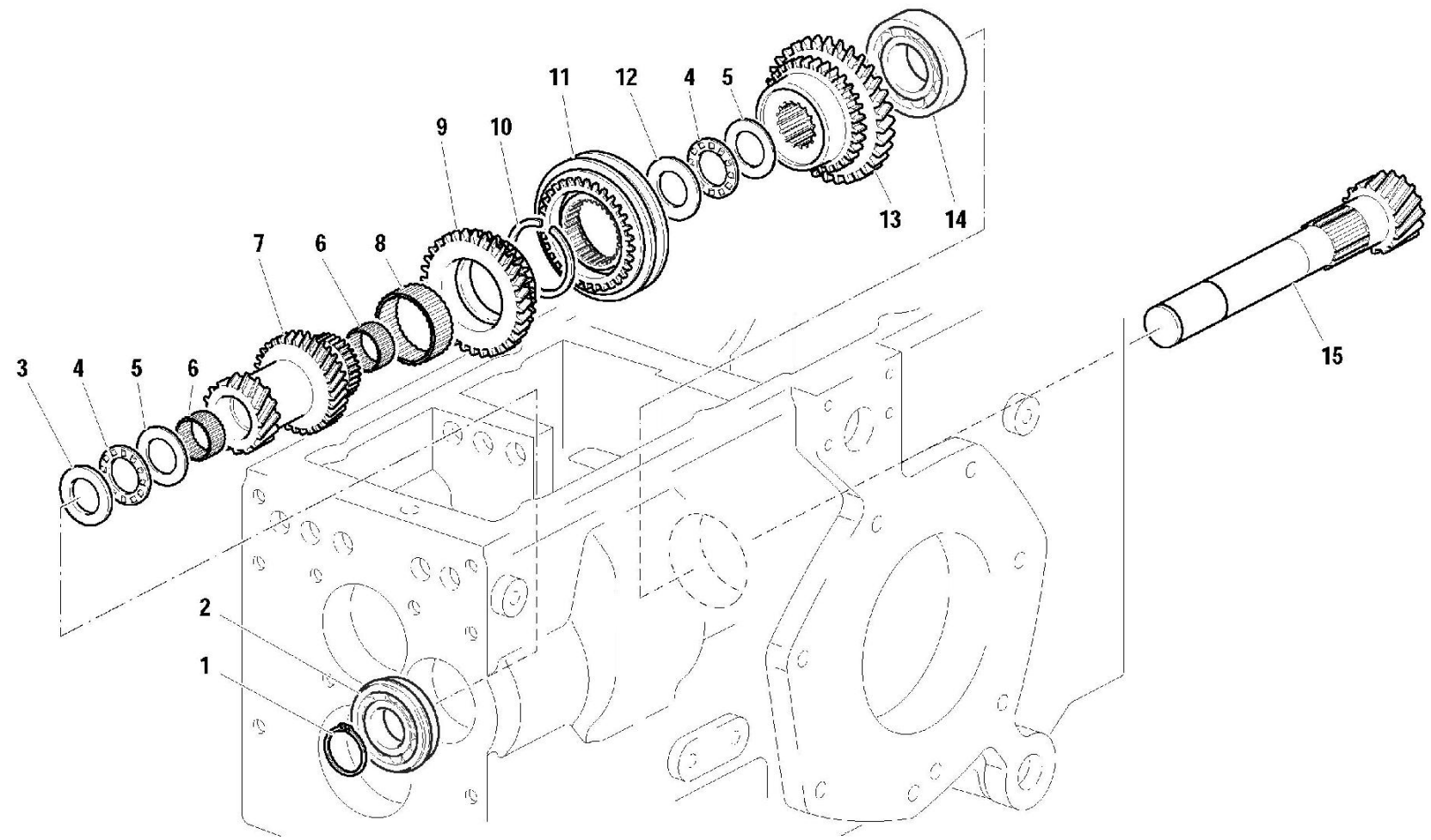

(D.08.01.01)

Pos.	Code	Q.ty	Description	Notes
1	35131026	0	SEEGER RING E 25X2 UNI 7436	
2	F0812709000	0	BEARING 6205-NR (25x52x15)	
3	52473815	0	THRUST PLATE	
3	52474239	0	THRUST PLATE	
3	52473791	0	THRUST PLATE	
4	58173790	0	BEARING	
5	58173792	0	THRUST PLATE	
6	F0812689000	0	ROLLER CAGE K 25X30/20 H	
7	52473713	0	GEAR	
8	F0812918050	0	ROLLER CAGE K 42X47/17	
9	52473719	0	GEAR	
10	58072505	0	SHOULDERED WASHER	
11	58172571	0	LOCK SYNCHRONIZER	
12	52473793	0	THRUST PLATE	
13	52473720	0	GEAR	
14	37111299	0	BEARING	
15	52473722	0	DRIVE SHAFT	

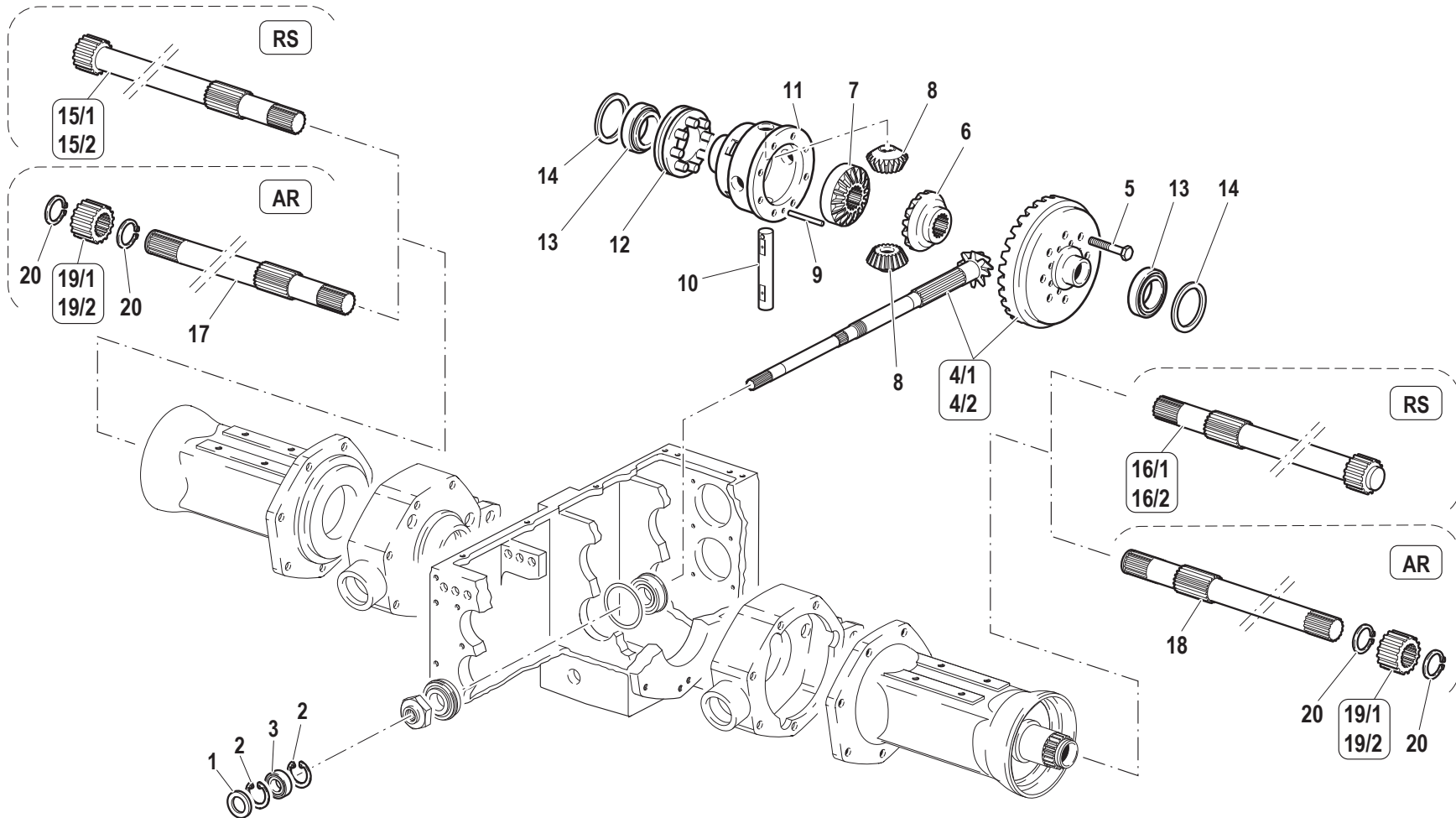

Pos.	Code	Q.ty	Description	Notes
1	38212003	0	OIL SEAL 20x42/7	
2	35111042	0	SEEGER RING I 42 DIN 472	
3	F0812631000	0	BEARING 6004 (20X42/12)	
4/1	59373783	1	BEVEL GEAR	
4/2	593A0890	1	BEVEL GEAR	
5	F0863267050	0	SCREW M10x25	
6	52471513	0	CROWN WHEEL	
7	52471516	0	CROWN WHEEL	
8	52471509	0	PLANETARY GEAR	
9	56371994	0	PIN	
10	56471508	0	PIN	
11	51374866	0	HOUSING	
12	59071518	0	SLEEVE	
13	F0812895000	0	BEARING 32008 (40X68X19)	
14	56371582	0	RING	
14	56371583	0	RING	
14	56371584	0	RING	
14	56371585	0	RING	
14	56371586	0	RING	
15/1	52471511	0	REAR AXLE SHAFT	
15/2	52473923	0	REAR AXLE SHAFT	
16/1	52471512	0	REAR AXLE SHAFT	
16/2	52473924	0	REAR AXLE SHAFT	
17	52572606	0	REAR AXLE SHAFT	
18	52572605	0	REAR AXLE SHAFT	
19/1	52471532	0	CROWN WHEEL	
19/2	52473922	0	CROWN WHEEL	
20	F0801175050	0	SEEGER RING E 24X1,75 UNI 7436	



RIDOTTORI LATERALI
 LATERAL REDUCTION GEARS
 REDUCTEURS LATÉRAUX
 SEITLICHE UNTERSETZER
 REDUCTORES LATERALES

Tavola _____ Rev. _____
D.11.02 - **0** 11/2001

1/1

RS-M	RS-R	AR-M	AR-R
		•	•

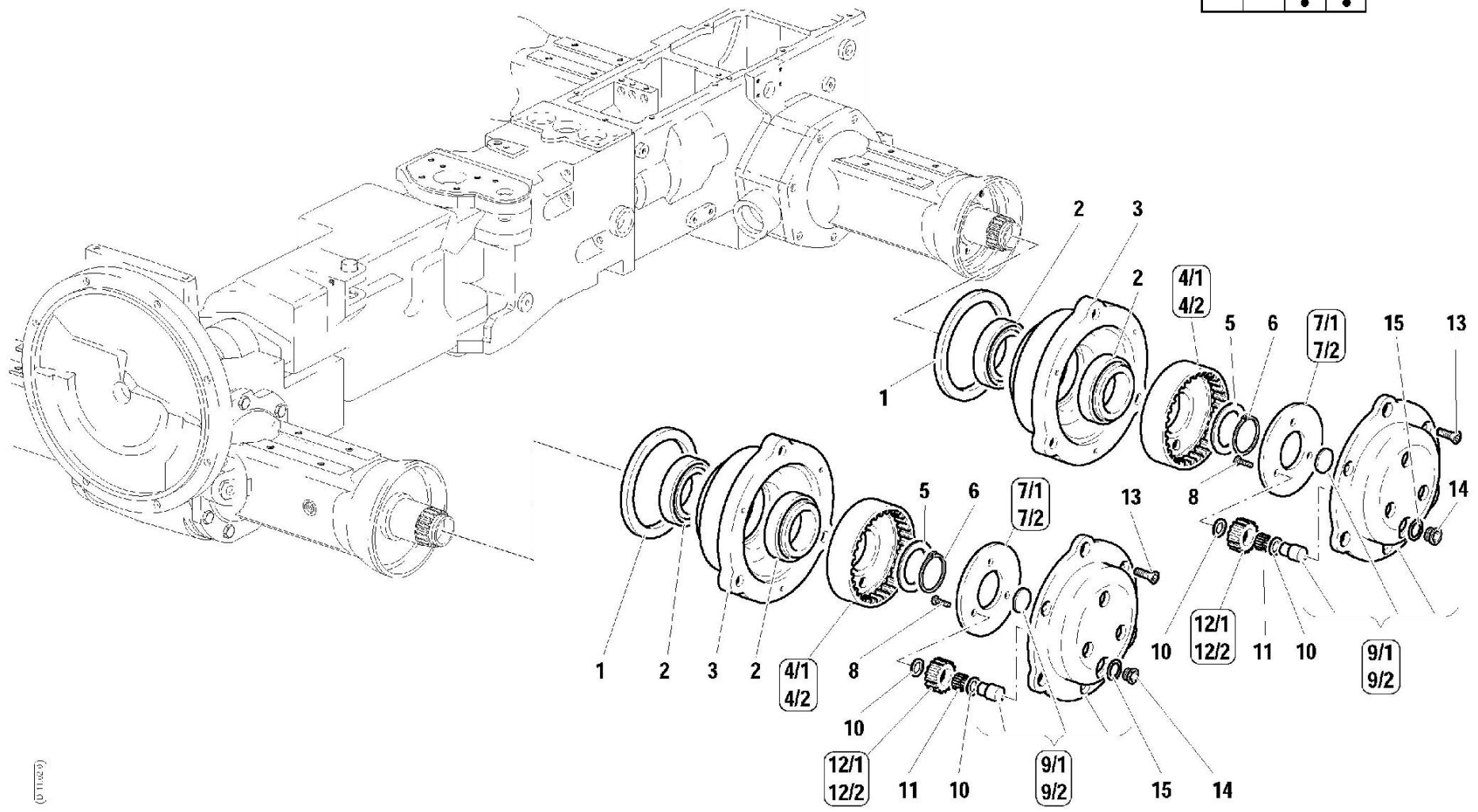

(D 11.02.01)

Pos.	Code	Q.ty	Description	Notes
1	F0802700150	0	SEAL 125x150x12	
2	F0812973000	0	BEARING 32011X	
3	51172508	0	HUB	
4/1	52471533	0	CROWN WHEEL	
4/2	52473920	0	CROWN WHEEL	
5	56371575	0	SHIM	
5	56371576	0	SHIM	
5	56371577	0	SHIM	
5	56371578	0	SHIM	
5	56371579	0	SHIM	
5	56373349	0	SHIM	
5	56373350	0	SHIM	
6	F0801346000	0	SEEGER RING E 48 UNI 7436	
7/1	56171568	0	ADJUSTING RING	
7/2	56173919	0	ADJUSTING RING	
8	F0862090000	0	SCREW M6X16 8.8	
9/1	59273878	0	COVER	
9/2	59273944	0	COVER	
10	58171567	0	SHIM	
11	58171653	0	ROLLER	
12/1	52471531	0	PLANETARY GEAR	
12/2	52473921	0	PLANETARY GEAR	
13	F0862655000	0	SCREW M8X25-5933	
14	56370081	0	PLUG	
15	F0844273090	0	GASKET 22X28X1,5 CU 99,5	

RS-M	RS-R	AR-M	AR-R
•		•	

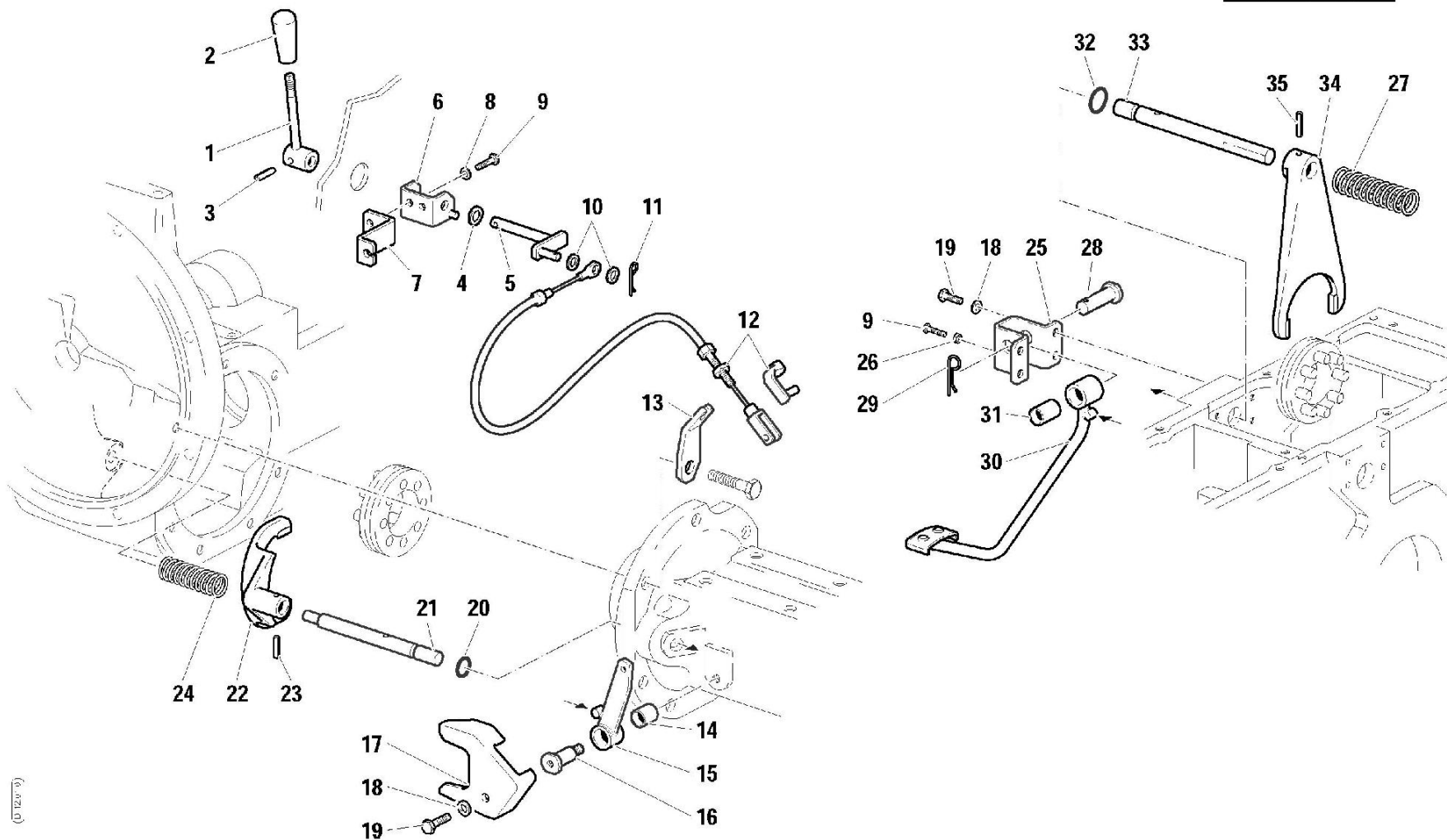

Pos.	Code	Q.ty	Description	Notes
1	59072008	0	LEVER	
2	P29533200000	0	GRIP	
3	34211030	0	ROLL PIN	
4	31411104	0	WASHER 10,5x18	
5	59072007	0	LOCKING BOLT	
6	59072006	0	BRACKET	
7	56172009	0	BRACKET	
8	F0843570000	0	WASHER 6	
9	31112093	0	SCREW TE M6X20 UNI 5739 8G	
10	31411064	0	WASHER 6,4x12,5	
11	F0810505010	0	SPLIT PIN A2,0X201336	
12	58172044	0	CABLE	
13	59071778	0	BRACKET	
14	F0804052000	1	BUSHING 18X14/17,8	
15	59071779	0	COMMAND LEVER	
16	56371777	0	HINGE PIN	
17	59071781	0	SHIELD	
18	F0843643060	0	WASHER 8	
19	31111151	0	SCREW TE M8X16 UNI 5739 8G	
20	38110913	0	O-RING 109 (9,13X2,62)	
21	56371616	0	LOCKING DEVICE	
22	51271615	0	FORK	
23	F0851260000	0	PIN 6X24 DIN 1481	
24	58070205	0	SPRING	
25	59071809	0	U BOLT	
26	F0814535050	0	NUT M6	
27	58070198	0	SPRING	
28	56371810	0	HINGE PIN	
29	F0810527000	0	SPLIT PIN A2,5X25 UNI 1336	
30	59071808	0	PEDAL	
31	F0804051000	0	BUSHING 18X14/24,8	
32	F0803178000	0	O-RING 117	
33	56371646	0	LOCKING DEVICE	
34	51271647	0	FORK	

SERIAL

DIFFERENTIAL GEAR LOCK

CODE REV

D1201_0_3551

RS-M	RS-R	AR-M	AR-R
•		•	

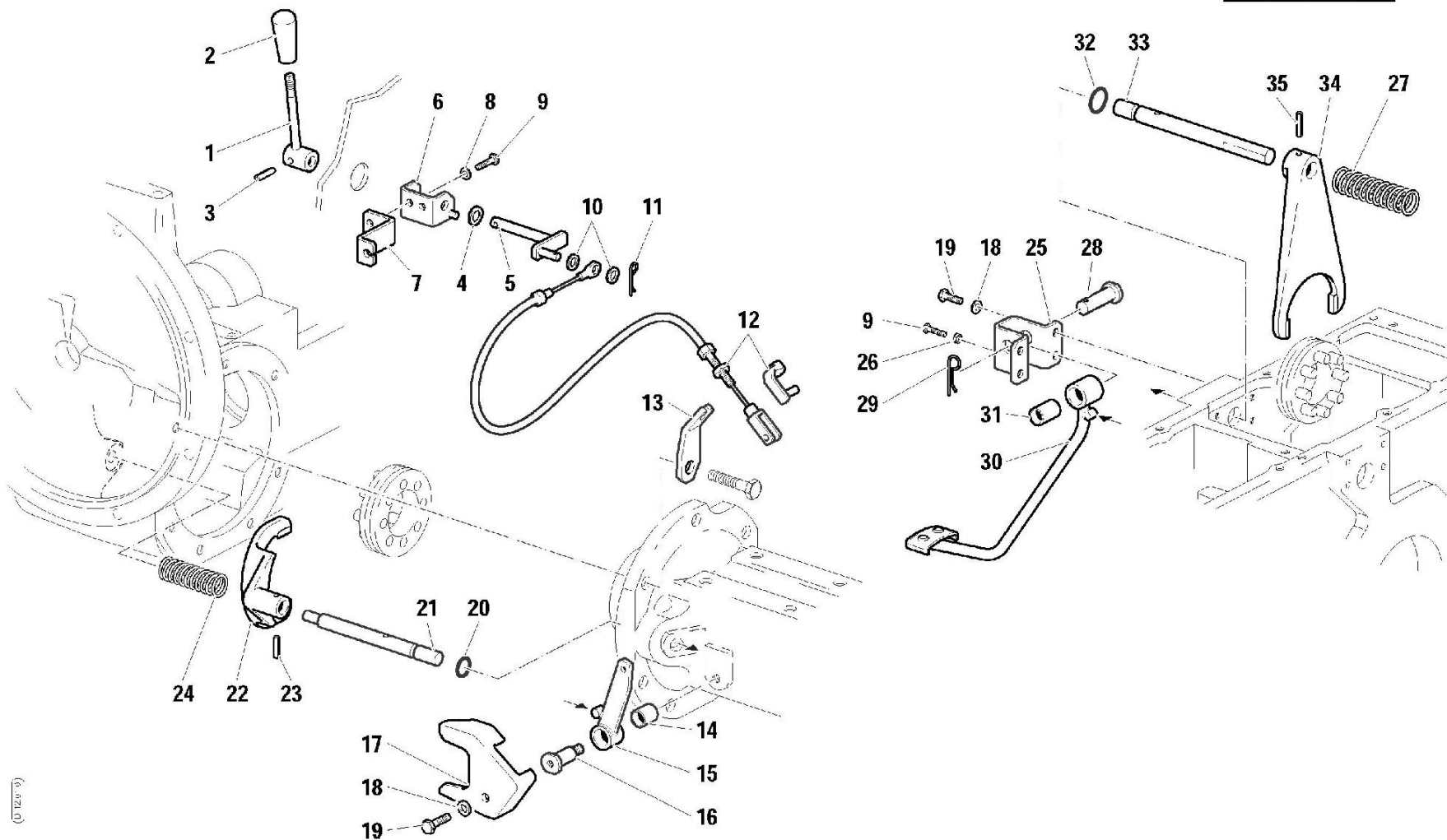

Pos.	Code	Q.ty	Description	Notes
35	F0851267050	0	PIN 6X30 DIN 7343 CL:C72	

RS-M	RS-R	AR-M	AR-R
•	•	•	•

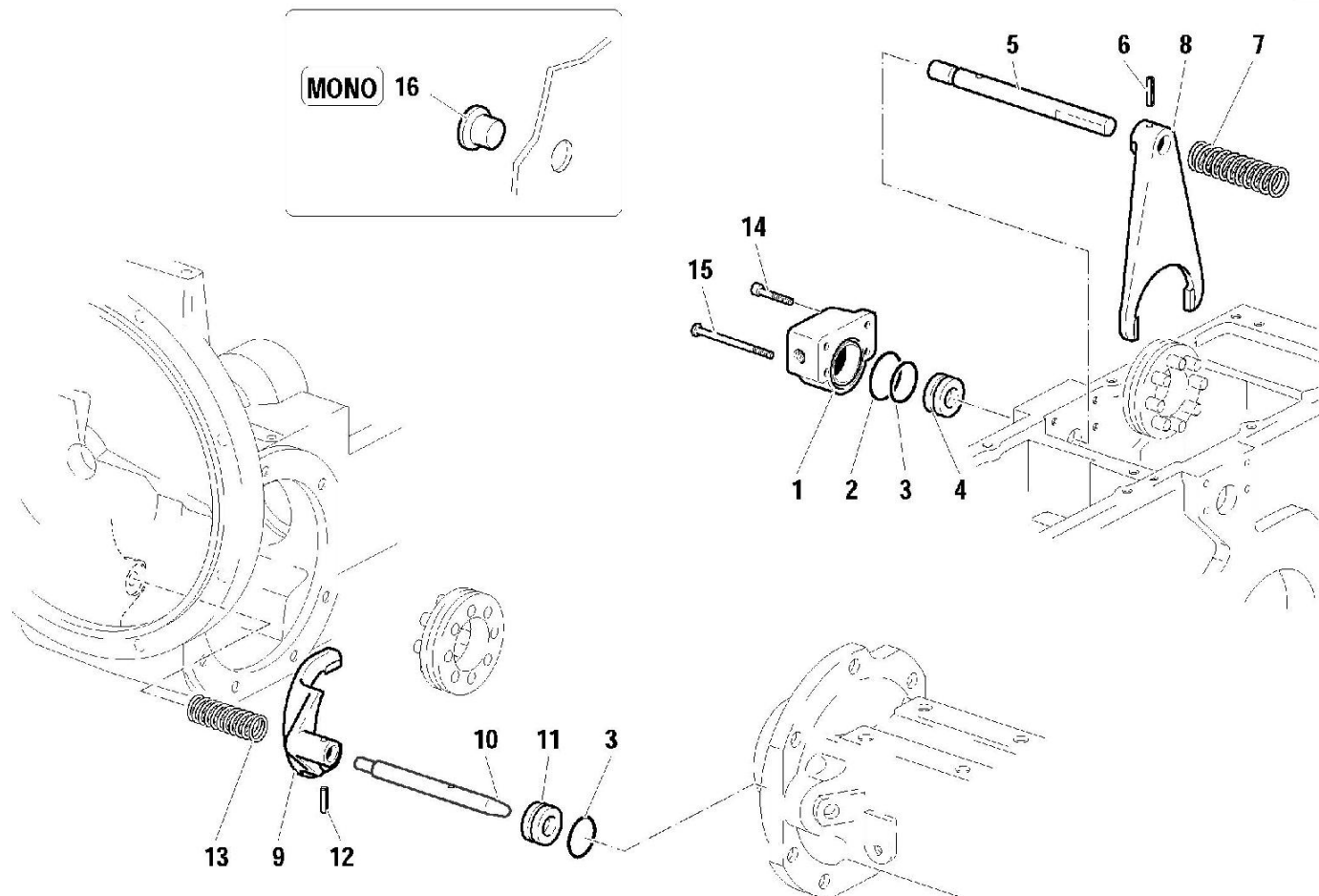

Pos.	Code	Q.ty	Description	Notes
1	52372343	0	SMALL BLOCK	
2	F0803209000	0	O-RING 3156	
3	58170195	0	GASKET	
4	56370187	0	PISTON	
5	56371646	0	LOCKING DEVICE	
6	F0851267050	0	PIN 6X30 DIN 7343 CL:C72	
7	58070198	0	SPRING	
8	51271647	0	FORK	
9	51271615	0	FORK	
10	56371613	0	LOCKING DEVICE	
11	56370583	0	PISTON	
12	F0851260000	0	PIN 6X24 DIN 1481	
13	58070205	0	SPRING	
14	31152085	0	SCREW TCEI M8X25 UNI 5931	
15	31112161	0	SCREW TE M8X50 UNI 5737 8G	
16	F0852516020	0	CABLE GLAND D.32	

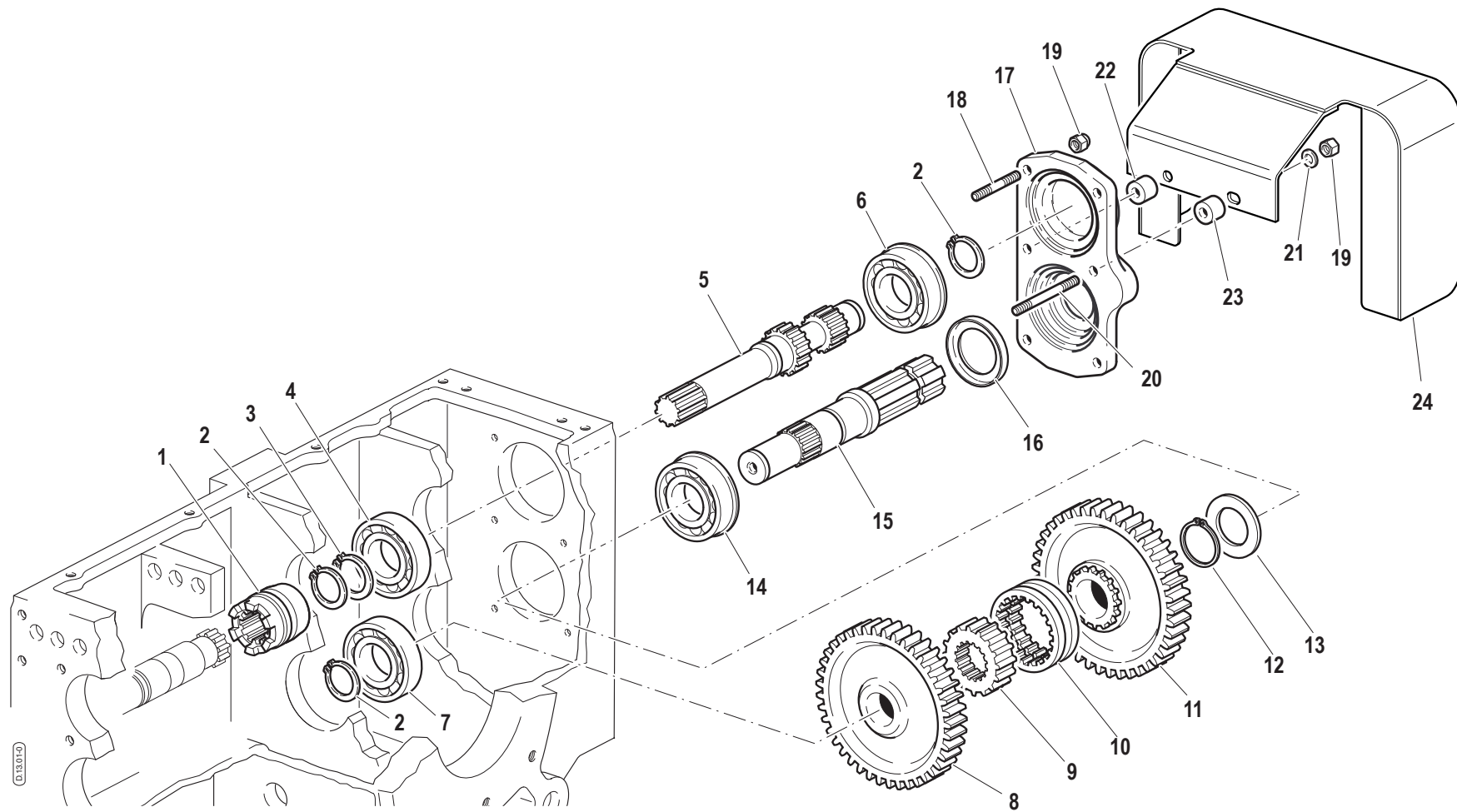

Pos.	Code	Q.ty	Description	Notes
1	52474190	0	GEAR SLEEVE	
2	35121030	0	SEEGER RING E 30 DIN 471	
3	35121035	0	SEEGER RING E 35 DIN 471	
4	37111353	0	BEARING	
5	52472494	0	SHAFT	
6	F0812779000	0	BEARING 6306-NR	
7	37111303	0	BEARING	
8	52471477	0	DRIVEN GEAR	
9	52471478	0	SLEEVE	
10	52471459	0	SLIDING SLEEVE	
11	52471476	0	DRIVEN GEAR	
12	F0801264050	0	SEEGER RING E 35X2,5 U/7436	
13	56470110	0	SHIM	
14	F0812849100	0	BEARING 6207-NR	
15	52471475	0	SHAFT	
16	F0802190010	0	SEAL 42x62/7	
17	51171648	0	COVER	
18	F0838131000	0	STUD BOLT M8X20 UNI 5911 8.8	
19	F0814574000	0	NUT M8	
20	F0838166018	0	STUD BOLT M8X45 UNI 5911 8.8	
21	F0843643060	0	WASHER 8	
22	56172080	0	SPACER	
23	56172079	0	SPACER	
24	560A0221	1	P.T.O. PROTECTION	

RS-M	RS-R	AR-M	AR-R
•		•	

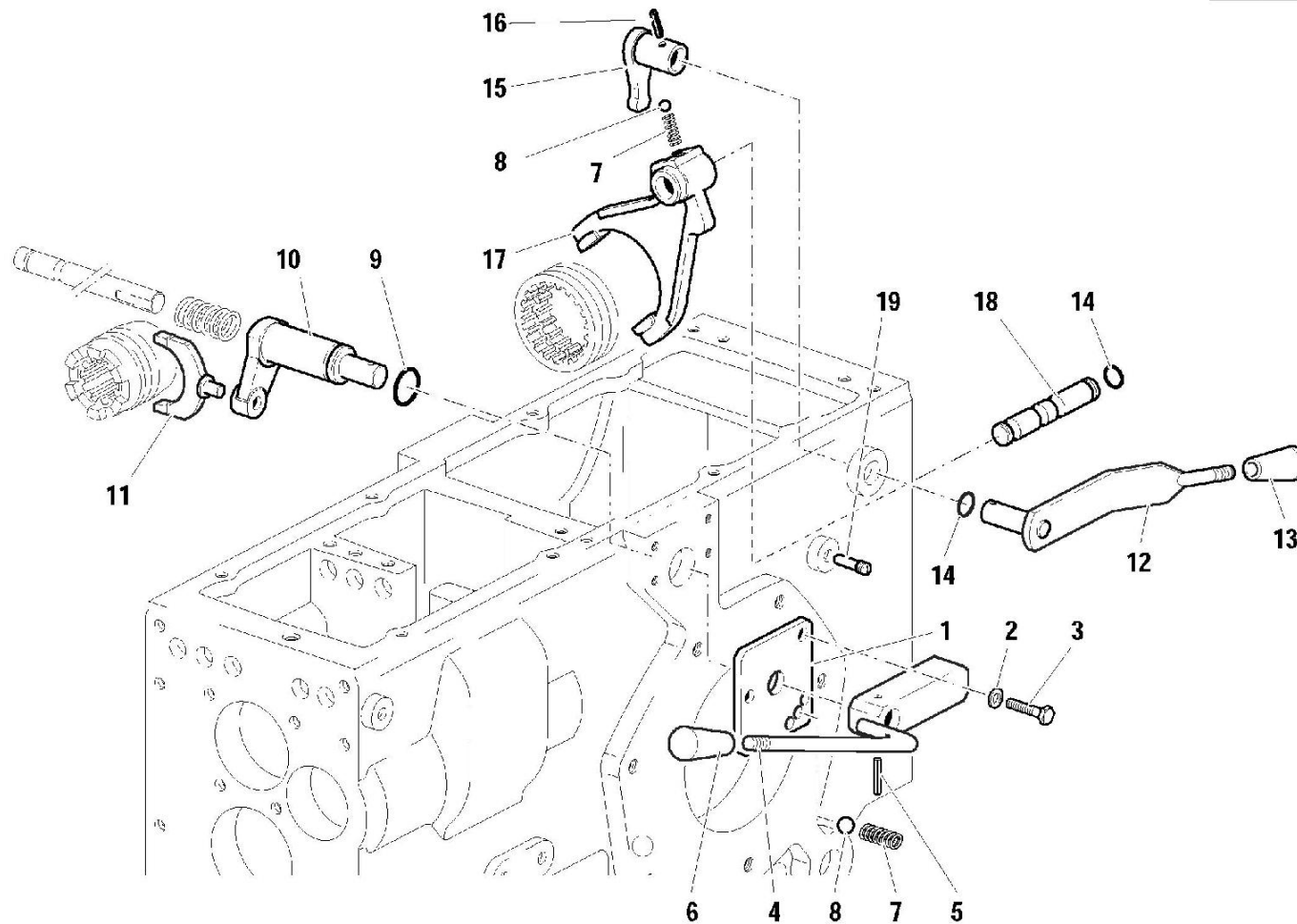

Pos.	Code	Q.ty	Description	Notes
1	59072754	0	PLATE	
2	F0843643060	0	WASHER 8	
3	31112150	0	SCREW TE M8X20 UNI 5739 8G	
4	59072761	0	LEVER	
5	34211054	0	ROLL PIN	
6	F0837534010	0	GRIP	
7	58070741	0	SPRING	
8	F0847434000	0	BALL	
9	38112200	0	O-RING 3087 (22,00X2,62)	
10	52371679	0	LEVER	
11	52472430	0	SELECTOR FORK	
12	59072752	0	LEVER	
13	F0837534060	0	GRIP	
14	38111191	0	O-RING 115 (11,91X2,62)	
15	59071676	0	LEVER	
16	F0851180000	0	PIN 5X26 DIN 1481 CL:C72	
17	51272353	0	FORK	
18	56371675	0	ROD	
19	56371678	0	SCREW	

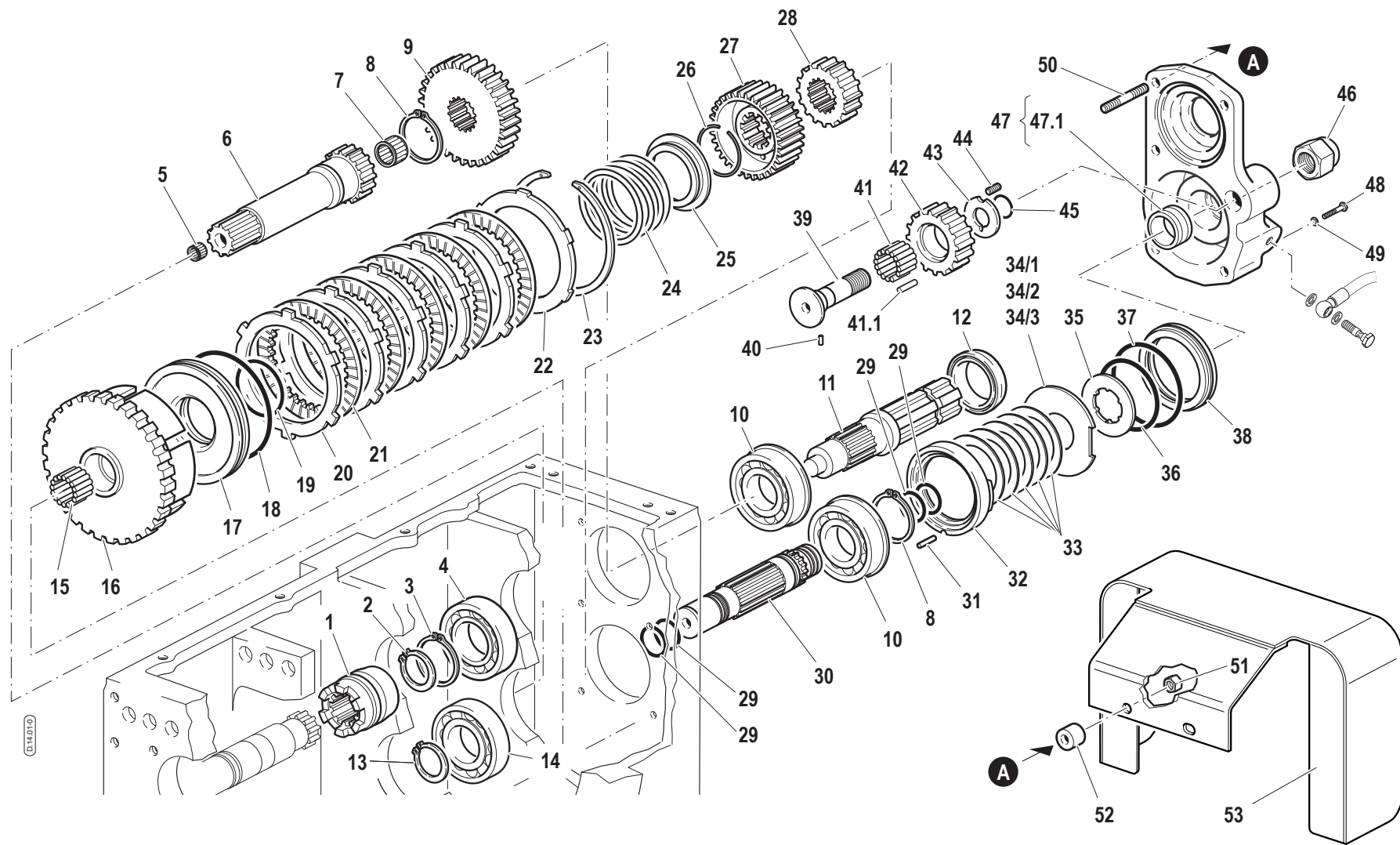

Pos.	Code	Q.ty	Description	Notes
1	52474190	0	GEAR SLEEVE	
2	35121030	0	SEEGER RING E 30 DIN 471	
3	35121035	0	SEEGER RING E 35 DIN 471	
4	37111353	0	BEARING	
5	F0812525100	0	BUSHING HK1210-B	
6	52472272	0	CONTROL SHAFT	
7	F0812599090	0	ROLLER CAGE K 18x24/20	
8	F0801264050	0	SEEGER RING E 35X2,5 U/7436	
9	52472325	0	DRIVEN GEAR	
10	F0812849100	0	BEARING 6207-NR	
11	52472273	0	SHAFT	
12	F0802190010	0	SEAL 42x62/7	
13	F0801241010	0	SEEGER RING E 30 UNI 7436	
14	37111303	0	BEARING	
15	F0812736010	0	ROLLER CAGE K 30X35/20 H	
16	59272426	0	CLUTCH HOUSING	
17	53272293	0	PISTON	
18	58172400	0	GASKET	
19	58172402	0	GASKET	
20	58172447	0	DISC	
21	58172448	0	DISC	
22	52372292	0	RING	
23	58072389	0	CIRCLIP	
24	58074092	0	RESTORING SPRING	
25	56372282	0	RING	
26	58072399	0	SAFETY RING	
27	52472342	0	DISC HUB	
28	52472322	0	DRIVEN GEAR	
29	58072398	0	SEAL	
30	59275946	1	SHAFT	
31	F0851226000	0	PIN 6X12 UNI 1707 CL:C20	
32	56472368	0	SPACER	
33	58072382	0	CUP SPRING	
34/1	56472374	0	BRAKE DISC	

SERIAL

POWER TAKE-OFF WITH INDEPENDENT CLUTCH

CODE REV

D1401_0_3649

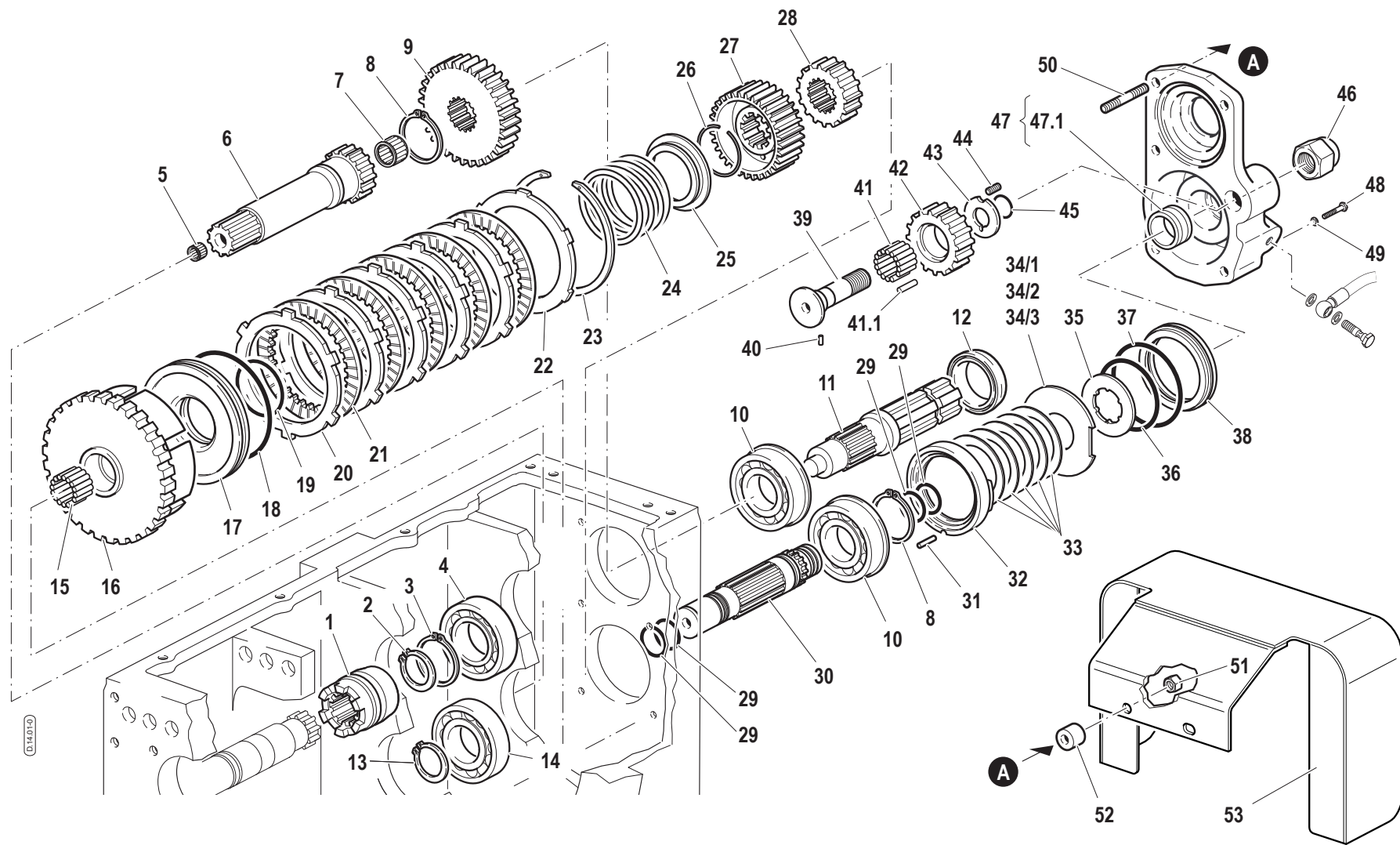

Pos.	Code	Q.ty	Description	Notes
34/2	56472375	0	BRAKE DISC	
34/3	56472376	0	BRAKE DISC	
35	56472383	0	BRAKE DISC	
36	38116317	0	RING	
37	F0803286045	0	O-RING 4300	
38	53273000	0	PISTON	
39	52473001	0	GEAR PIN	
40	F0851018000	0	CYLINDRICAL PLUG 3X6 UNI 1707	
41	58172350	0	ROLLER BEARING	
41.1	58172351	0	ROLLER	
42	52472324	0	PTO GEAR	
43	56472390	0	SHIM	
44	F0862473050	0	GRAIN	
45	F0803186000	0	O-RING 123	
46	F0814797000	0	SELFLOCK NUT M16X1,5	
47	59272425	0	COVER	
47.1	56472377	1	BUSHING	
48	F0862448100	0	SCREW M8X10 UNI 5740	
49	F0843641000	0	COPPER WASHER 8x14/1,5	
50	F0838166018	0	STUD BOLT M8X45 UNI 5911 8.8	
51	F0814574000	0	NUT M8	
52	56172080	0	SPACER	
53	560A0221	1	P.T.O. PROTECTION	



COMANDI PRESA DI FORZA - FRIZIONE INDIPENDENTE
 INDEPENDENT CLUTCH - POWER TAKE-OFF CONTROLS
 COMMANDES PRISE DE FORCE - EMBRAYAGE INDEPENDANT
 UNABHÄNGIGE KUPPLUNG - ZAPFWELLE STEUERUNGEN
 MANDOS TOMA DE FUERZA - EMBRAGUE INDEPENDIENTE

Tavola **D.14.02** Rev. **0** 11/2001

1/1

RS-M	RS-R	AR-M	AR-R
•	•	•	•

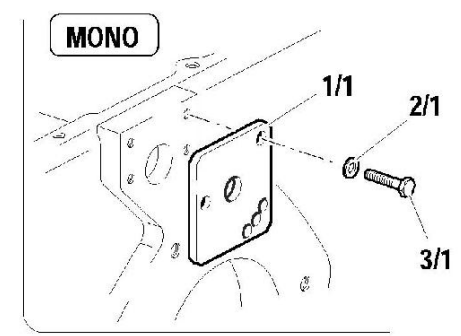
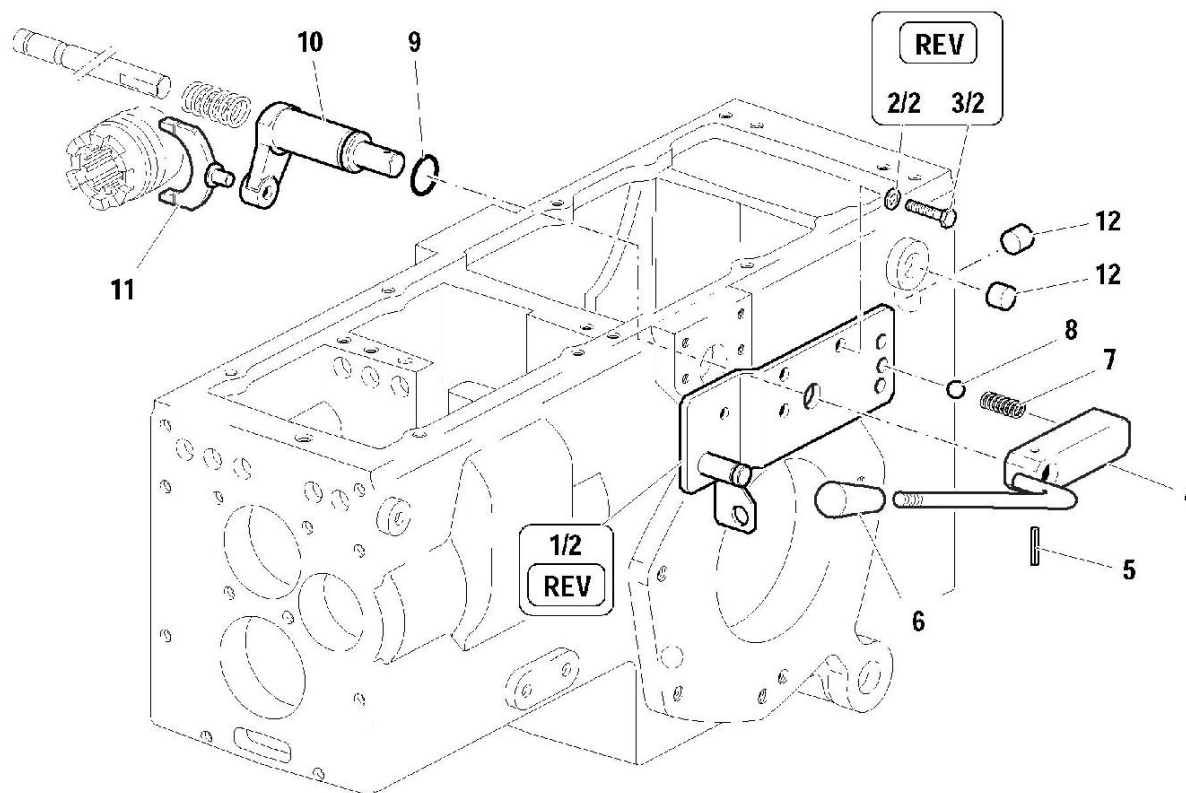

D.14.02/01

Pos.	Code	Q.ty	Description	Notes
1/1	59072754	0	PLATE	
1/2	59072753	0	PLATE	
2/1	F0843643060	0	WASHER 8	
2/2	F0843643060	0	WASHER 8	
3/1	31112150	0	SCREW TE M8X20 UNI 5739 8G	
3/2	31112147	0	SCREW TE M8X18 UNI 5739 8G	
4	59072761	0	LEVER	
5	34211054	0	ROLL PIN	
6	F0837534010	0	GRIP	
7	58070741	0	SPRING	
8	F0847434000	0	BALL	
9	38112200	0	O-RING 3087 (22,00X2,62)	
10	52371679	0	LEVER	
11	52472430	0	SELECTOR FORK	
12	56173016	0	PLUG	

RS-M	RS-R	AR-M	AR-R
•	•	•	•

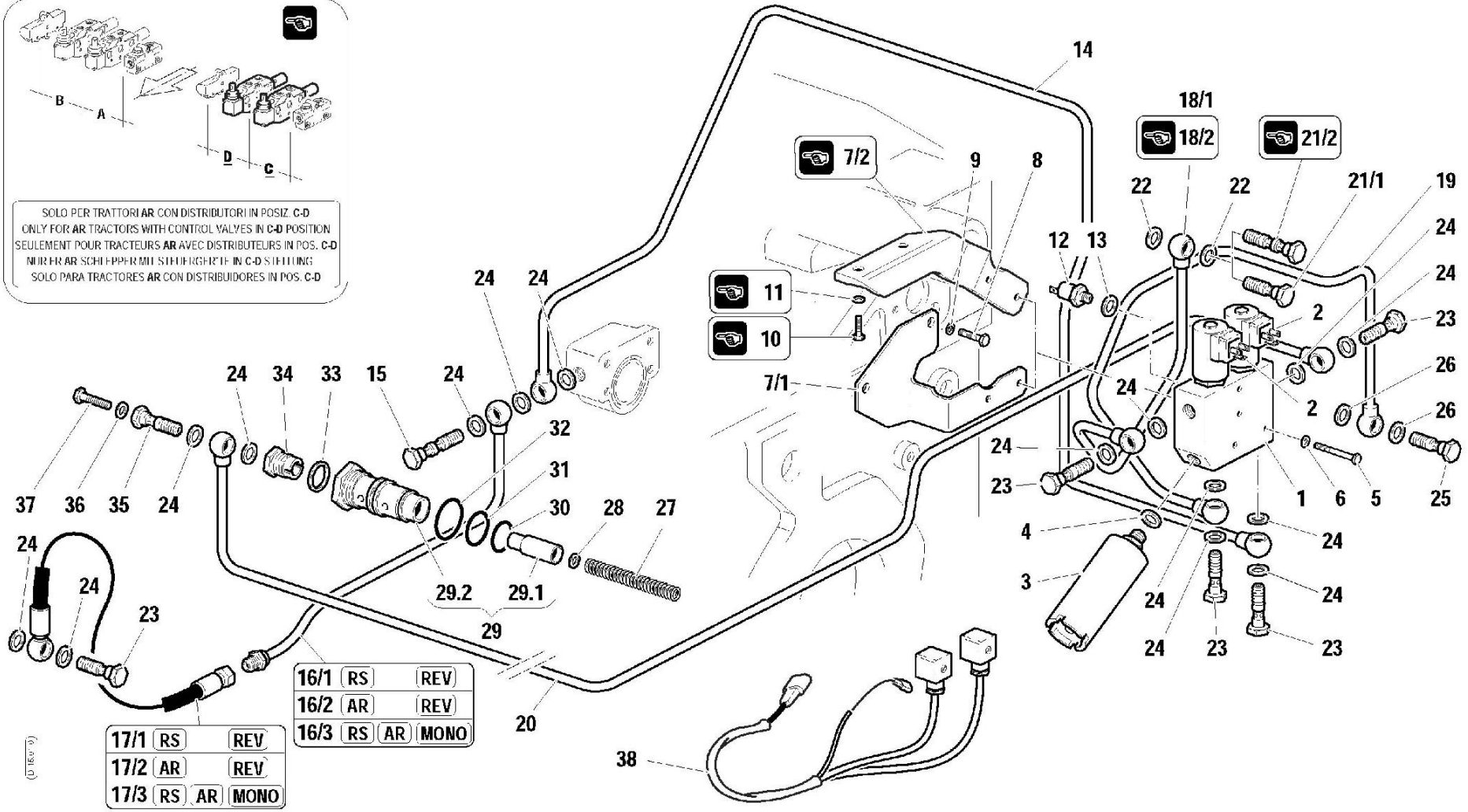
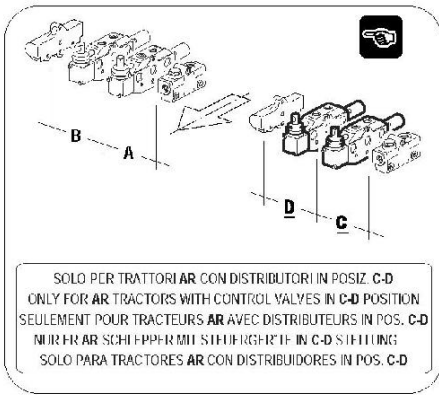

16/1	RS	REV	
16/2	AR	REV	
16/3	RS	AR	MONO
17/1	RS	REV	
17/2	AR	REV	
17/3	RS	AR	MONO

(D REV 0)

Pos.	Code	Q.ty	Description	Notes
1	56172749	0	SMALL BLOCK	
2	58172463	0	ELECTRO VALVE	
3	59271011	0	UNIT	
4	F0843948000	0	COPPER WASHER 14,0x20/1,5	
5	F0862345000	0	SCREW M6X40 UNI 5737	
6	F0843570000	0	WASHER 6	
7/1	56172759	0	BRACKET	
7/2	56172751	0	BRACKET	
8	31112150	0	SCREW TE M8X20 UNI 5739 8G	
9	F0843643060	0	WASHER 8	
10	31112090	0	SCREW TE M6X16 UNI 5739 8G	
11	F0843570000	0	WASHER 6	
12	58173399	0	PRESSURE SWITCH	
13	F0843841000	0	COPPER WASHER 12,0x18/1,5	
14	59072788	0	PRESSURE PIPE	
15	56170413	0	PIPE FITTING	
16/1	59072790	0	PRESSURE PIPE	
16/2	59072791	0	PRESSURE PIPE	
16/3	59074343	0	PRESSURE PIPE	
17/1	58070416	0	FLEXIBLE HOSE	
17/2	58072792	0	FLEXIBLE HOSE	
17/3	58074344	0	FLEXIBLE HOSE	
18/1	59072780	0	EXHAUST	
18/2	59072782	0	EXHAUST	
19	59072783	0	PRESSURE PIPE	
20	59072779	0	PRESSURE PIPE	
21/1	F0843109020	0	PIPE FITTING	
21/2	58172589	0	THREADED TERMINAL END	
22	F0824110000	0	COPPER WASHER 3/8 GAS	
23	F0843107000	0	PIPE FITTING GAS 1/4	
24	F0843907000	0	COPPER WASHER 13,66x19/1,5	
25	F0843102000	0	THR. TERMINAL END M10X1,25X20	
26	F0843771000	0	COPPER WASHER 10,0x16/1	
27	58073183	0	SPRING	

SERIAL

**P.T.O. WITH INDEPENDENT CLUTCH - DIFFERENTIAL GEAR LOCK WITH
ELECTROHYDRAULIC CO**

CODE REV

D1501_0_3724

RS-M	RS-R	AR-M	AR-R
•	•	•	•

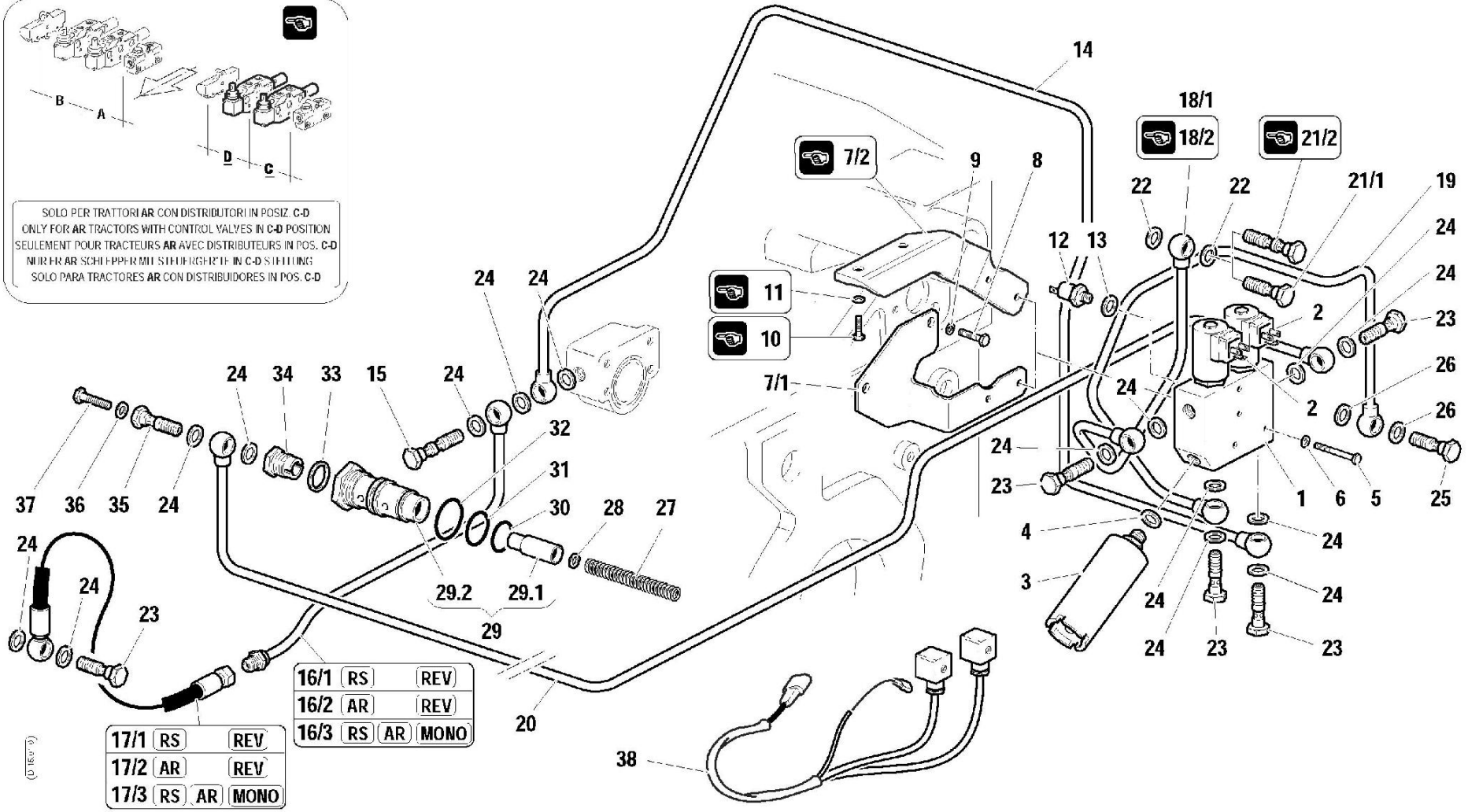
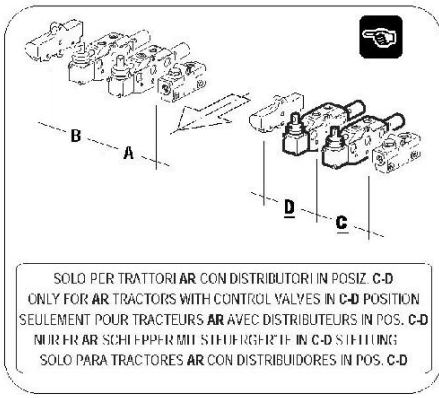

16/1	RS	REV	
16/2	AR	REV	
16/3	RS	AR	MONO
17/1	RS	REV	
17/2	AR	REV	
17/3	RS	AR	MONO

(D REV 0)

Pos.	Code	Q.ty	Description	Notes
28	F0843526000	0	WASHER 4,3x12/1,5	
29	59379589	1	COMPLETE MAX PRESSURE VALVE	
29.1	56470030	0	VALVE	
29.2	56572475	1	CASING	
30	F0803072050	0	O-RING 2093 (23,52x1,78)	
31	F0803204000	0	O-RING 3093 (23,47x2,62)	
32	38112982	0	O-RING	
33	F0844200050	0	COPPER WASHER 20,0x26/1,5	
34	56372474	0	PIPE CONNECTION	
35	58071806	0	PIPE FITTING	
36	F0843641000	0	COPPER WASHER 8x14/1,5	
37	F0862448100	0	SCREW M8X10 UNI 5740	
38	58073407	0	CABLE	

RS-M	RS-R	AR-M	AR-R
•	•	•	•

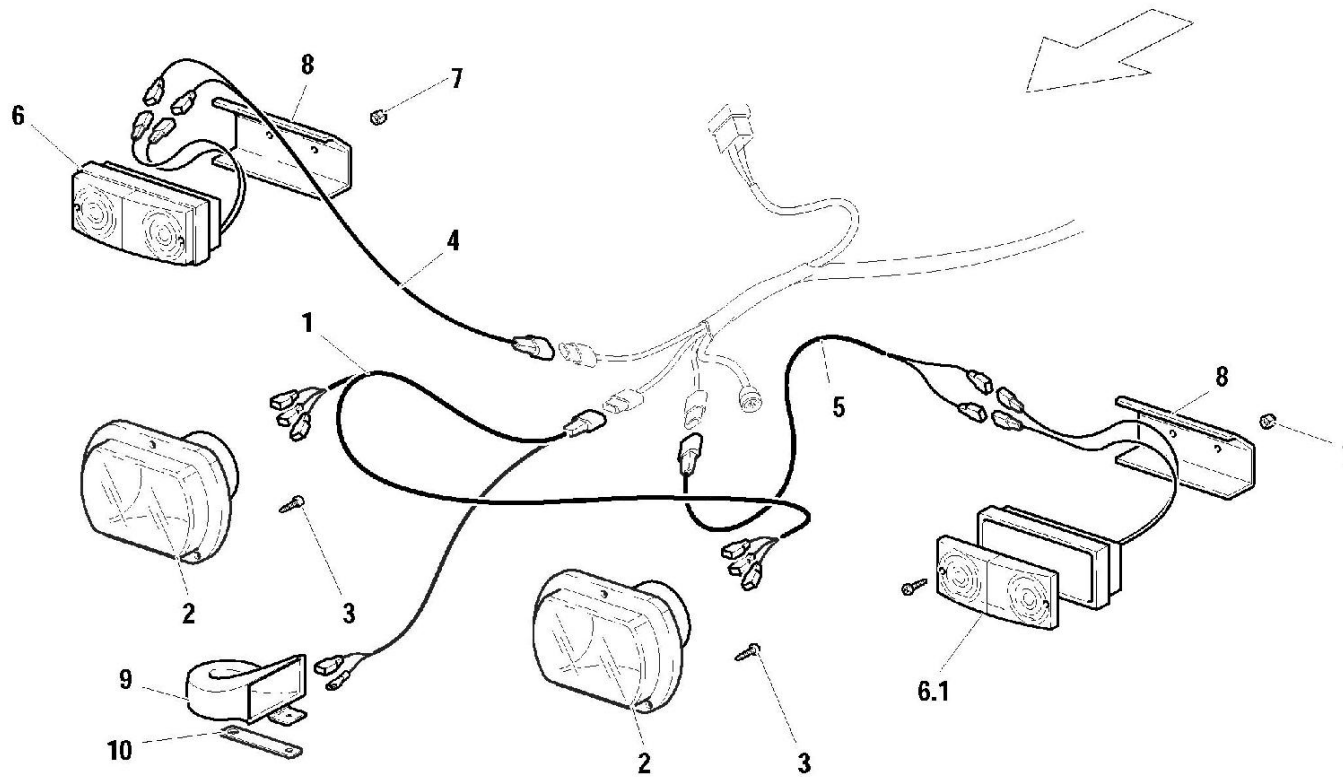

Pos.	Code	Q.ty	Description	Notes
1	58074377	0	CABLE	
2	F0825404050	0	HEADLIGHT	
3	F1000005108	0	SCREW A/F TCB 7981 4,8X13 ZNT	
4	58071308	0	CABLE	
5	58071307	0	CABLE	
6	F0825420500	0	LAMP	
6.1	F0825420560	0	GLASS	
7	F0814529080	0	SELFLOCK NUT M5	
8	56171938	0	BRACKET	
9	F0825417000	0	HORN	
10	56171233	0	SMALL PLATE	

RS-M	RS-R	AR-M	AR-R
•	•	•	•

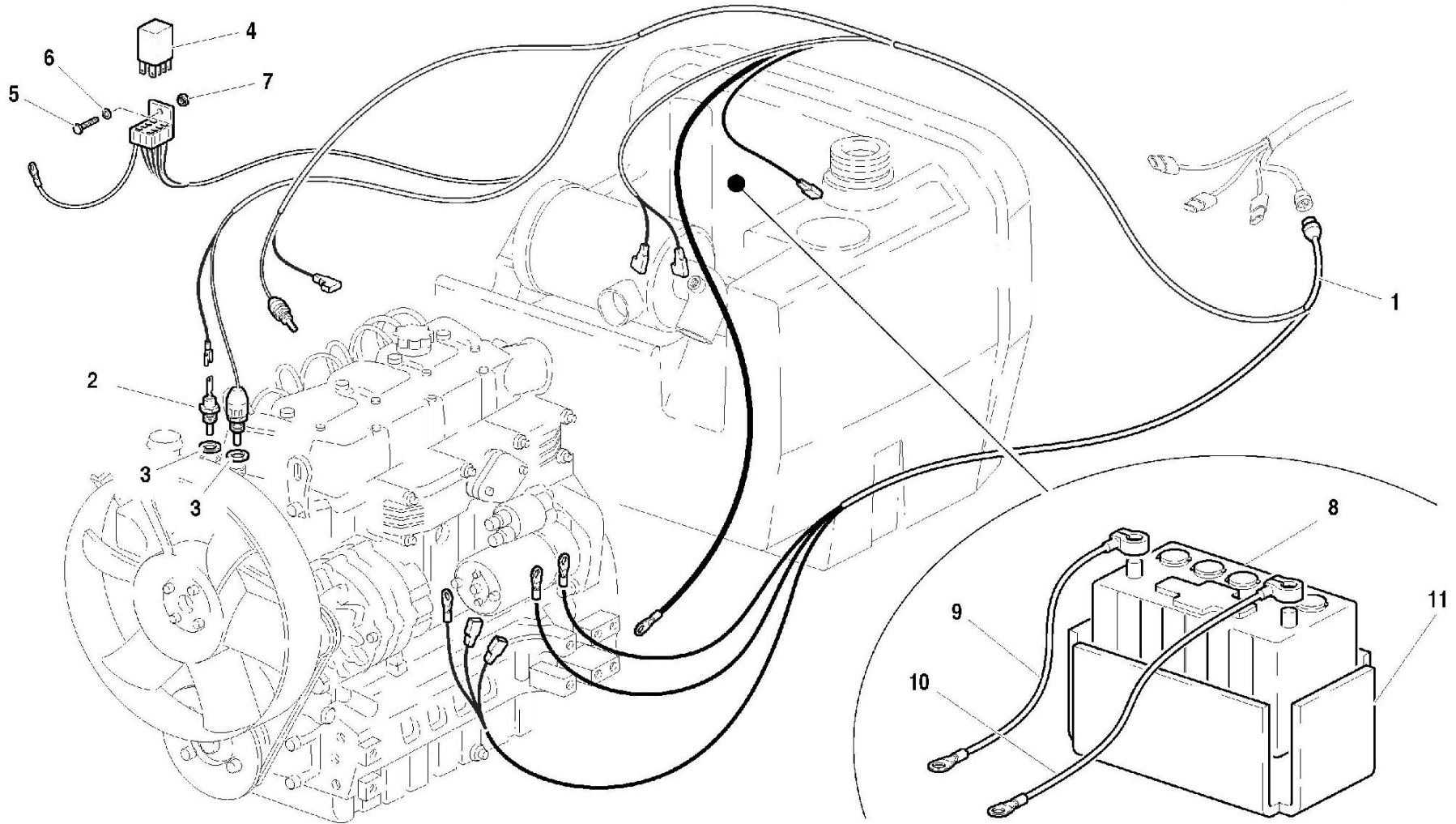

Pos.	Code	Q.ty	Description	Notes
1	58073596	0	CABLE	
2	58175773	1	ELECTRONICAL THERMOMETER	
3	F0844030070	0	COPPER WASHER 16,0x22/1,5	
4	F0834378001	0	CENTRAL PROCESSING UNIT	
5	F0861929060	0	SCREW M5X12 UNI 5739	
6	F0843561000	0	WASHER 5	
7	F0814525000	0	NUT M5	
8	F0825469050	0	BATTERY	
9	58071313	0	CABLE	
10	58072081	0	CABLE	
11	F0190018909	0	LINING	

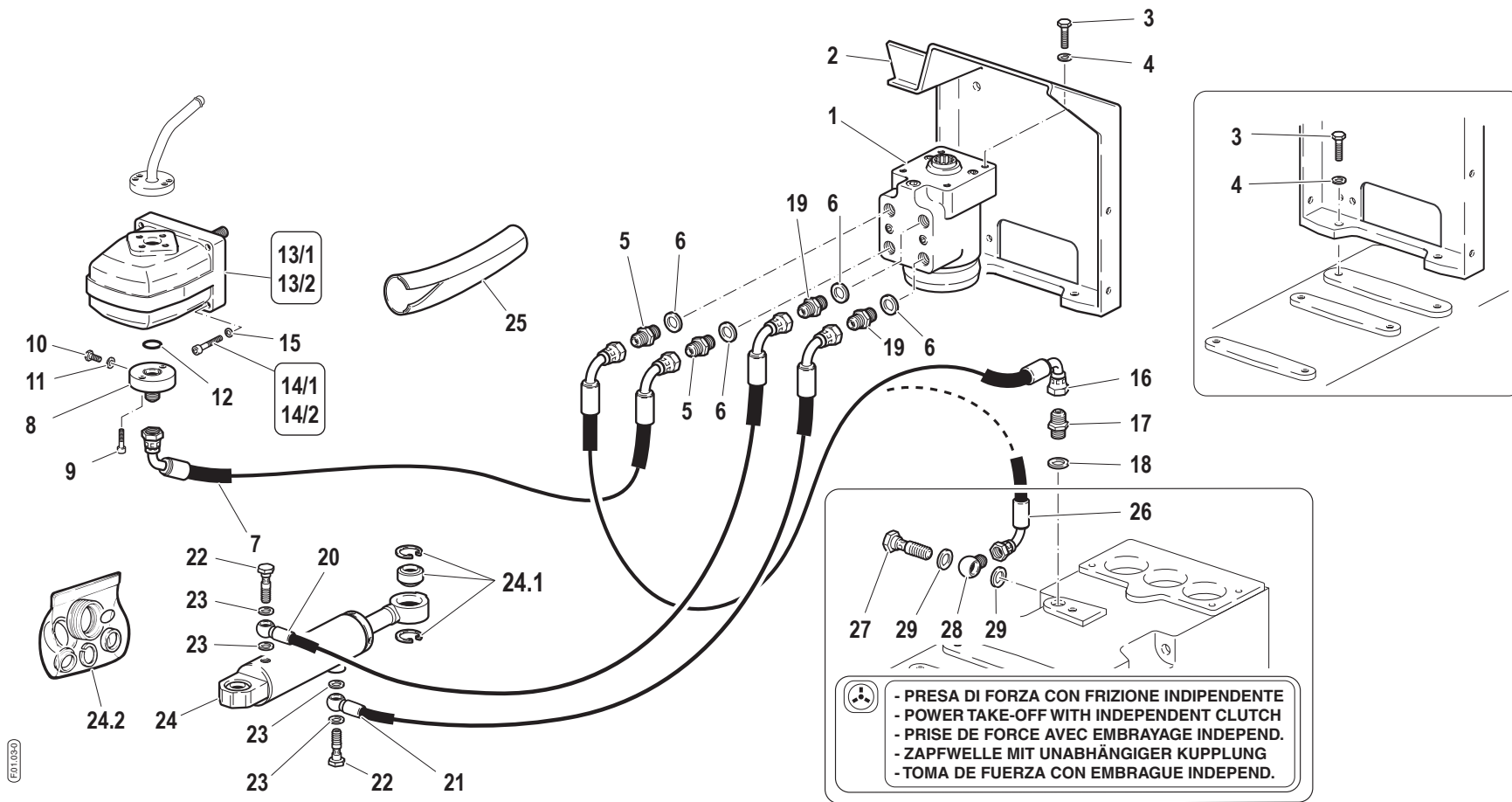

581.025A

Pos.	Code	Q.ty	Description	Notes
1	58176717	1	HYDROSTEERING	
2	59072974	0	SUPPORT	
3	31112219	0	SCREW TE M10X25 UNI 5739	
4	F0843755000	0	WASHER 10	
5	F0835037000	0	NIPPLE	
6	F0824141000	0	COPPER WASHER 21x27/1,5	
7	58072130	0	FLEXIBLE HOSE	
8	F0825809000	0	PRESSURE PIPE CONNECTOR	
9	31152057	0	SCREW TCEI M6X16 UNI 5931	
10	F0862462010	0	SCREW M8X1/12 UNI5740	
11	F0824022000	0	SPECIAL GASKET D.8,4X12/1	
12	F0803185000	0	O-RING 3068 (17,12x2,62)	
13/1	58174414	1	PUMP	
13/2	58177758	1	PUMP	
14/1	31152063	1	SCREW TCEI M6X20 UNI 5931	
14/2	31152060	1	SCREW TCEI M6X30 UNI 5931	
15	31411064	0	WASHER 6,4x12,5	
16	58072137	0	FLEXIBLE HOSE	
17	F0835024010	0	NIPPLE	
18	F0824110000	0	COPPER WASHER 3/8 GAS	
19	F0835040000	0	NIPPLE	
20	58072133	0	FLEXIBLE HOSE	
21	58072134	0	FLEXIBLE HOSE	
22	F0843109000	0	PIPE FITTING 14x1,5	
23	F0843948000	0	COPPER WASHER 14,0x20/1,5	
24	58174019	0	STEERING CYLINDER	
24.1	59900178	0	BUSHINGS KIT	
24.2	59900247	0	GASKET SET	
25	57372345	0	SHIELD	
26	58072793	0	FLEXIBLE HOSE	
27	F0843109020	0	PIPE FITTING	
28	F0842505030	0	PIPE FITTING	
29	F0824110000	0	COPPER WASHER 3/8 GAS	

SERIAL

STEERING HYDRAULIC SYSTEM

CODE REV

F0103_0_3917

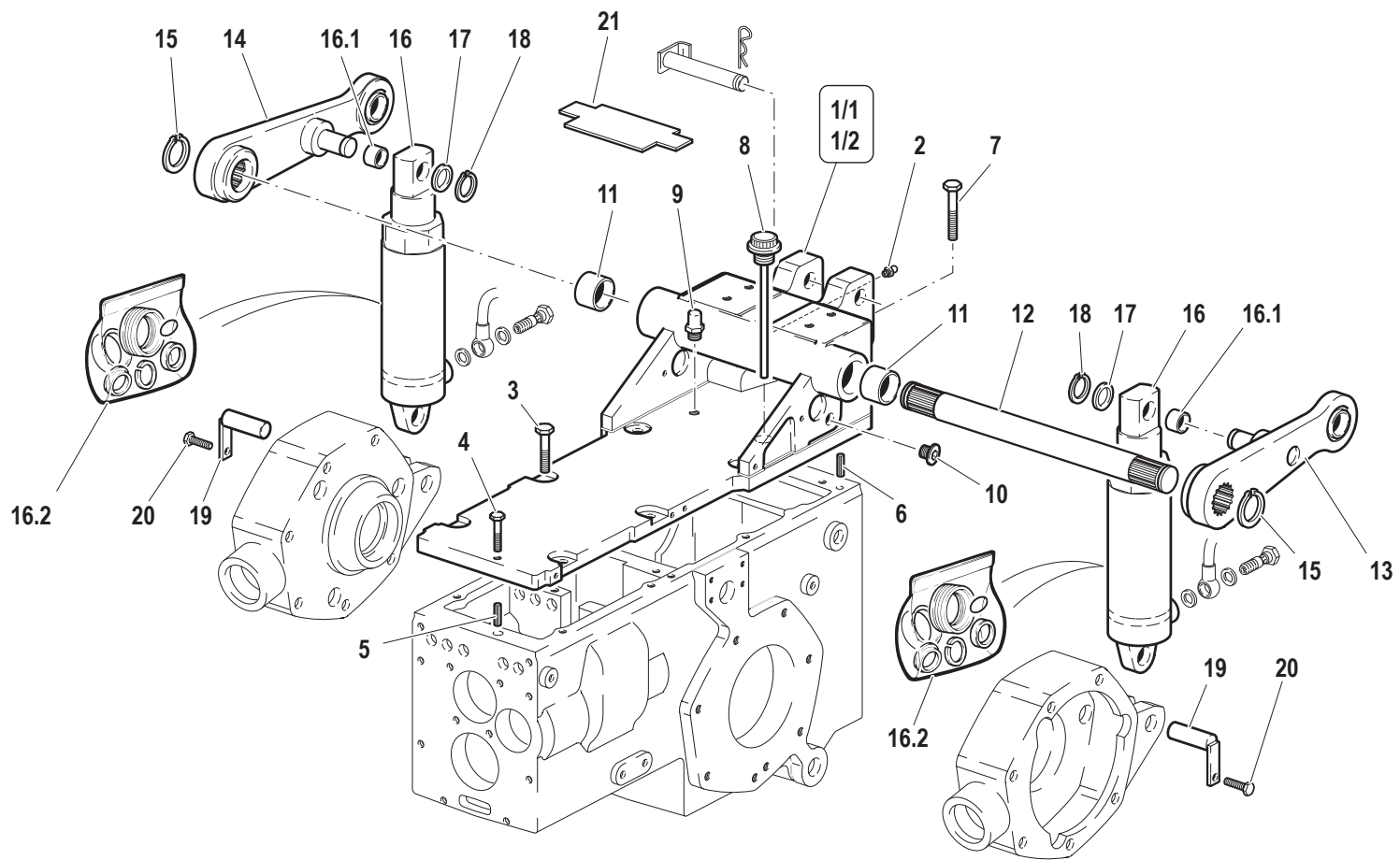

Pos.	Code	Q.ty	Description	Notes
1/1	51171641	1	SUPPORT	
1/2	51178584	1	SUPPORT	
2	F0826056000	0	LUBRICATOR M10 UNI 7663A	
3	31112219	0	SCREW TE M10X25 UNI 5739	
4	31112154	0	SCREW TE M8X40 UNI 5739 8G	
5	56170017	0	PIN	
6	56370228	0	CYLINDRICAL PLUG	
7	F0863328000	0	SCREW M10X35 UNI 5737	
8	58071805	0	PLUG	
9	30040005	0	PLUG	
10	58072045	0	PLUG	
11	58171861	0	BUSHING	
12	56571785	0	SHAFT	
13	59071783	0	LIFTING ARM	
14	59071771	0	RIGHT ARM	
15	F0801264050	0	SEEGER RING E 35X2,5 U/7436	
16	58071534	0	LIFTING CYLINDER	
16.1	59900180	0	BUSHING	
16.2	59900181	0	GASKET SET	
17	56172905	0	THRUST PLATE	
18	F0801149010	0	SEEGER RING E 20 7436D/471-2	
19	59071786	0	HINGE PIN	
20	31111151	0	SCREW TE M8X16 UNI 5739 8G	
21	573A0715	1	RUBBER	

RS-M	RS-R	AR-M	AR-R
		•	•

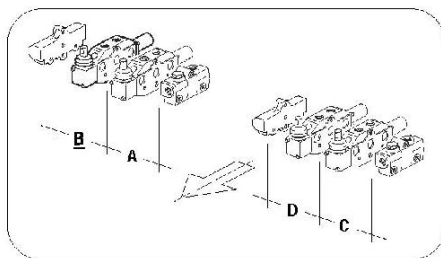

➔ - VEDI TAVOLA...
- SEE TABLE...
- VOIR TABLE...
- SIEHE TAFEL...
- MIRAR TABLA...
I.01.02-0

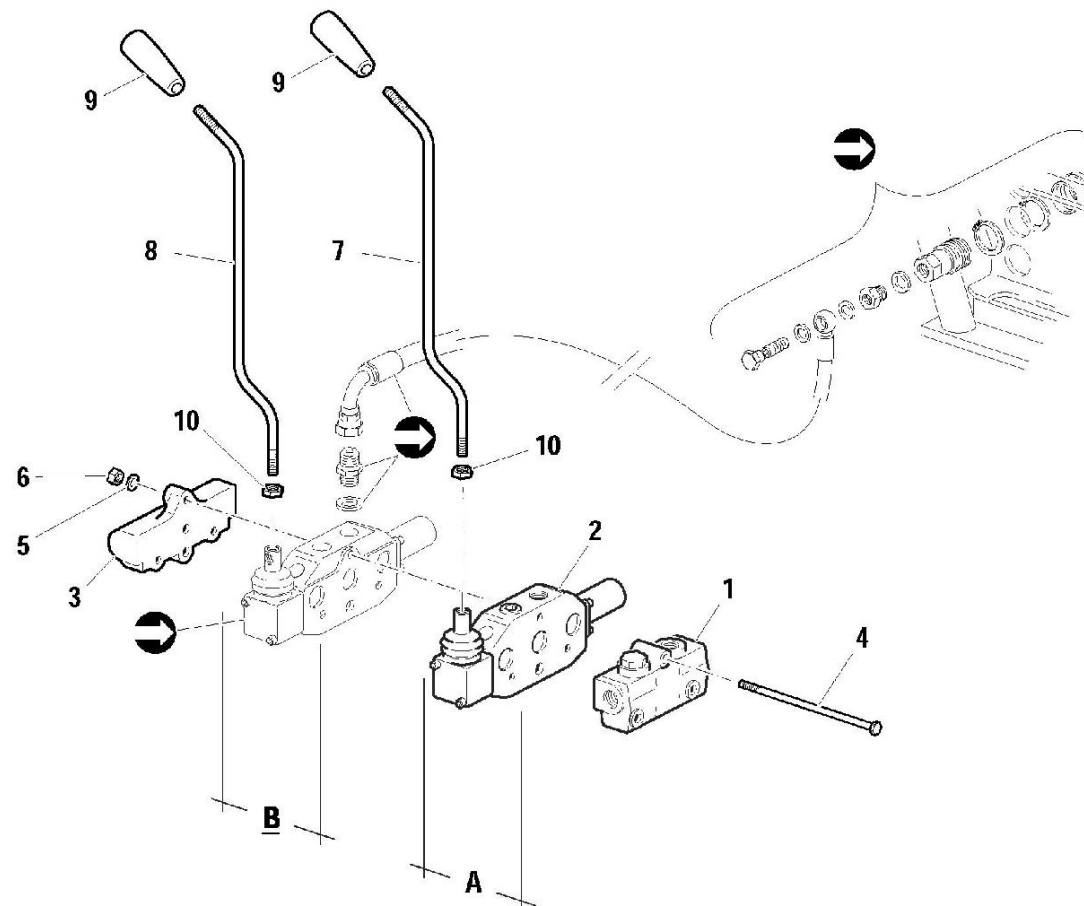

Pos.	Code	Q.ty	Description	Notes
1	58172304	0	HEAD	
2	58172011	0	S.A. VALVE	
3	58172489	0	COVER	
4	58172016	0	ROD	
5	F0843643060	0	WASHER 8	
6	31211080	0	NUT M8	
7	56172769	0	COMMAND LEVER	
8	56172770	0	COMMAND LEVER	
9	F0837534010	0	GRIP	
10	31211100	0	NUT M10	

SERIAL

ONE ADDITIONAL CONTROL VALVE FOR "AR"

CODE REV

G0302_0_4169

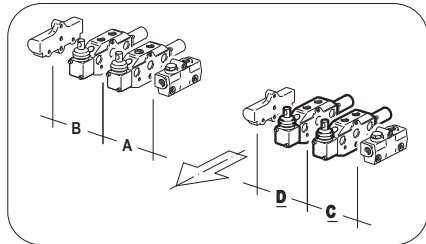

- VEDI TAVOLA...
 - SEE TABLE...
 - VOIR TABLE...
 - SIEHE TAFSEL...
 - MIRAR TABLA...

I.01.02-0

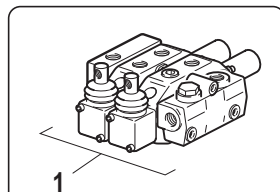

- GRUPPO DISTRIBUTORI CON "CARRY OVER"
 - CONTROL VALVES UNIT WITH "CARRY OVER"
 - GROUPE DES DISTRIBUTEURS AVEC "CARRY OVER"
 - STEUERGERÄTEGRUPPE MIT "CARRY OVER"
 - GRUPO DISTRIBUIDORES CON "CARRY OVER"

010102

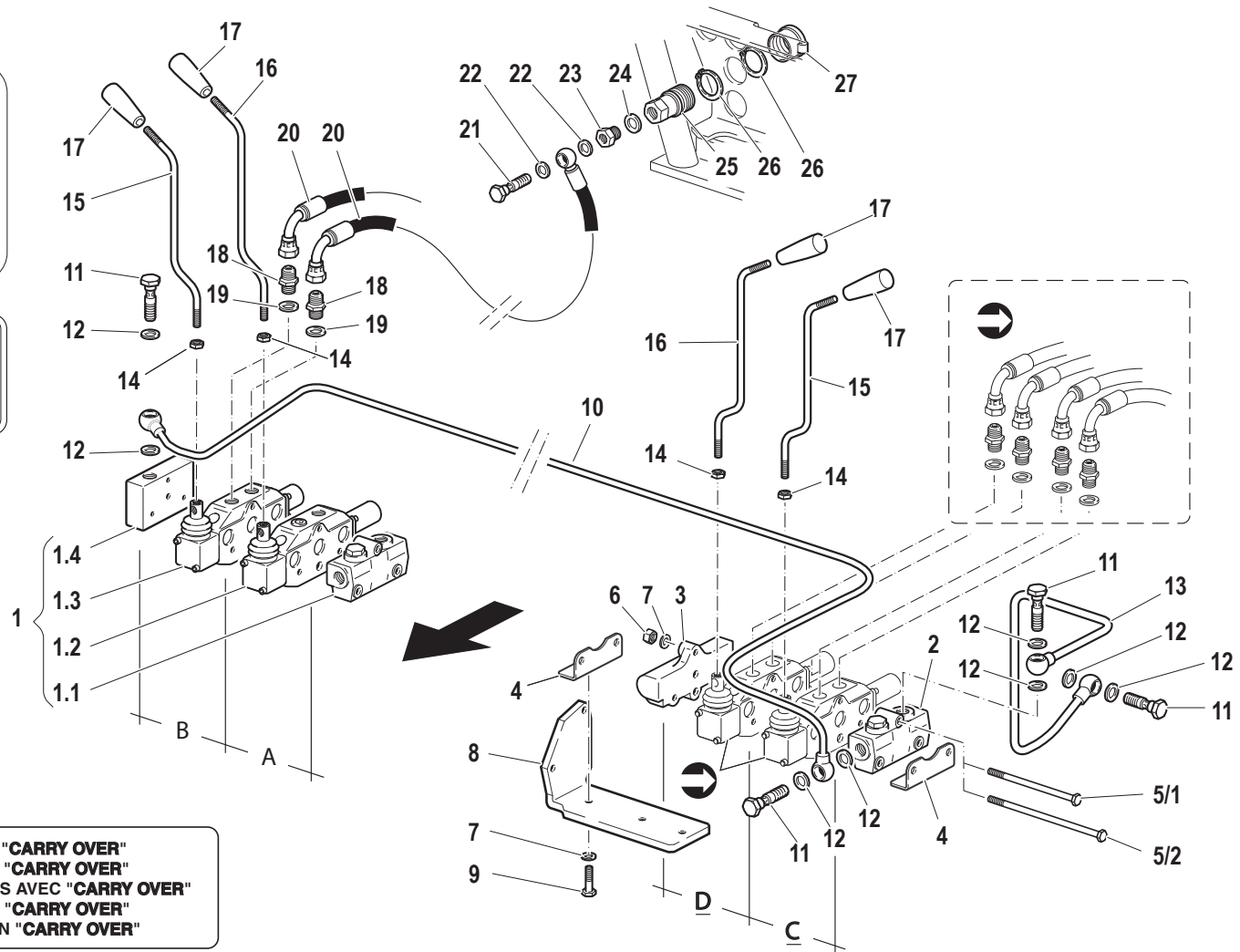

Pos.	Code	Q.ty	Description	Notes
1	58172274	0	FLOATING DEVICE GROUP	
1.1	58172304	0	HEAD	
1.2	58172011	0	S.A. VALVE	
1.3	58172012	0	D.A. VALVE	
1.4	58173361	0	COVER	
3	58172489	0	COVER	
4	59072057	0	FIXING BRACKET	
5/1	58172490	0	ROD	
5/2	58172016	0	ROD	
6	31211080	0	NUT M8	
7	F0843643060	0	WASHER 8	
8	56172750	0	RETAINER	
9	31112146	0	SCREW TE M8X22 UNI 5739 8G	
10	59075593	1	PIPE	
11	F0843109020	0	PIPE FITTING	
12	F0824110000	0	COPPER WASHER 3/8 GAS	
13	59072787	0	EXHAUST	
14	31211100	0	NUT M10	
15	56172770	0	COMMAND LEVER	
16	56172769	0	COMMAND LEVER	
17	F0837534010	0	GRIP	
18	F0835023000	0	NIPPLE	
19	F0824110000	0	COPPER WASHER 3/8 GAS	
20	58072138	0	FLEXIBLE HOSE	
21	F0843107000	0	PIPE FITTING GAS 1/4	
22	F0843907000	0	COPPER WASHER 13,66x19/1,5	
23	F0835040020	0	REDUCTION	
24	F0824141000	0	COPPER WASHER 21x27/1,5	
25	F0825980030	0	COUPLING	
26	F0801297000	0	SEEGER RING E 40 UNI 7435	
27	F0852550010	0	GUARD	

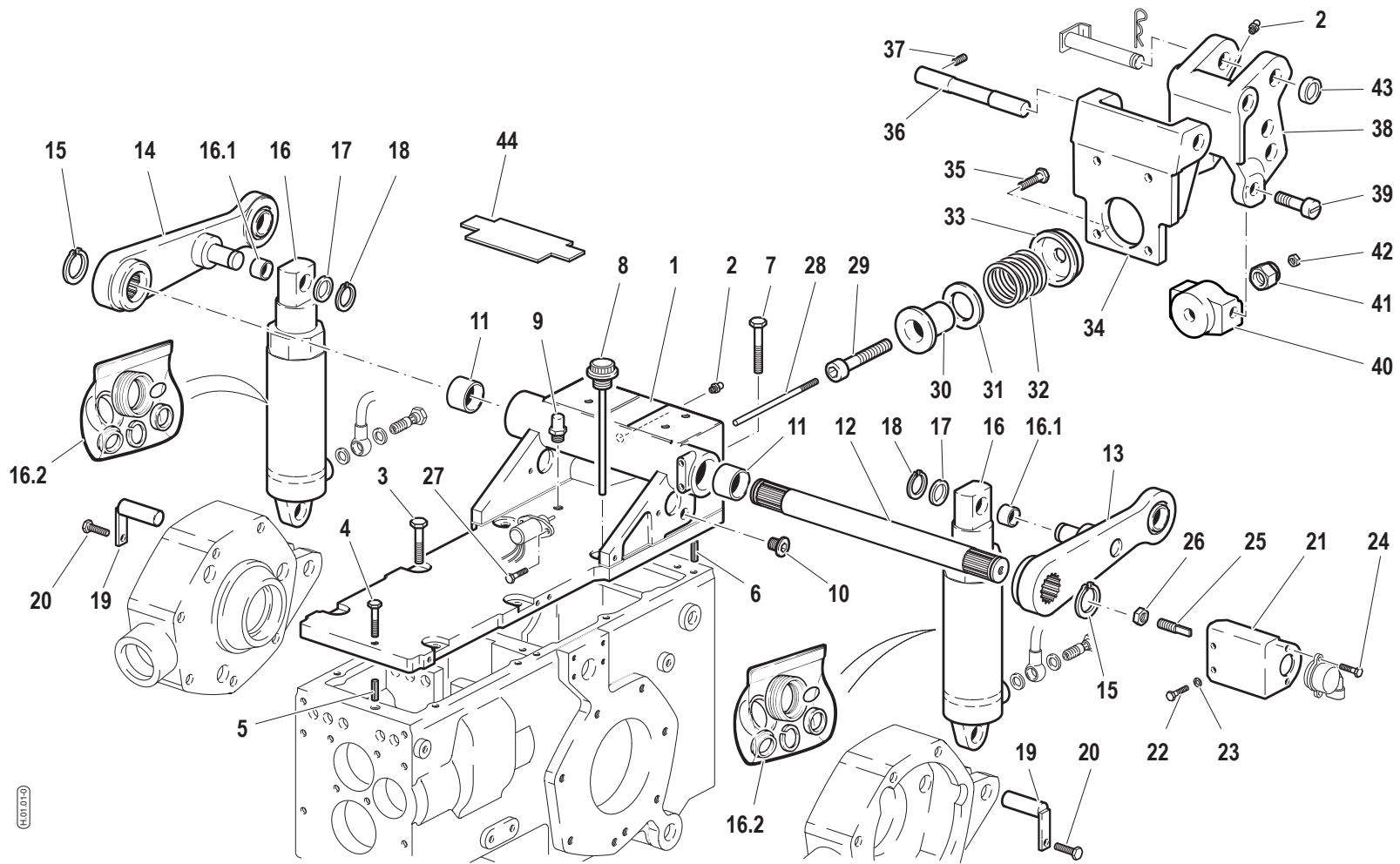

Pos.	Code	Q.ty	Description	Notes
1	51172366	0	SUPPORT	
2	F0826056000	0	LUBRICATOR M10 UNI 7663A	
3	31112219	0	SCREW TE M10X25 UNI 5739	
4	31112154	0	SCREW TE M8X40 UNI 5739 8G	
5	56170017	0	PIN	
6	56370228	0	CYLINDRICAL PLUG	
7	F0863358000	0	SCREW TE M10X40 UNI 5737	
8	58071805	0	PLUG	
9	30040005	0	PLUG	
10	58072045	0	PLUG	
11	58171861	0	BUSHING	
12	56571785	0	SHAFT	
13	59071783	0	LIFTING ARM	
14	59071771	0	RIGHT ARM	
15	F0801264050	0	SEEGER RING E 35X2,5 U/7436	
16	58071534	0	LIFTING CYLINDER	
16.1	59900180	0	BUSHING	
16.2	59900181	0	GASKET SET	
17	56172905	0	THRUST PLATE	
18	F0801149010	0	SEEGER RING E 20 7436D/471-2	
19	59071786	0	HINGE PIN	
20	31111151	0	SCREW TE M8X16 UNI 5739 8G	
21	56173022	0	SUPPORT	
22	31111091	0	SCREW E M6X14 UNI 5739 8G	
23	F0843570000	0	WASHER 6	
24	31112049	0	SCREW TE M4X10 UNI 5739 8G	
25	56172926	0	PIN	
26	F0814627000	0	NUT M10	
27	F0861929060	0	SCREW M5X12 UNI 5739	
28	56172483	0	PIN	
29	58072484	0	SCREW	
30	56072960	0	SLEEVE	
31	56372952	0	SHIM	
31	56372953	0	SHIM	

SERIAL

ELECTRONIC CONTROL LIFT (LIFT SUPPORT)

CODE REV

H0101_0_4286

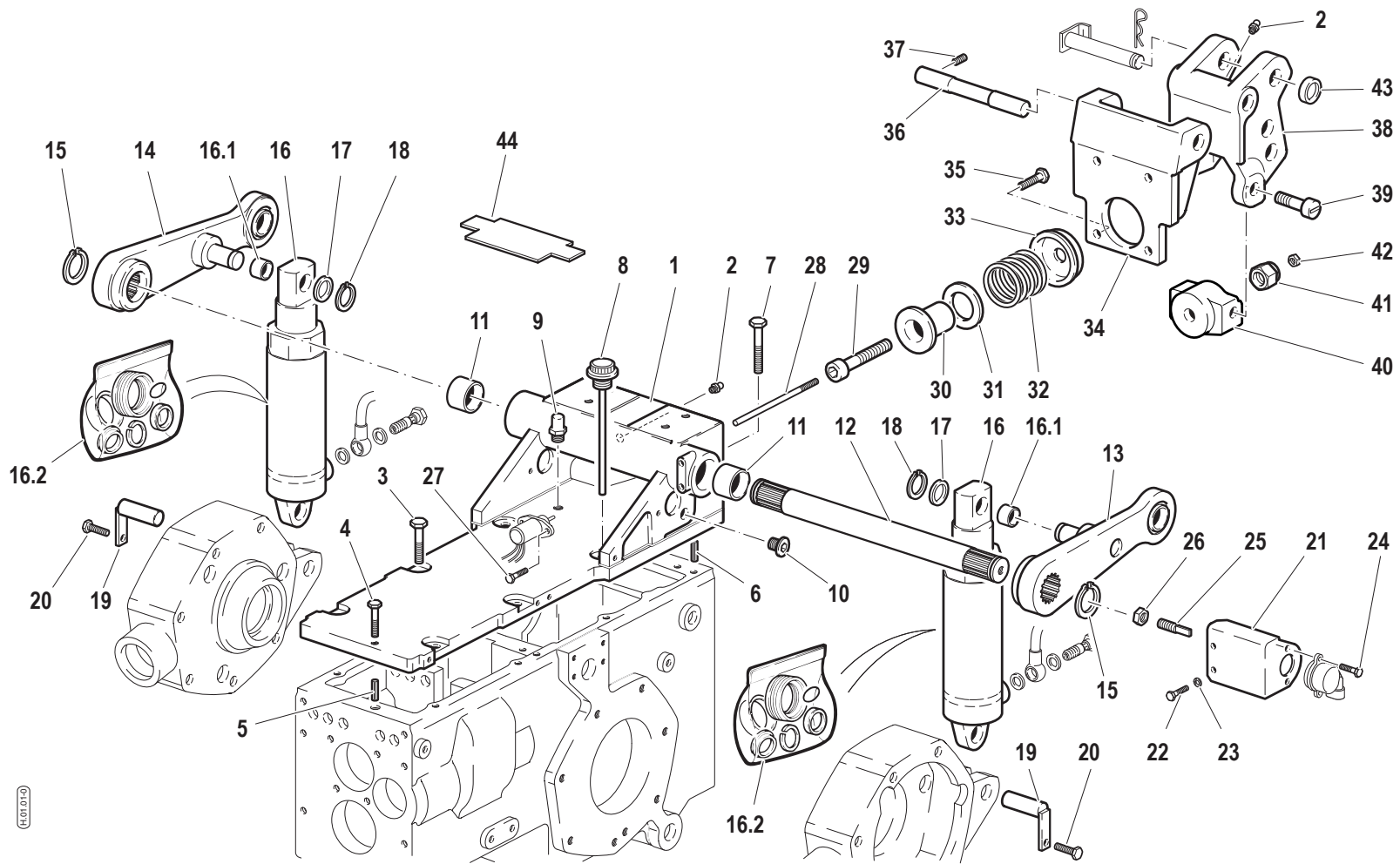

Pos.	Code	Q.ty	Description	Notes
31	56372954	0	SHIM	
31	56372955	0	SHIM	
32	58073192	0	SPRING	
33	56073148	0	SLEEVE	
34	51372479	0	BRACKET	
35	31112211	0	SCREW TE M10X30 UNI 5739	
36	56472318	0	HINGE PIN	
37	F0862443010	0	SCREW M8X10 UNI 5927	
38	51173115	0	THREE-POINT LINKAGE	
39	56572959	0	PIN	
40	51172962	0	SLEEVE	
41	31241142	0	SELFLOCK NUT M14x1,5	
42	F0814535050	0	NUT M6	
43	58071757	0	WASHER D.33x19,5/8	
44	573A0715	1	RUBBER	

RS-M	RS-R	AR-M	AR-R
		•	•

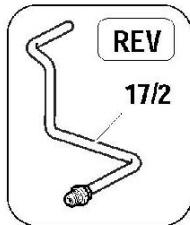

➔ - VEDI TAVOLA...
- SEE TABLE...
- VOIR TABLE...
- SIEHE TAFSEL...
- MIRAR TABLA...
I.01.02-0

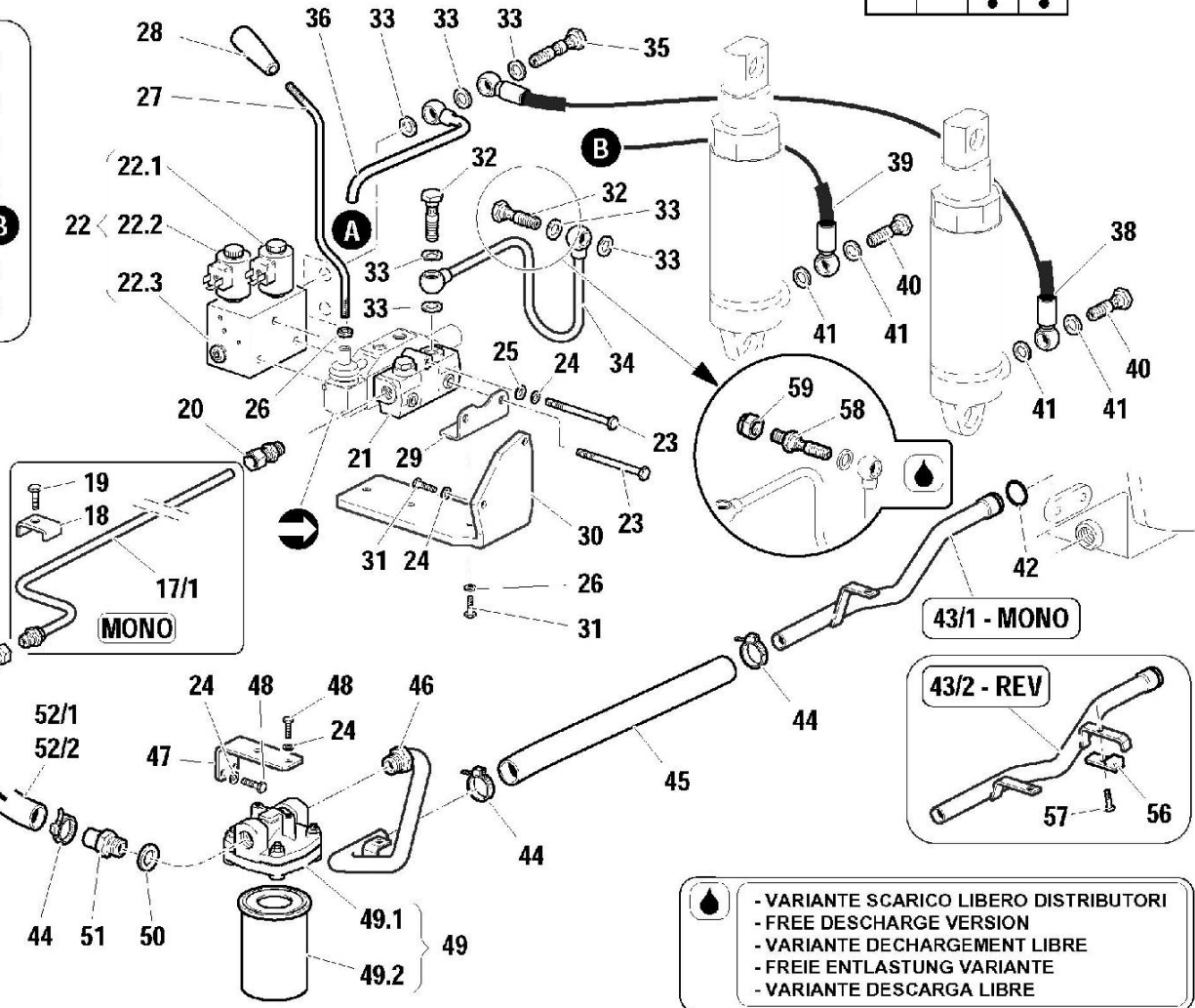
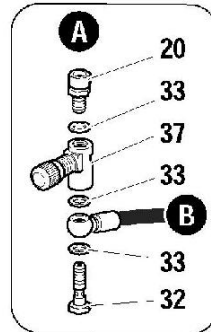

🔸 - VARIANTE SCARICO LIBERO DISTRIBUTORI
- FREE DISCHARGE VERSION
- VARIANTE DECHARGEMENT LIBRE
- FREIE ENTLASTUNG VARIANTE
- VARIANTE DESCARGA LIBRE

(PAG. 2/2)

Pos.	Code	Q.ty	Description	Notes
1	58173636	0	LIFT PUMP	
2	31152060	0	SCREW TCEI M6X30 UNI 5931	
3	31152064	0	SCREW TCEI M6X25 UNI 5931	
4	31411064	0	WASHER 6,4x12,5	
5	F0803185000	0	O-RING 3068 (17,12x2,62)	
6	59074413	0	SUCTION PIPE	
7	31152057	0	SCREW TCEI M6X16 UNI 5931	
8	F0817514000	0	CLAMP	
9	F0256612913	0	PIPE	
10	59074412	0	SUCTION PIPE	
11	F0862345000	0	SCREW M6X40 UNI 5737	
12	F0843570000	0	WASHER 6	
13	F0825809000	0	PRESSURE PIPE CONNECTOR	
14	F0862462010	0	SCREW M8X1/12 UNI5740	
15	F0824022000	0	SPECIAL GASKET D.8,4X12/1	
16/1	58072470	0	FLEXIBLE HOSE	
16/2	58072800	0	FLEXIBLE HOSE	
16/3	58072132	0	FLEXIBLE HOSE	
16/4	58072799	0	FLEXIBLE HOSE	
17/1	59072145	0	PIPE	
17/2	59072785	0	PRESSURE PIPE	
18	56172183	0	BRACKET	
19	31112146	0	SCREW TE M8X22 UNI 5739 8G	
20	58172015	0	PIPE FITTING	
21	58172304	0	HEAD	
22	58173143	0	UNIT	
22.1	59900231	0	PRESSURE VALVE	
22.2	59900232	0	BLOW VALVE	
22.3	59900225	0	BLOCCH SOLL ELETTR SF/C 36-48	
23	31112158	0	SCREW TE M8X70 UNI 5737 8G	
24	F0843643060	0	WASHER 8	
25	31411084	0	WASHER 8,4x17	
26	31211100	0	NUT M10	
27	56172769	0	COMMAND LEVER	

SERIAL

ELECTRONIC CONTROL LIFT (HYDRAULIC SYSTEM)

CODE REV

H0202_0_4405

RS-M	RS-R	AR-M	AR-R
		•	•

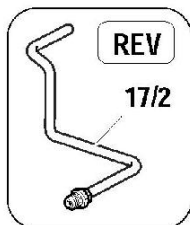

➔ - VEDI TAVOLA...
- SEE TABLE...
- VOIR TABLE...
- SIEHE TAFTEL...
- MIRAR TABLA...
I.01.02-0

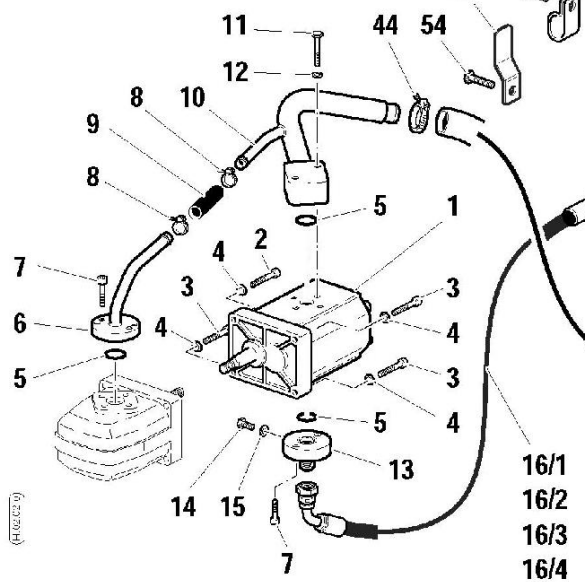
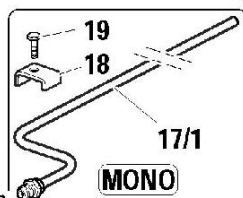
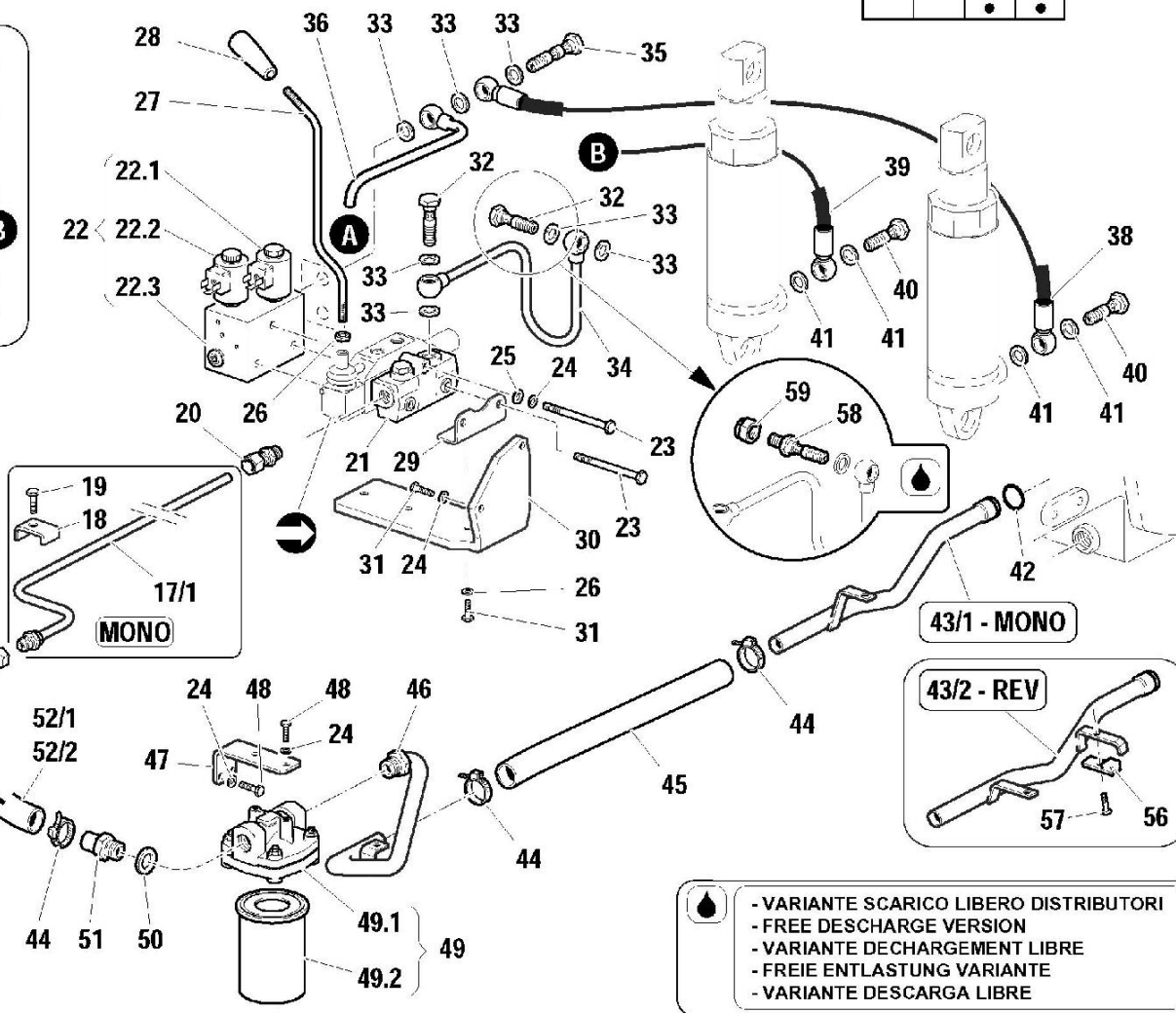
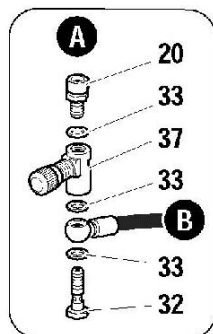

• - VARIANTE SCARICO LIBERO DISTRIBUTORI
- FREE DISCHARGE VERSION
- VARIANTE DECHARGEMENT LIBRE
- FREIE ENTLASTUNG VARIANTE
- VARIANTE DESCARGA LIBRE

Pos.	Code	Q.ty	Description	Notes
28	F0837534010	0	GRIP	
29	59072057	0	FIXING BRACKET	
30	56172561	0	RETAINER	
31	31112146	0	SCREW TE M8X22 UNI 5739 8G	
32	F0843109020	0	PIPE FITTING	
33	F0824110000	0	COPPER WASHER 3/8 GAS	
34	59073160	0	EXHAUST	
35	58172589	0	THREADED TERMINAL END	
36	59074664	0	PRESSURE PIPE	
37	P24117100000	0	VALVE	
38	58073020	0	FLEXIBLE HOSE	
39	58073544	0	FLEXIBLE HOSE	
40	F0843107000	0	PIPE FITTING GAS 1/4	
41	F0843907000	0	COPPER WASHER 13,66x19/1,5	
42	38112507	0	O-RING 3100 (25,07X2,62)	
43/1	59072410	0	SUCTION PIPE	
43/2	59072893	0	SUCTION PIPE	
44	F0817523010	0	CLAMP	
45	58170352	0	FLEXIBLE HOSE	
46	59072408	0	SUCTION PIPE	
47	56172411	0	FILTER SUPPORT	
48	31111151	0	SCREW TE M8X16 UNI 5739 8G	
49	F0825718000	0	FILTER	
49.1	F0825718010	0	FILTER HEAD	
49.2	F0825718020	0	FILTER INSERT	
50	F0824185000	0	COPPER WASHER 26X34X1,5	
51	56170350	0	PIPE FITTING	
52/1	58172607	0	FLEXIBLE HOSE	
52/2	58172907	0	FLEXIBLE HOSE	
53	56173247	0	BRACKET	
54	31112270	0	SCREW TE M12X20 UNI 5739	
55	58073300	0	HOSE CLIP	
56	59072826	0	BRACKET	
57	31112089	0	SCREW TE M6X25 UNI 5739 8G	

SERIAL

ELECTRONIC CONTROL LIFT (HYDRAULIC SYSTEM)

CODE REV

H0202_0_4405

RS-M	RS-R	AR-M	AR-R
		•	•

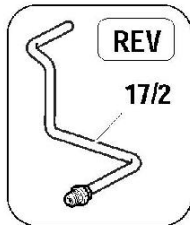

➔ - VEDI TAVOLA...
- SEE TABLE...
- VOIR TABLE...
- SIEHE TAFSEL...
- MIRAR TABLA...
I.01.02-0

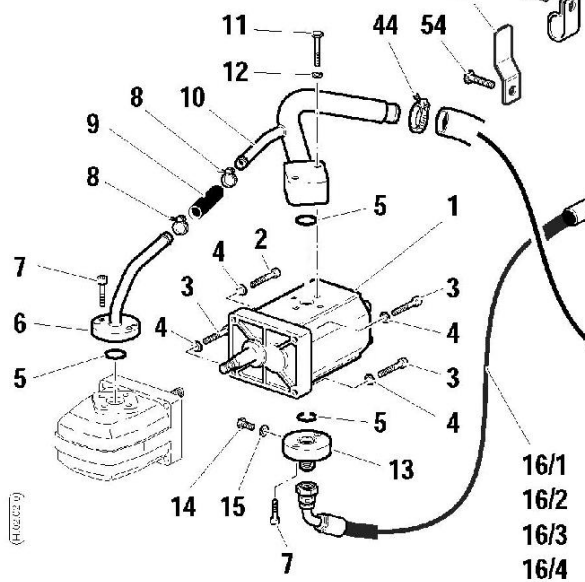
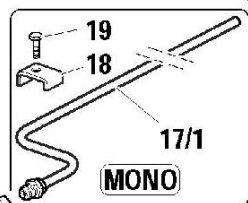
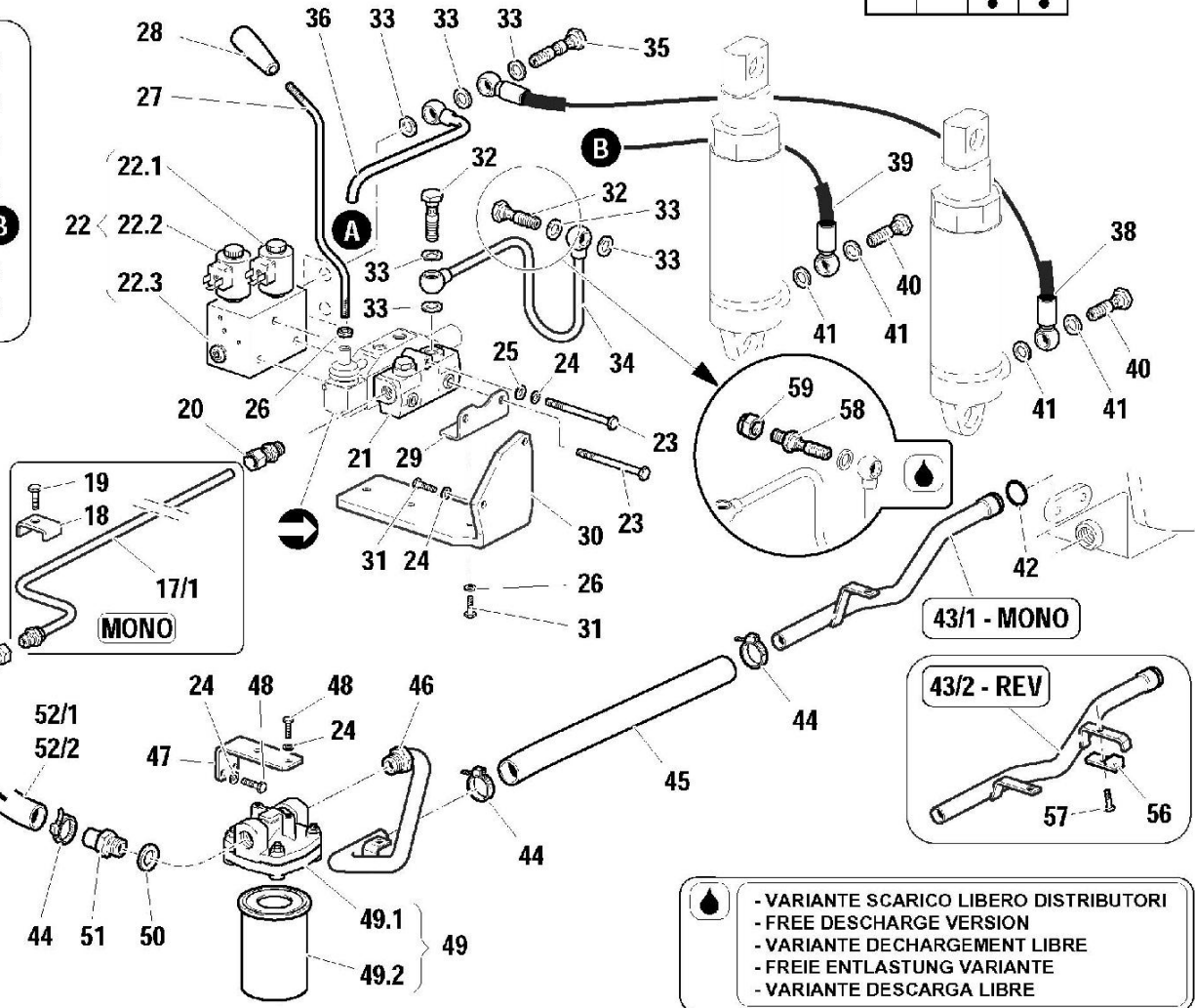
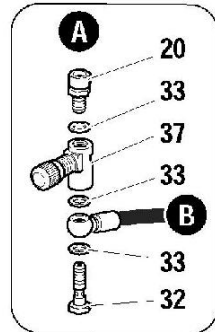

• - VARIANTE SCARICO LIBERO DISTRIBUTORI
- FREE DISCHARGE VERSION
- VARIANTE DECHARGEMENT LIBRE
- FREIE ENTLASTUNG VARIANTE
- VARIANTE DESCARGA LIBRE

(PAG. 2/2)

Pos.	Code	Q.ty	Description	Notes
58	56373163	0	PIPE UNION	
59	F0852589000	0	PLUG	

1 O 2 DISTRIBUTORI SUPPLEMENTARI PER "AR" CON SOLLEV. A CONTROLLO ELETRR.
 1 OR 2 ADDITIONAL CONTROL VALVES FOR "AR" WITH ELECTR. LIFT
 1 OU 2 DISTRIBUTEURS SUPPLEMENTAIRES POUR "AR" AVEC RELEVAGE A CONTROLE ELECTR.
 1 ODER 2 ZUSATZSTEUERGERÄTE FÜR "AR" SCHLEPPER MIT ELEKTR. HUBSTEUERUNG
 1 O 2 DISTRIBUIDORES ADICIONALES PARA "AR" CON ELEVADOR ELECTRONICO

RS-M	RS-R	AR-M	AR-R
		•	•

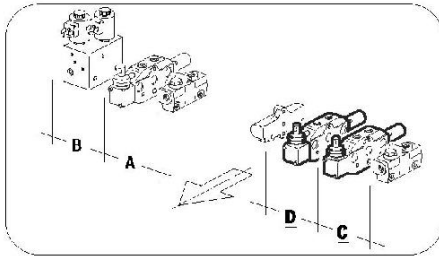

➡ - VEDI TAVOLA...
 - SEE TABLE...
 - VOIR TABLE...
 - SIEHE TAFEL...
 - MIRAR TABLA...
I.01.02-0

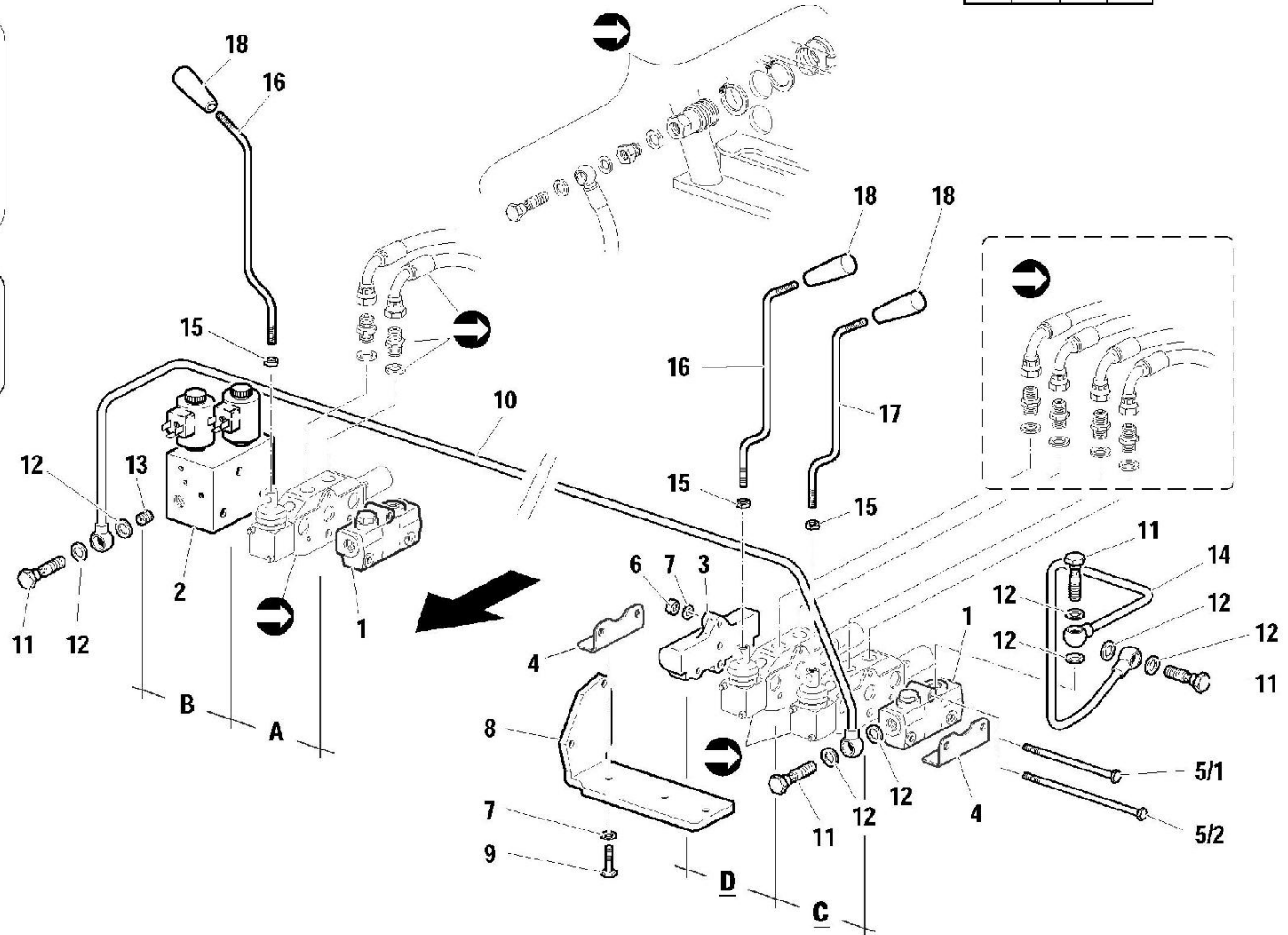

Pos.	Code	Q.ty	Description	Notes
1	58172304	0	HEAD	
2	58173143	0	UNIT	
3	58172489	0	COVER	
4	59072057	0	FIXING BRACKET	
5/1	58172490	0	ROD	
5/2	58172016	0	ROD	
6	31211080	0	NUT M8	
7	F0843643060	0	WASHER 8	
8	56172750	0	RETAINER	
9	31112146	0	SCREW TE M8X22 UNI 5739 8G	
10	59073021	0	PIPE	
11	F0843109020	0	PIPE FITTING	
12	F0824110000	0	COPPER WASHER 3/8 GAS	
13	F0852578060	0	CONICAL PLUG	
14	59072787	0	EXHAUST	
15	31211100	0	NUT M10	
16	56172769	0	COMMAND LEVER	
17	56172770	0	COMMAND LEVER	
18	F0837534010	0	GRIP	

RS-M	RS-R	AR-M	AR-R
•	•	•	•

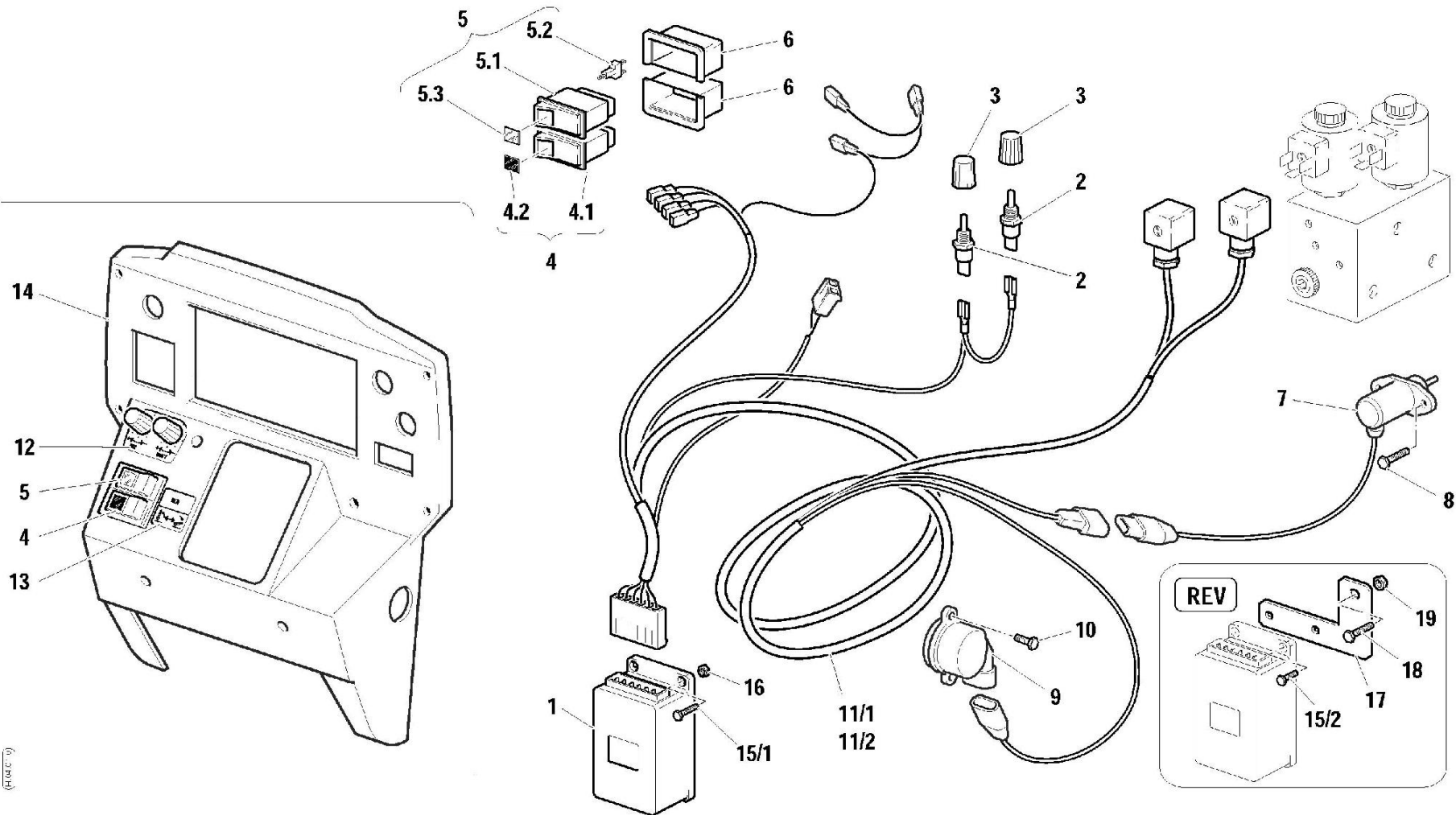

Pos.	Code	Q.ty	Description	Notes
1	58173144	0	CENTRAL PROCESSING UNIT	
2	58173866	0	POTENTIOMETER	
3	58172978	0	KNOB	
4	58172979	0	CHANGE-OVER SWITCH	
4.1	58173118	0	SWITCH	
4.2	58173123	0	GLASS	
5	58172980	0	CHANGE-OVER SWITCH	
5.1	58173117	0	SWITCH	
5.2	58173119	0	LAMP	
5.3	58173122	0	GLASS	
6	58170376	0	TERMINAL FOR SWITCH	
7	59073060	0	SENSOR	
8	F0861929060	0	SCREW M5X12 UNI 5739	
9	58172982	0	SENSOR	
10	31112049	0	SCREW TE M4X10 UNI 5739 8G	
11/1	58173864	0	WIRING	
11/2	58173865	0	WIRING	
12	58073018	0	PLATE	
13	58073019	0	PLATE	
14	55274442	0	INSTRUMENT PANEL	
15/1	31111084	0	SCREW TE M4X16 UNI 5739 8G	
15/2	31112049	0	SCREW TE M4X10 UNI 5739 8G	
16	31211040	0	NUT M4	
17	56173056	0	RETAINER	
18	31112082	0	SCREW TE M6X12 UNI 5739 8G	
19	31212060	0	NUT M6	

SERIAL

ELECTRONIC CONTROL LIFT (ELECTRICAL SYSTEM)

CODE REV

H0401_0_4504

RS-M	RS-R	AR-M	AR-R
		•	•

DISTRIBITORI DISPONIBILI
AVAILABLE CONTROL VALVES
DISTRIBUTEURS DISPONIBLES
VERFÜGBAR STEUERGERÄTE
DISTRIBUIDORES DISPONIBLES

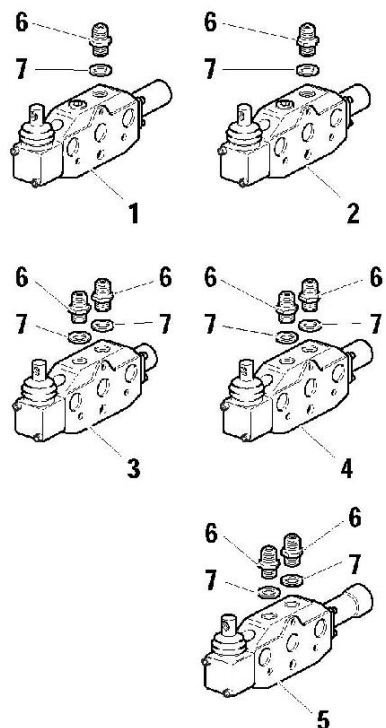

(10/01/01)

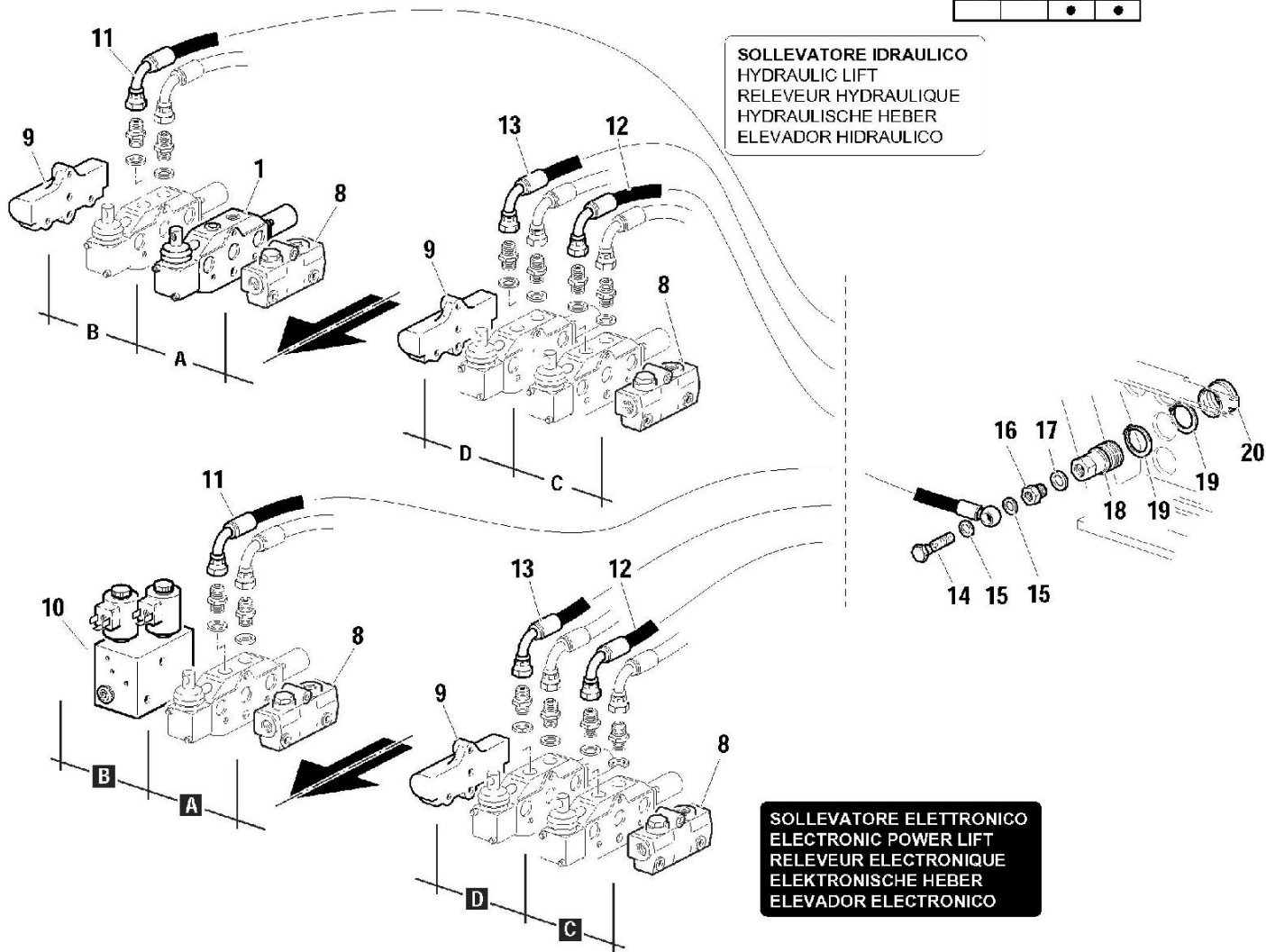

SOLLEVATORE IDRAULICO
HYDRAULIC LIFT
RELEVEUR HYDRAULIQUE
HYDRAULISCHE HEBER
ELEVADOR HIDRAULICO

SOLLEVATORE ELETTRONICO
ELECTRONIC POWER LIFT
RELEVEUR ELECTRONIQUE
ELEKTRONISCHE HEBER
ELEVADOR ELECTRONICO

Pos.	Code	Q.ty	Description	Notes
1	58172011	0	S.A. VALVE	
2	58172707	0	S.A. VALVE	
3	58172012	0	D.A. VALVE	
4	58172013	0	D.A. VALVE	
5	58172014	0	D.A. VALVE	
6	F0835023000	0	NIPPLE	
7	F0824110000	0	COPPER WASHER 3/8 GAS	
8	58172304	0	HEAD	
9	58172489	0	COVER	
10	58173143	0	UNIT	
11	58072138	0	FLEXIBLE HOSE	
12	58072795	0	FLEXIBLE HOSE	
13	58072796	0	FLEXIBLE HOSE	
14	F0843107000	0	PIPE FITTING GAS 1/4	
15	F0843907000	0	COPPER WASHER 13,66x19/1,5	
16	F0835040020	0	REDUCTION	
17	F0824141000	0	COPPER WASHER 21x27/1,5	
18	F0825980030	0	COUPLING	
19	F0801297000	0	SEEGER RING E 40 UNI 7435	
20	F0852550010	0	GUARD	

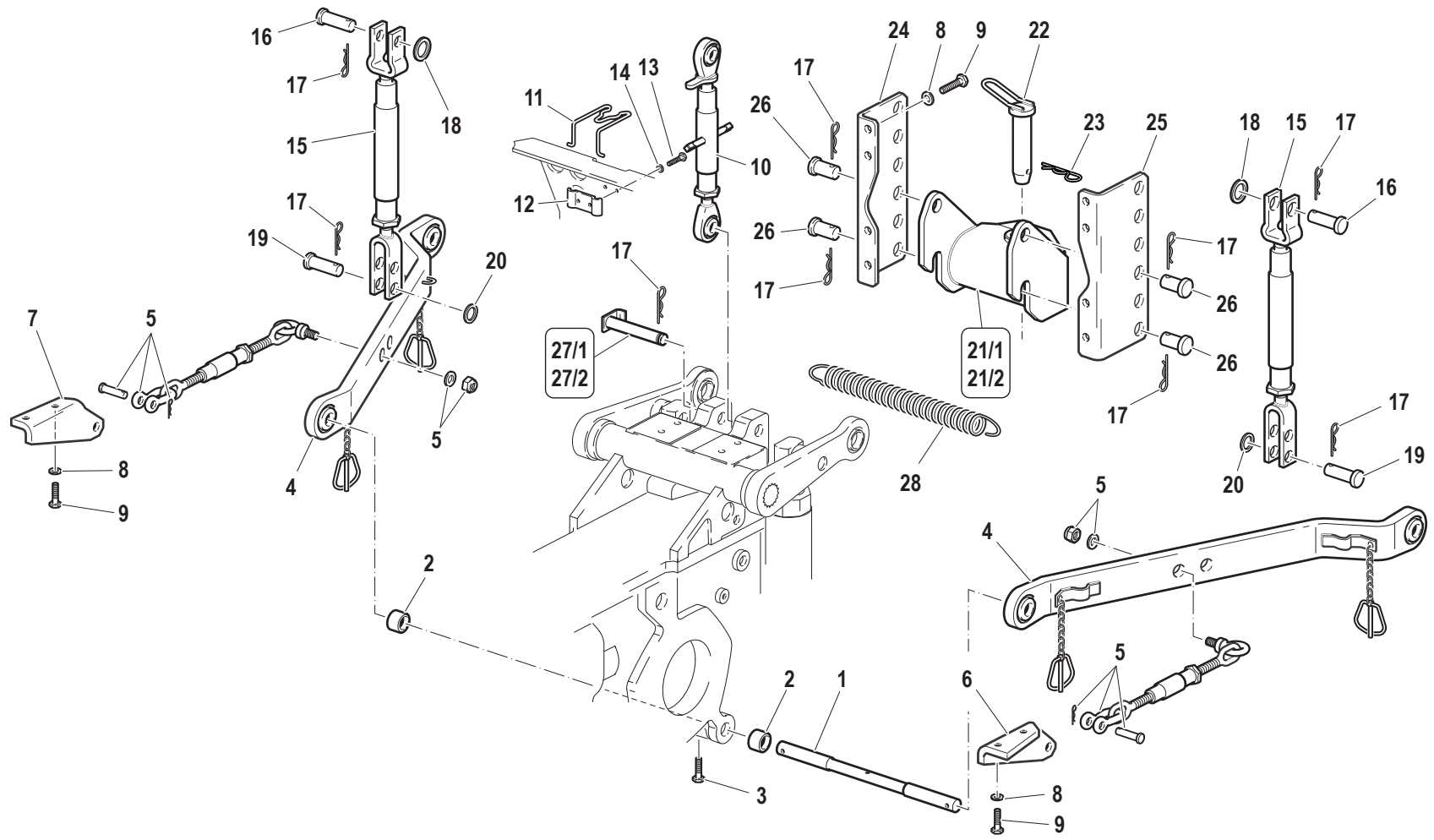

Pos.	Code	Q.ty	Description	Notes
1	56571824	0	PIN	
2	F0844283020	0	SPACER D.38x22/22	
3	31111151	0	SCREW TE M8X16 UNI 5739 8G	
4	59073045	0	BOTTOM LINK	
5	58071998	0	ROD	
6	56074233	0	SUPPORT	
7	56074234	0	SUPPORT	
8	F0843843060	0	WASHER 12	
9	31112272	0	SCREW TE M12X30 UNI 5739	
10	58176294	1	ROD	
11	58170449	0	RETAINING SPRING	
12	59070448	0	FIXING BRACKET	
13	31112150	0	SCREW TE M8X20 UNI 5739 8G	
14	F0843643060	0	WASHER 8	
15	58072626	0	ROD	
16	58072642	0	PIN	
17	F0851486000	0	SPLIT PIN	
18	31411190	0	WASHER 19x34	
19	56372086	0	PIN	
20	31411170	0	WASHER 17x30	
21/1	F0190031203	1	TOW HOOK	
21/2	590A0728	1	TOW HOOK	
22	F0808060100	0	LATCH D.28X117	
23	F0851497000	0	SPLIT PIN	
24	56171789	0	SUPPORT	
25	56171788	0	SUPPORT	
26	56372067	0	PIN	
27/1	56371210	1	CONNECTING BOLT	
27/2	59078588	1	CONNECTING BOLT	
28	58072465	0	RETAINING SPRING	

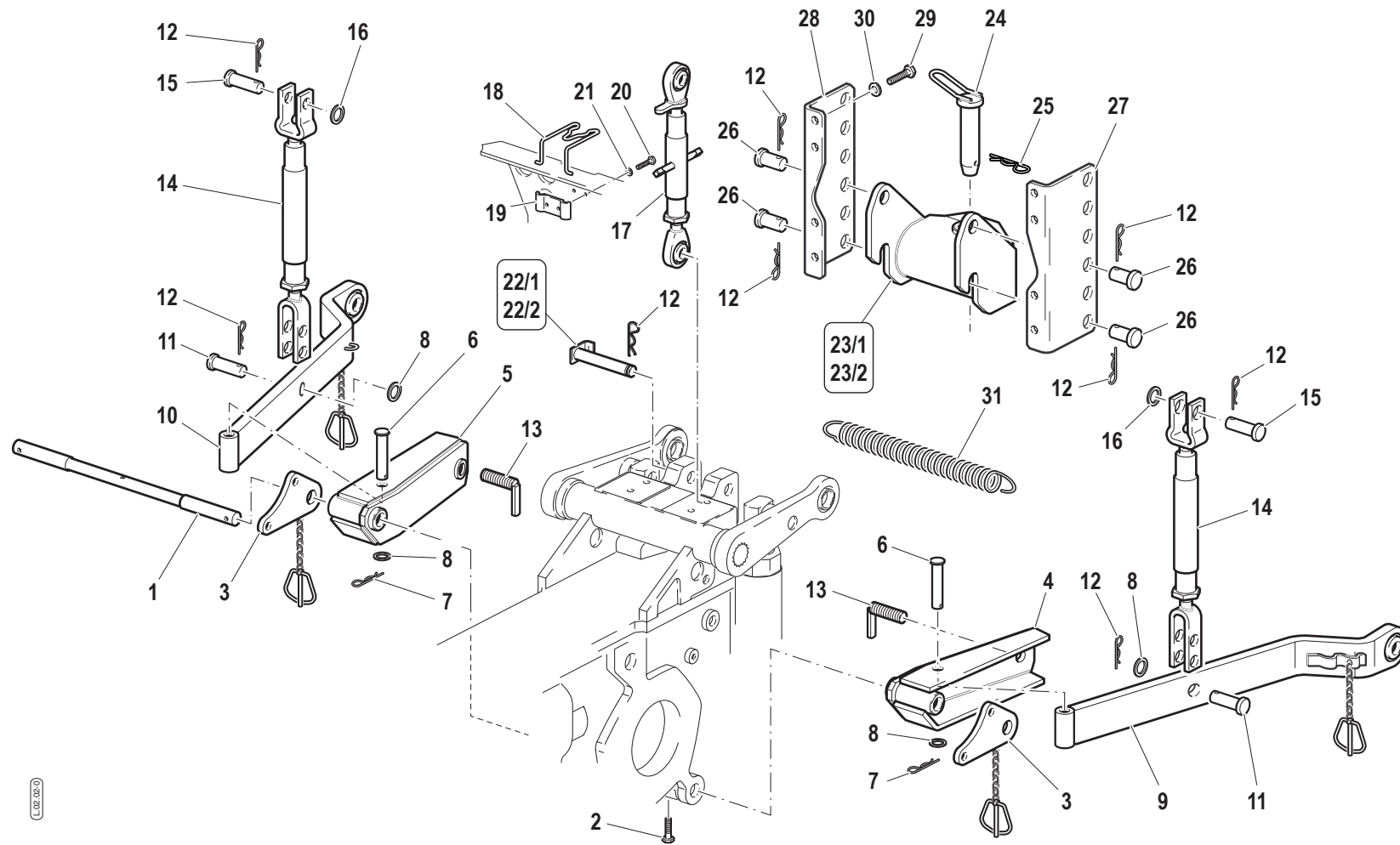

Pos.	Code	Q.ty	Description	Notes
1	56572337	0	ROD	
2	31111151	0	SCREW TE M8X16 UNI 5739 8G	
3	59272323	0	PLATE	
4	59072276	0	SUPPORT	
5	59072275	0	SUPPORT	
6	56372346	0	PIN	
7	F0810617050	0	SPLIT PIN A4X30 UNI 1336	
8	31411170	0	WASHER 17x30	
9	59072334	0	BOTTOM LINK	
10	59072330	0	BOTTOM LINK	
11	56372086	0	PIN	
12	F0851486000	0	SPLIT PIN	
13	59072347	0	PIN	
14	58072626	0	ROD	
15	58072642	0	PIN	
16	31411190	0	WASHER 19x34	
17	58176294	1	ROD	
18	58170449	0	RETAINING SPRING	
19	59070448	0	FIXING BRACKET	
20	31112150	0	SCREW TE M8X20 UNI 5739 8G	
21	F0843643060	0	WASHER 8	
22/1	56371210	1	CONNECTING BOLT	
22/2	59078588	1	CONNECTING BOLT	
23/1	F0190031203	1	TOW HOOK	
23/2	590A0728	1	TOW HOOK	
24	F0808060100	0	LATCH D.28X117	
25	F0851497000	0	SPLIT PIN	
26	56372067	0	PIN	
27	56171788	0	SUPPORT	
28	56171789	0	SUPPORT	
29	31112272	0	SCREW TE M12X30 UNI 5739	
30	F0843843060	0	WASHER 12	
31	58072465	0	RETAINING SPRING	

SERIAL

ATTACHMENT HITCH (VARIANT)

CODE REV

L0202_0_4630

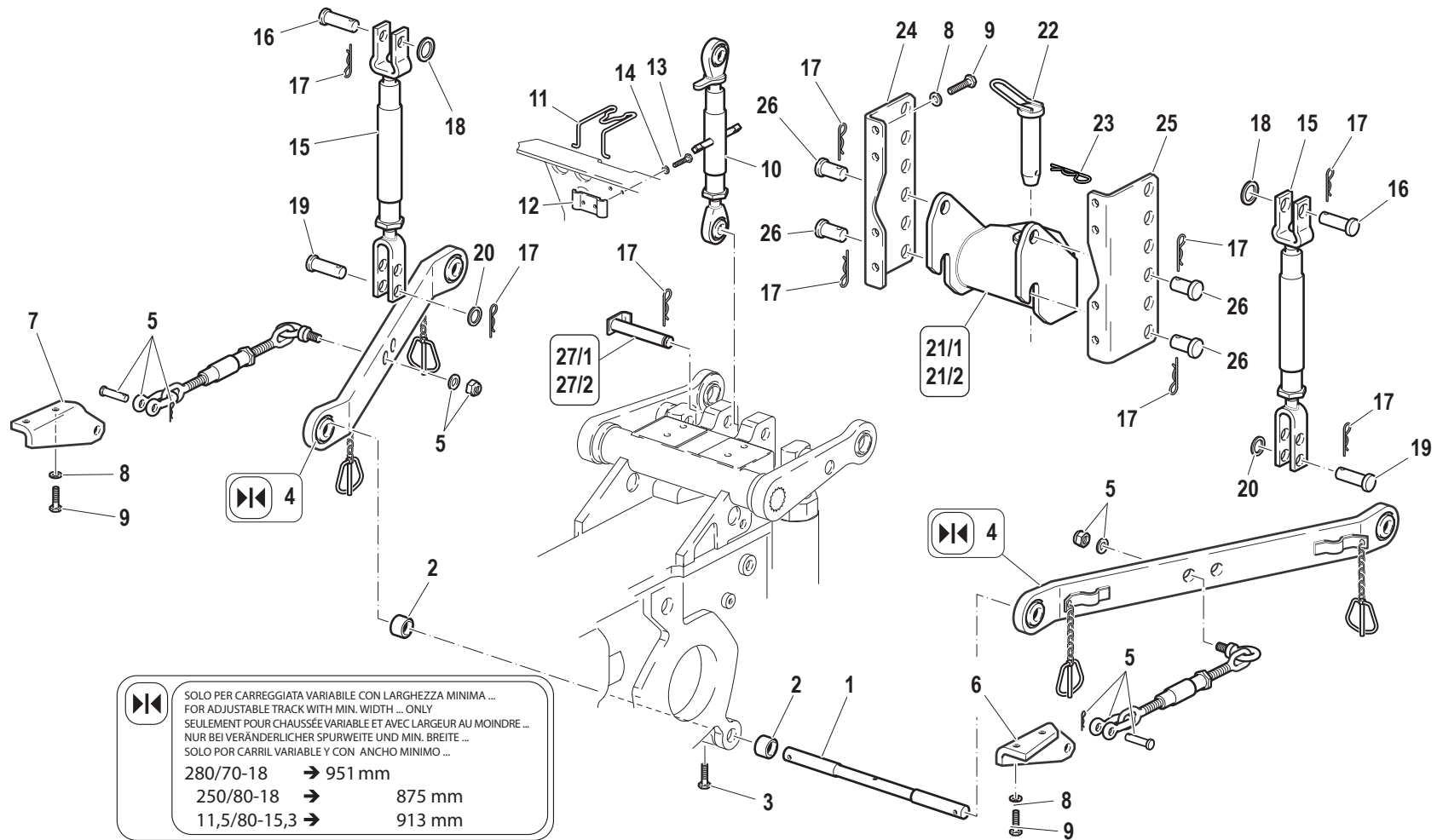

SOLO PER CARREGGIATA VARIABILE CON LARGHEZZA MINIMA ...
 FOR ADJUSTABLE TRACK WITH MIN. WIDTH ... ONLY
 SEULEMENT POUR CHAUSSÉE VARIABLE ET AVEC LARGEUR AU MOINDRE ...
 NUR BEI VERÄNDERLICHER SPURWEITE UND MIN. BREITE ...
 SOLO POR CARRIL VARIABLE Y CON ANCHO MINIMO ...

280/70-18	→	951 mm
250/80-18	→	875 mm
11,5/80-15,3	→	913 mm

Pos.	Code	Q.ty	Description	Notes
1	56571824	0	PIN	
2	F0844283020	0	SPACER D.38x22/22	
3	31111151	0	SCREW TE M8X16 UNI 5739 8G	
4	59071807	0	BOTTOM LINK	
5	58071998	0	ROD	
6	56074233	0	SUPPORT	
7	56074234	0	SUPPORT	
8	F0843843060	0	WASHER 12	
9	31112272	0	SCREW TE M12X30 UNI 5739	
10	F0060031247	0	3-POINT HITCH	
11	58170449	0	RETAINING SPRING	
12	59070448	0	FIXING BRACKET	
13	31112150	0	SCREW TE M8X20 UNI 5739 8G	
14	F0843643060	0	WASHER 8	
15	58072626	0	ROD	
16	58072642	0	PIN	
17	F0851486000	0	SPLIT PIN	
18	31411190	0	WASHER 19x34	
19	56372086	0	PIN	
20	31411170	0	WASHER 17x30	
21/14	F0190031203	1	TOW HOOK	
21/2	590A0728	1	TOW HOOK	
22	F0808060100	0	LATCH D.28X117	
23	F0851497000	0	SPLIT PIN	
24	56171789	0	SUPPORT	
25	56171788	0	SUPPORT	
26	56372067	0	PIN	
27/1	56371210	1	CONNECTING BOLT	
27/2	59078588	1	CONNECTING BOLT	

SERIAL

ATTACHMENT HITCH (STRAIGHT ARMS VERSION)

CODE REV

L0203_0_4662

RS-M	RS-R	AR-M	AR-R
•	•	•	•

VARIANTE NON COMPATIBILE CON QUELLA ILLUSTRATA IN TAVOLA...

VARIANT INCOMPATIBLE WITH THE ONE IN TABLE...

VARIANTE INCOMPATIBLE AVEC CELLE DE TABLE....

VARIANTE UNVEREINBAR MIT DIER IN TAFTEL...

VARIANTE INCOMPATIBLE CON AQUELLA DE TABLA...

L.02.02-0

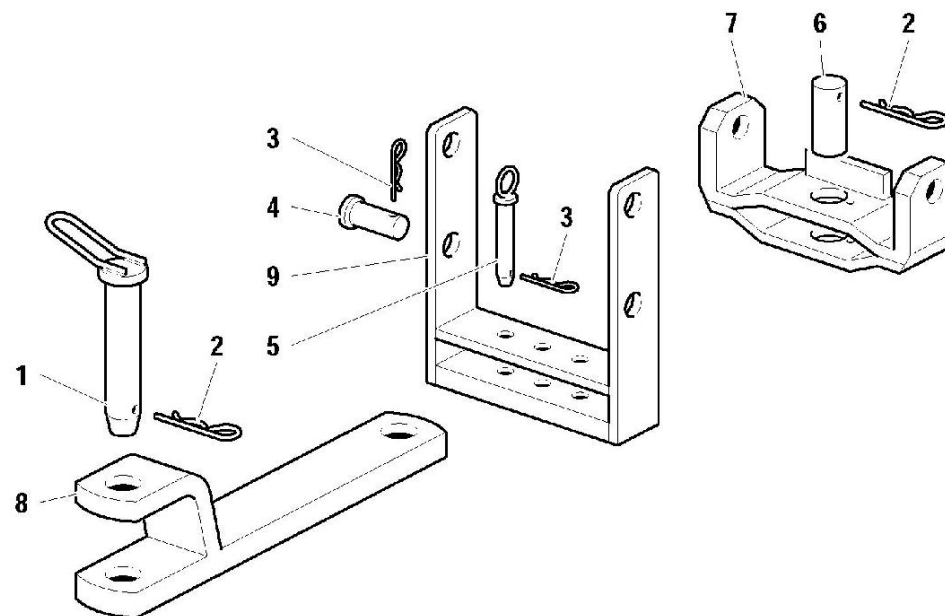

Pos.	Code	Q.ty	Description	Notes
1	56073155	0	PIN	
2	F0851497000	0	SPLIT PIN	
3	F0851486000	0	SPLIT PIN	
4	56372067	0	PIN	
5	56073153	0	INDEXING BOLT	
6	56373502	0	HINGE PIN	
7	59073373	0	RH HINGE	
8	59073151	0	ROD	
9	59073374	0	HOLDER	

RS-M	RS-R	AR-M	AR-R
•	•	•	•

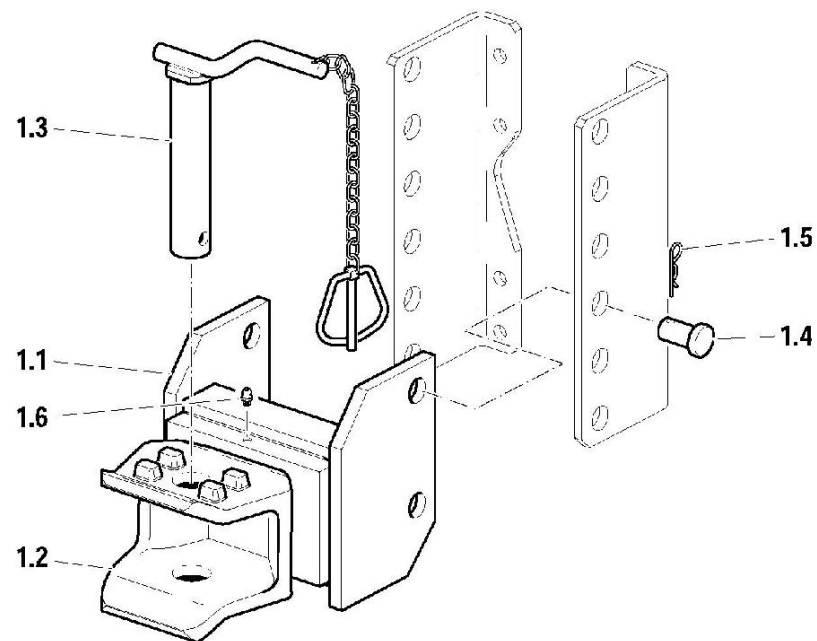
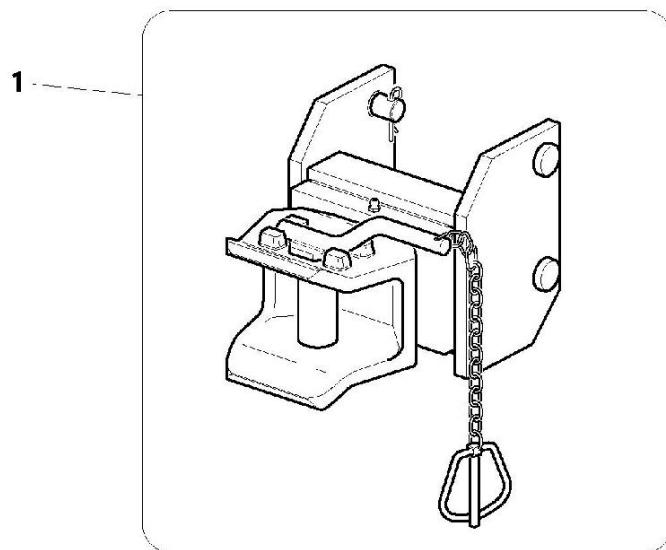

Pos.	Code	Q.ty	Description	Notes
1	59375017	0	TOW HOOK	
1.1	56075018	0	HOOK HINGING GROUP	
1.2	51175011	0	EEC HOMOLOGATED HOOK	
1.3	59075012	0	PIN	
1.4	56377980	1	PIN	
1.5	F0851486000	0	SPLIT PIN	
1.6	F0826056000	0	LUBRICATOR M10 UNI 7663A	



MOTORE "LDW 1503 / B2" - 3 CILINDRI
"LDW 1503 / B2" ENGINE - 3 CYLINDERS
MOTEUR "LDW 1503 / B2" - 3 CYLINDRES
"LDW 1503 / B2" MOTOR - 3 ZYLINDERN
MOTOR "LDW 1503 / B2" - 3 CILINDROS

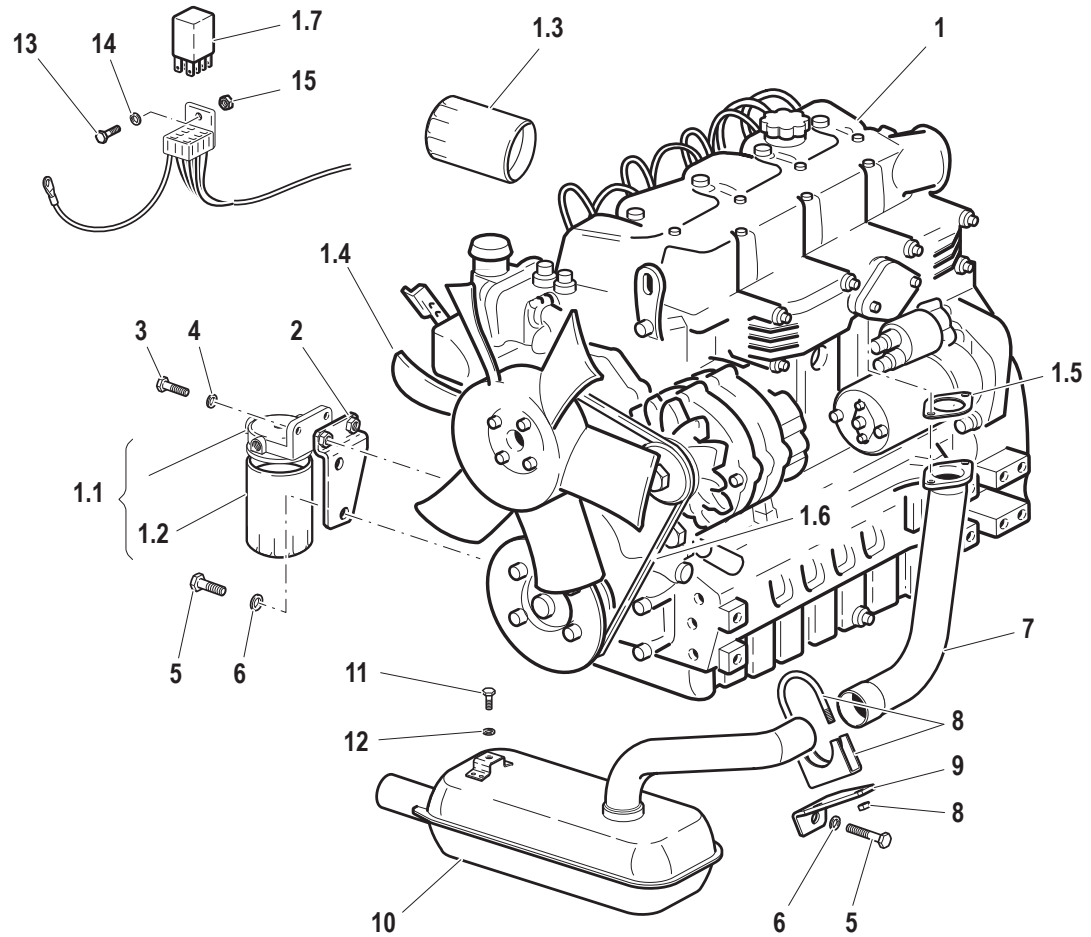

Pos.	Code	Q.ty	Description	Notes
1	41S80000	1	MOT LOMB LDW1503/B2 K2A96C2 *	
1.1	59900192	1	FUEL FILTER	
1.2	59900193	1	FILTER INSERT	
1.3	59900194	1	OIL FILTER	
1.4	58173442	1	FAN	
1.5	F0824812000	1	GASKET	
1.6	59900195	1	ENGINE BELT	
1.7	F0834378001	1	CENTRAL PROCESSING UNIT	
2	59074276	1	FILTER SUPPORT	
3	31112219	1	SCREW TE M10X25 UNI 5739	
4	31411105	1	WASHER 10,5x21	
5	31112270	1	SCREW TE M12X20 UNI 5739	
6	F0843843060	1	WASHER 12	
7	59074278	1	EXHAUST MANIFOLD	
8	58170580	1	COLLAR	
9	56174275	1	FIXING BRACKET	
10	58171761	1	EXHAUST SILENCER	
11	31112148	1	SCREW TE M8X18 UNI 5739 8G	
12	F0843643060	1	WASHER 8	
13	F0861929060	1	SCREW M5X12 UNI 5739	
14	F0843561000	1	WASHER 5	
15	F0814525000	1	NUT M5	

SERIAL
START
904040

ENGINE (40 CV)
Power: 40 CV

CODE REV
A0101_1_63226



MOTORE "LDW 2204 / B1" - 4 CILINDRI
"LDW 2204 / B1" ENGINE - 4 CYLINDERS
MOTEUR "LDW 2204 / B1" - 4 CYLINDRES
"LDW 2204 / B1" MOTOR - 4 ZYLINDERN
MOTOR "LDW 2204 / B1" - 4 CILINDROS

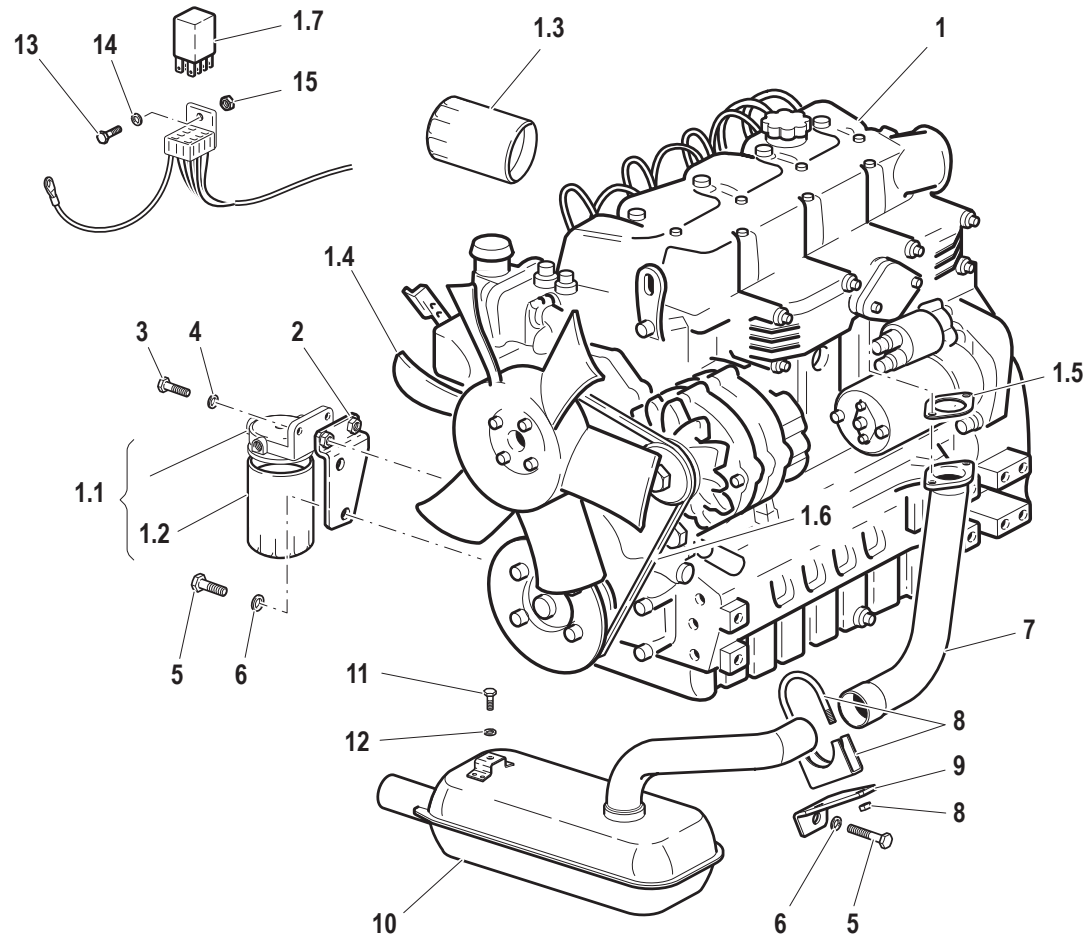

Pos.	Code	Q.ty	Description	Notes
1	41S90000	1	MOT LOMB LDW2204/B1 K2B24C1 *	
1.1	59900192	1	FUEL FILTER	
1.2	59900193	1	FILTER INSERT	
1.3	59900194	1	OIL FILTER	
1.4	58173442	1	FAN	
1.5	F0824812000	1	GASKET	
1.6	59900196	1	ENGINE BELT	
1.7	F0834378001	1	CENTRAL PROCESSING UNIT	
2	59074276	1	FILTER SUPPORT	
3	31112219	1	SCREW TE M10X25 UNI 5739	
4	31411105	1	WASHER 10,5x21	
5	31112270	1	SCREW TE M12X20 UNI 5739	
6	F0843843060	1	WASHER 12	
7	59074277	1	EXHAUST MANIFOLD	
8	58170580	1	COLLAR	
9	56174275	1	FIXING BRACKET	
10	58171761	1	EXHAUST SILENCER	
11	31112148	1	SCREW TE M8X18 UNI 5739 8G	
12	F0843643060	1	WASHER 8	
13	F0861929060	1	SCREW M5X12 UNI 5739	
14	F0843561000	1	WASHER 5	
15	F0814525000	1	NUT M5	

SERIAL
START
904040

ENGINE (50 CV)

Power: 50 CV

CODE REV

A0102_1_63249

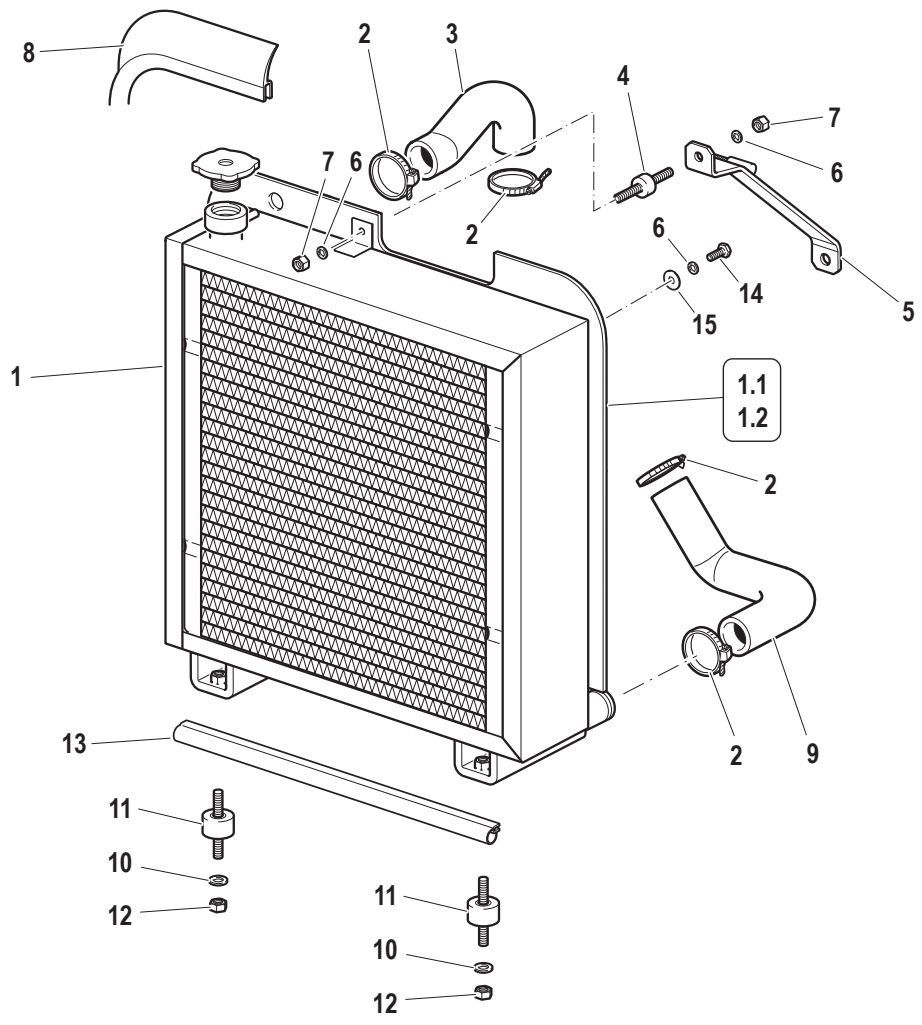

(A.02.011)

Pos.	Code	Q.ty	Description	Notes
1	58178703	1	RADIATOR	
1.1	58176290	1	DUCT	
1.2	58178731	1	DUCT	
2	F0817535000	1	CLAMP	
3	55171747	1	SLEEVE	
4	F0849206005	1	SILENT-BLOCK	
5	59074274	1	BRACKET	
6	F0843570000	1	WASHER 6	
7	31211060	1	NUT M6	
8	F0256809050	1	GASKET	
9	55171748	1	SLEEVE	
10	F0843755000	1	WASHER 10	
11	58174356	1	SILENT-BLOCK	
12	31211100	1	NUT M10	
13	28174882	1	GASKET	
14	31111091	1	SCREW E M6X14 UNI 5739 8G	
15	31411066	1	WASHER 6,6x18	

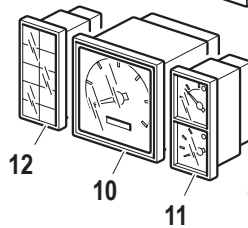
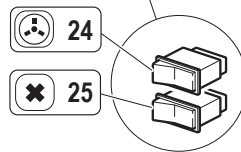
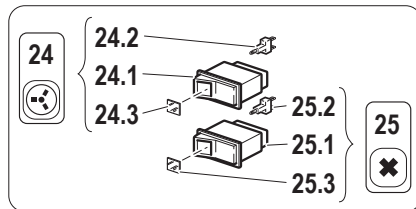
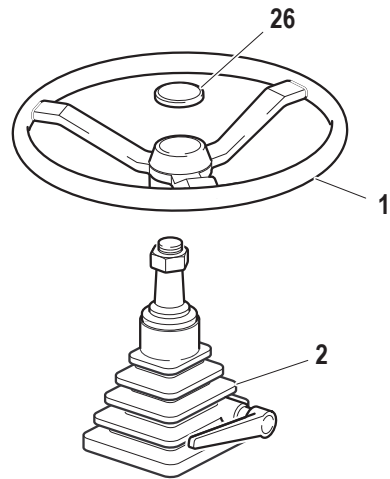

 - PRESA DI FORZA CON FRIZIONE INDIPENDENTE
 - POWER TAKE-OFF WITH INDEPENDENT CLUTCH
 - PRISE DE FORCE AVEC EMBRAYAGE INDEPEND.
 - ZAPFWELLE MIT UNABHÄNGIGER KUPPLUNG
 - TOMA DE FUERZA CON EMBRAGUE INDEPEND.

 - DIFFERENZIALE CON BLOCCAGGIO ELETTROIDRAUL.
 - DIFFERENTIAL WITH ELECTROHYDRAULIC LOCKING
 - DIFFERENTIEL AVEC BLOCAGE ÉLECTROHYDR.
 - DIFFERENTIAL MIT ELEKTROHYDR. SPERRE
 - DIFERENCIAL CON BLOQUEO ELECTROHIDRÁULICO

615074

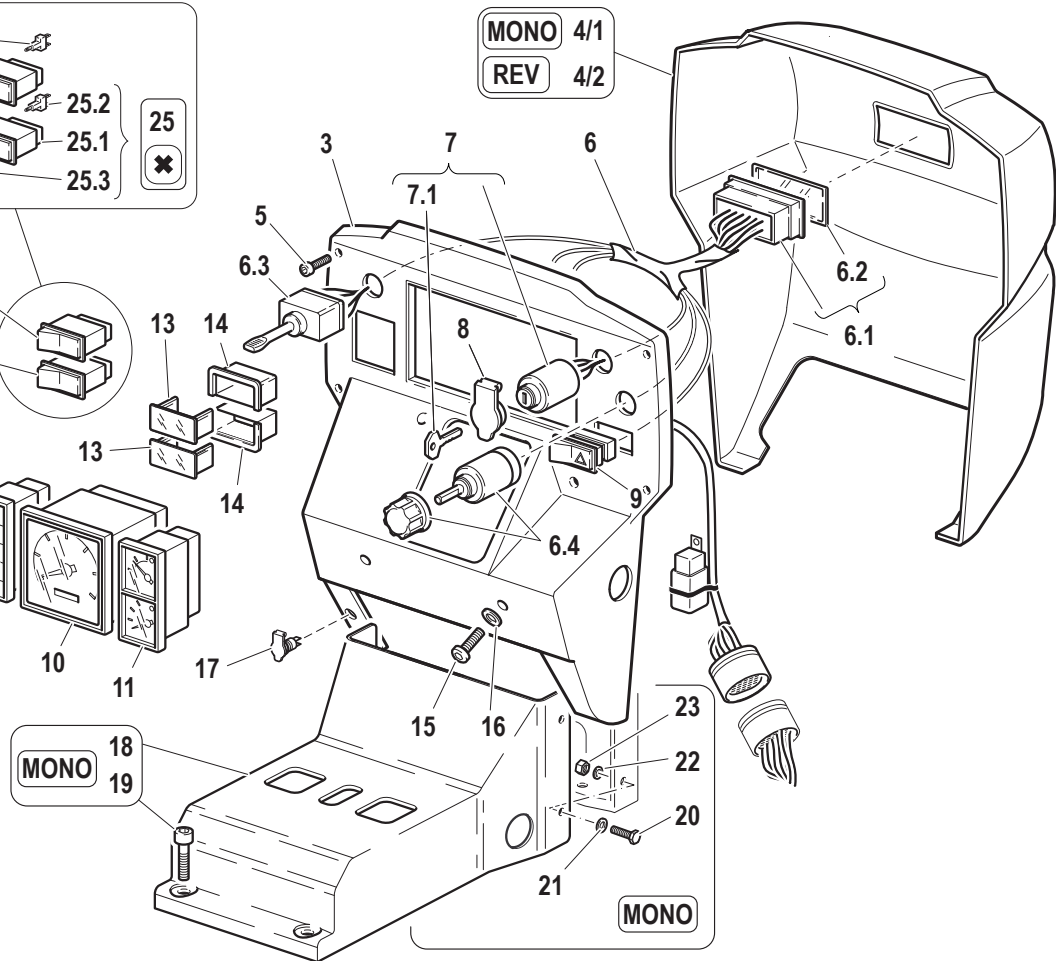

Pos.	Code	Q.ty	Description	Notes
1	F0865040000	1	STEERING WHEEL	
2	581A0379	1	UNIT	
3	55274441	1	INSTRUMENT PANEL	
4/1	55271852	1	INSTRUMENT PANEL	
4/2	55271644	1	INSTRUMENT PANEL	
5	31510053	1	RIBBED SCREW TC 4,8X32	
6	58075777	1	CABLE	
6.1	58170453	1	FUSE BOX	
6.2	58172267	1	COVER	
6.3	F0825436000	1	SWITCH	
6.4	F0825436003	1	SWITCH	
7	30000614	1	PANEL	
7.1	58045806	1	KEY	
8	F0825400060	1	COVER	
9	F0825115010	1	PUSH-BUTTON	
10	58175771	1	TRACTOR METER	
11	58175769	1	DIGITAL INSTRUMENT	
12	58175770	1	WARNING LIGHT HOLDER	
13	58172043	1	FRONT GRILLE	
14	58170376	1	TERMINAL FOR SWITCH	
15	F0862479020	1	SCREW M8X16 7380	
16	31411084	1	WASHER 8,4x17	
17	F0825403050	1	SOCKET	
18	57374195	1	COVER	
19	F0863114000	1	SCREW M10X12 UNI 5931	
20	31112090	1	SCREW TE M6X16 UNI 5739 8G	
21	F0843605010	1	WASHER 6	
22	F0843570000	1	WASHER 6	
23	31211060	1	NUT M6	
24	58170344	1	CHANGE-OVER SWITCH	
24.1	58173116	1	CHANGE-OVER SWITCH	
24.2	58173119	1	LAMP	
24.3	58173120	1	GLASS	
25	58170345	1	CHANGE-OVER SWITCH	

SERIAL
START
902634

DASHBOARD AND STEERING WHEEL

CODE REV

B0501_1_42781

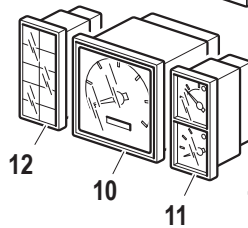
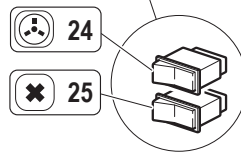
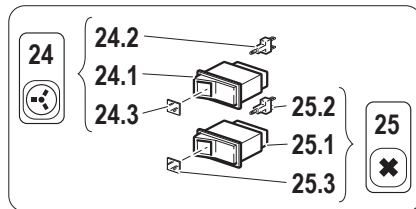
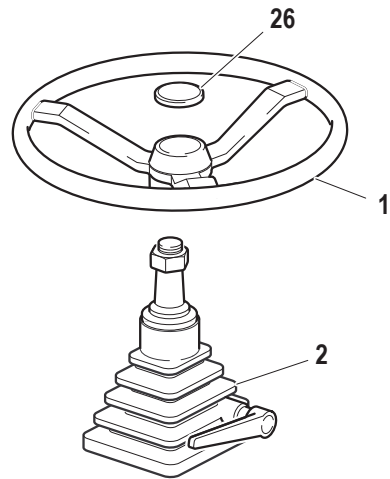



 - PRESA DI FORZA CON FRIZIONE INDIPENDENTE
 - POWER TAKE-OFF WITH INDEPENDENT CLUTCH
 - PRISE DE FORCE AVEC EMBRAYAGE INDEPEND.
 - ZAPFWELLE MIT UNABHÄNGIGER KUPPLUNG
 - TOMA DE FUERZA CON EMBRAGUE INDEPEND.

 - DIFFERENZIALE CON BLOCCAGGIO ELETTROIDRAUL.
 - DIFFERENTIAL WITH ELECTROHYDRAULIC LOCKING
 - DIFFERENTIEL AVEC BLOCAGE ÉLECTROHYDR.
 - DIFFERENTIAL MIT ELEKTROHYDR. SPERRE
 - DIFERENCIAL CON BLOQUEO ELECTROHIDRÁULICO

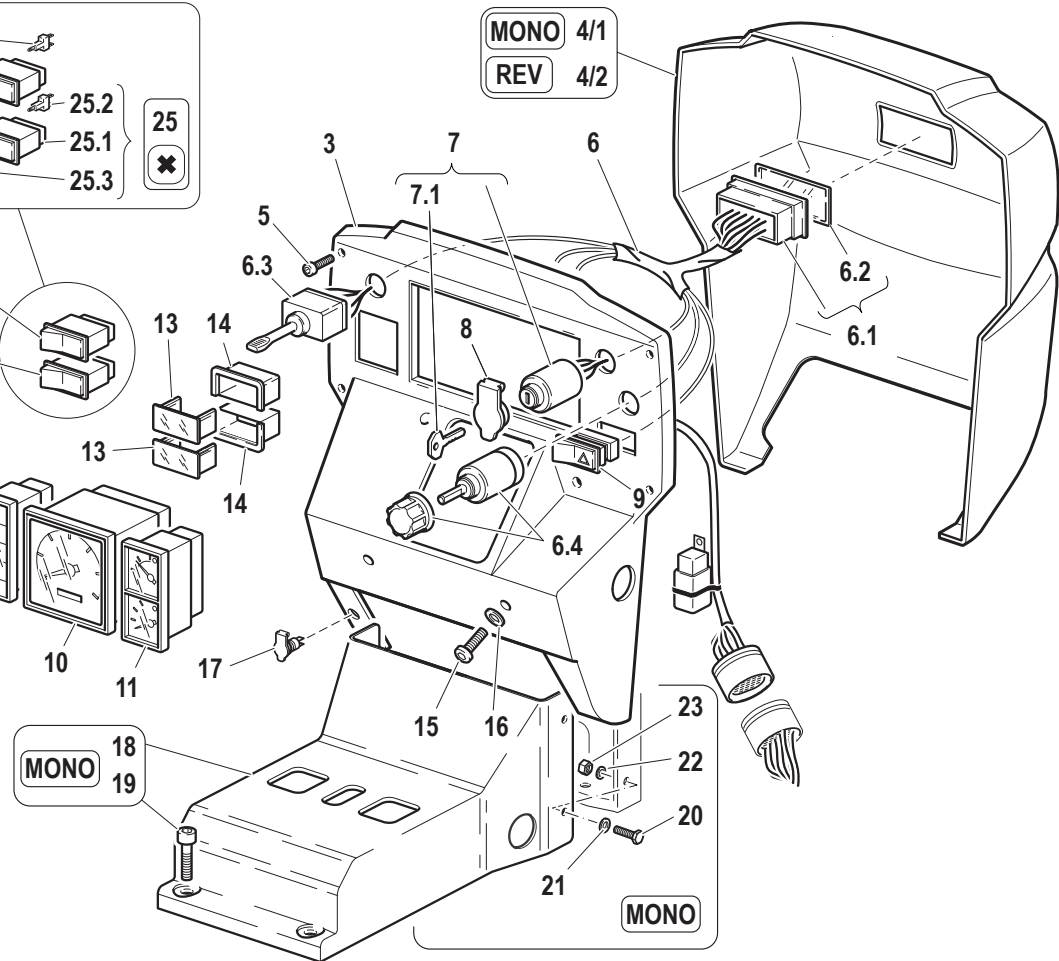
6150714

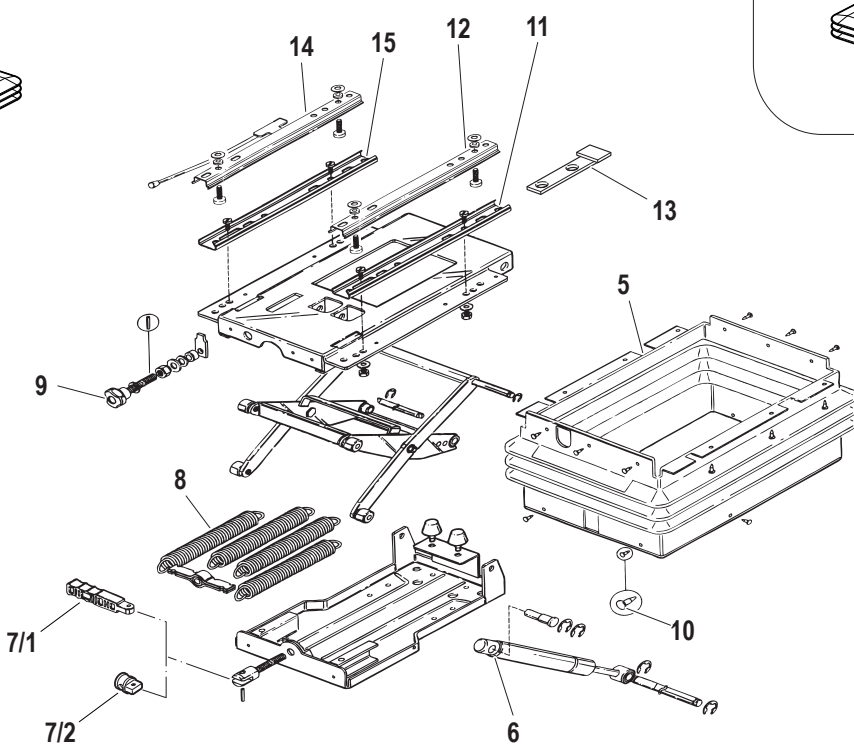
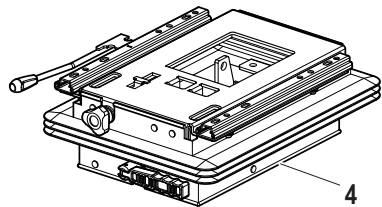
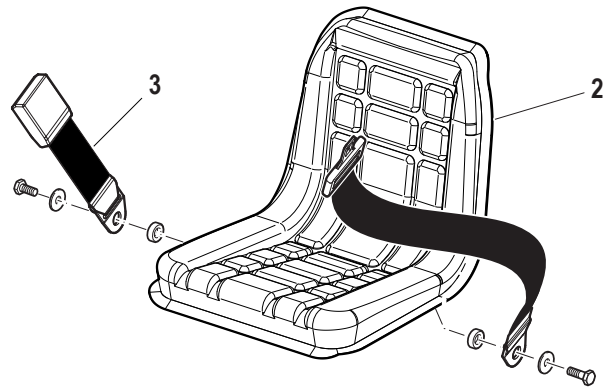

Pos.	Code	Q.ty	Description	Notes
25.1	58173116	1	CHANGE-OVER SWITCH	
25.2	58173119	1	LAMP	
25.3	58173121	1	GLASS	
26	F0865040010	1	PLUG	



B.06.02-0

Pos.	Code	Q.ty	Description	Notes
1	58177722	1	SEAT	
2	59901050	1	SEAT	
3	58192377	1	SAFETY BELT	
4	59901049	1	SUSPENSION	
5	59900159	1	BELLOWS	
6	59900156	1	SHOCKS ABSORBER	
7/1	59900155	1	LEVER	
7/2	56172172	1	SMALL BLOCK	
8	59900154	4	SPRING	
9	59900153	1	KNOB	
10	59900158	18	SCREW	
11	59900157	1	LOWER GUIDE	
12	59900160	1	GUIDE	
13	59071241	1	STOP PLATE	
14	59900161	1	GUIDE	
15	59900152	1	LOWER GUIDE	

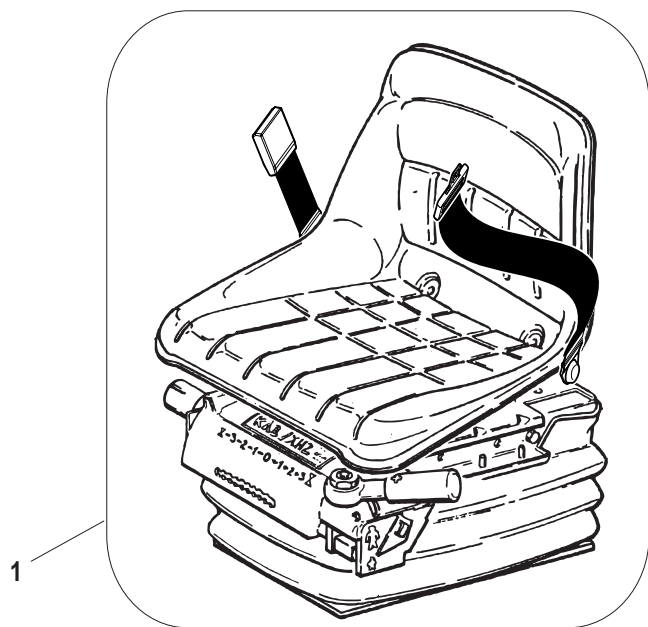

B.06.04-0

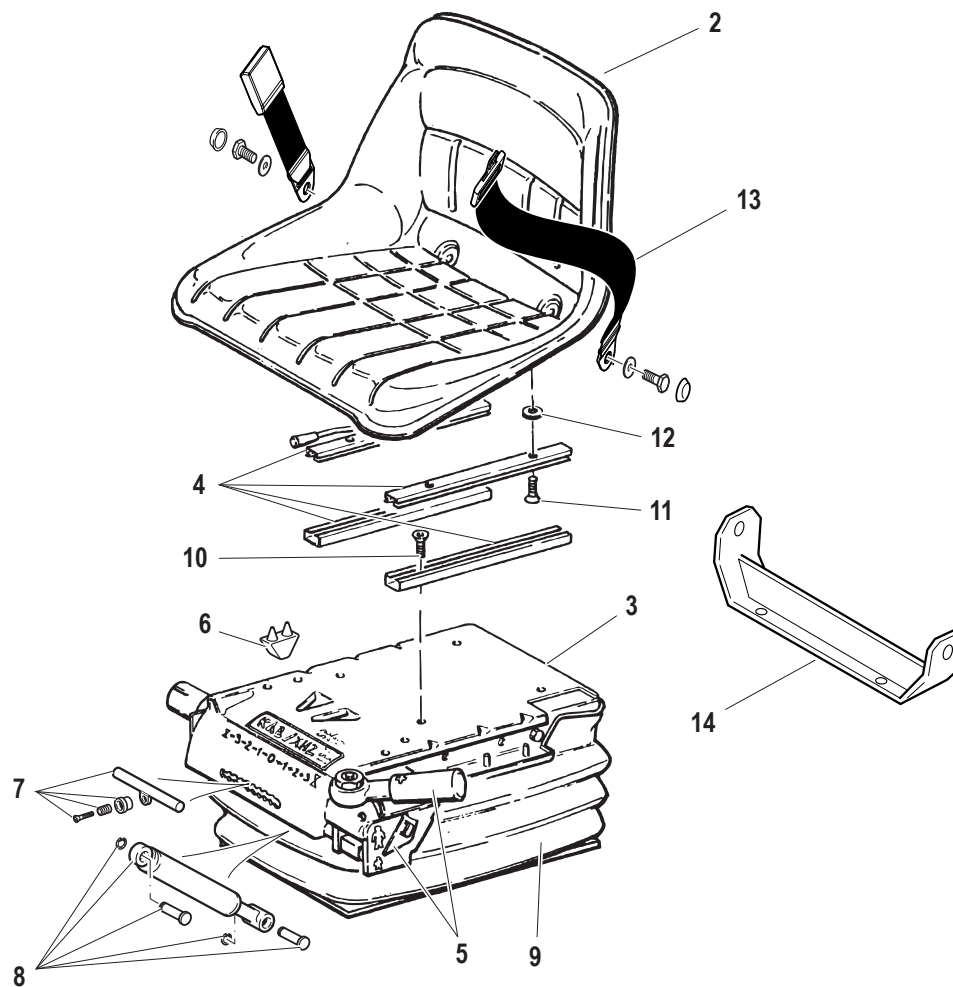

Pos.	Code	Q.ty	Description	Notes
1	59900199	1	SEAT	
2	F0150036216	1	SEAT CAVITY	
3	F0150036219	1	SPRING	
4	58173437	1	SEAT GUIDE	
5	59900183	1	CONTROL	
6	59900184	1	SPRINGS LIMITER	
7	59900185	1	CONTROL	
8	59900186	1	SHOCKS ABSORBER	
9	59900187	1	BELLOWS	
10	31111151	5	SCREW TE M8X16 UNI 5739 8G	
11	F0862495010	4	SCREW M8X16 UNI 5931	
12	F0843696000	6	WASHER D.24x8/6	
13	58192377	1	SAFETY BELT	
14	56178591	1	BRACKET	

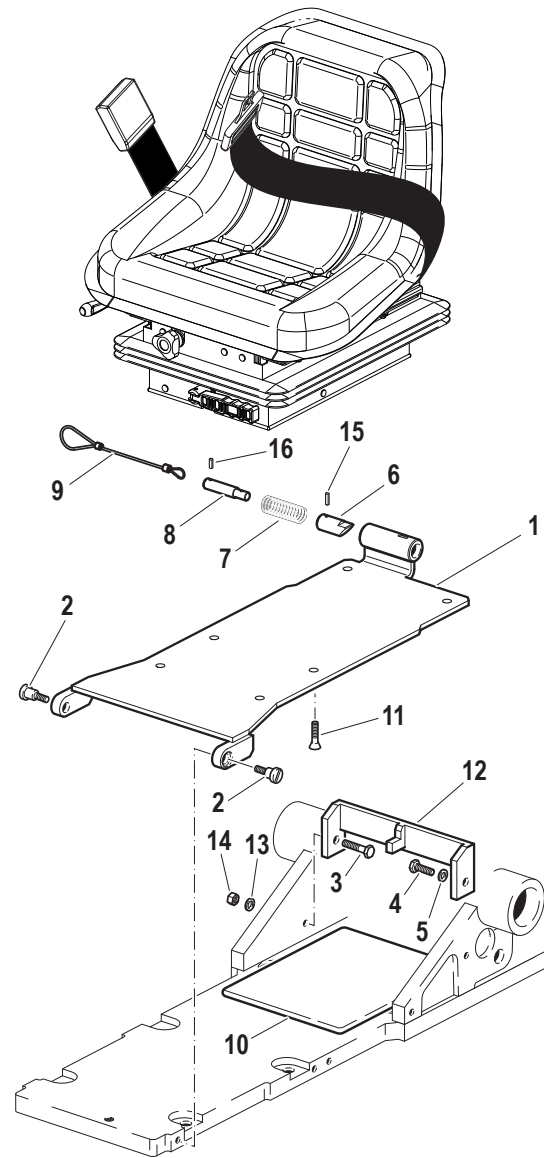

Pos.	Code	Q.ty	Description	Notes
1	590A0695	1	FIXING PLATE	
2	56375436	1	HINGE PIN	
3	31112155	1	SCREW TE M8X45 UNI 5739 8G	
4	31112151	1	SCREW TE M8X25 UNI 5739 8G	
5	31411084	1	WASHER 8,4x17	
6	56374460	1	LOCKING BOLT	
7	58070390	1	SEAT SPRINGS	
8	561A0764	1	PISTON	
9	553A0763	1	CABLE	
10	57370321	1	RUBBER	
11	F0862481000	1	SCREW M8x16 UNI 5933	
12	590A0698	1	BRACKET	
13	F0843643060	1	WASHER 8	
14	31221080	1	NUT M8	
15	34211028	1	ROLL PIN	
16	34211027	1	ROLL PIN	

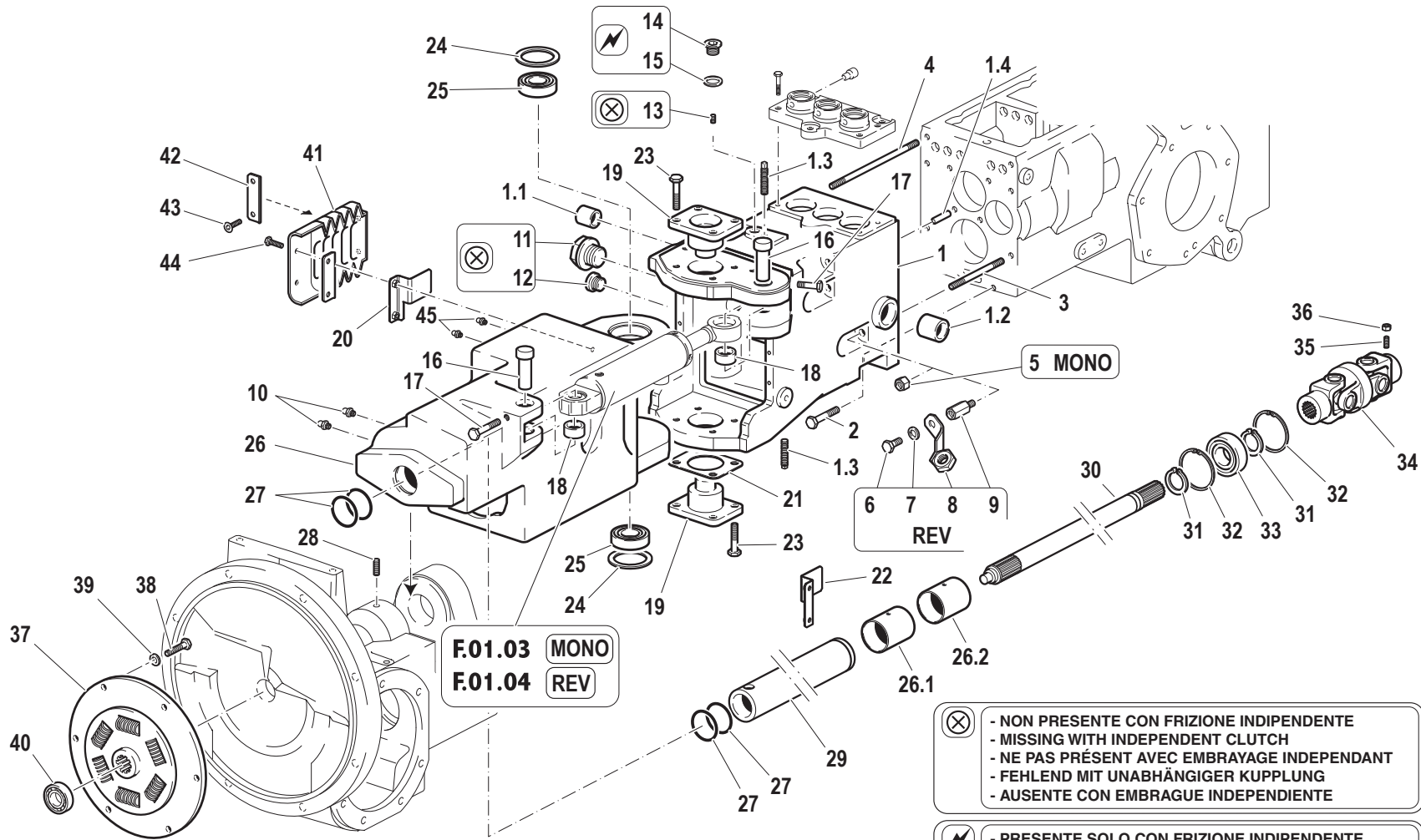

F.01.03 MONO
 F.01.04 REV

5 MONO

6 7 8 9
 REV

⊗ - NON PRESENTE CON FRIZIONE INDIPENDENTE
 - MISSING WITH INDEPENDENT CLUTCH
 - NE PAS PRÉSENT AVEC EMBRAYAGE INDEPENDANT
 - FEHLEND MIT UNABHÄNGIGER KUPPLUNG
 - AUSENTE CON EMBRAGUE INDEPENDIENTE

⚡ - PRESENTE SOLO CON FRIZIONE INDIPENDENTE
 - ONLY WITH INDEPENDENT CLUTCH
 - SEULEMENT AVEC EMBRAYAGE INDEPENDANT
 - NUR MIT UNABHÄNGIGER KUPPLUNG
 - PRESENTE SOLO CON EMBRAGUE INDEPENDIENTE

Pos.	Code	Q.ty	Description	Notes
1	59274025	1	CLUTCH HOUSING	
1.1	58071794	1	BUSHING	
1.2	58071793	1	BUSHING	
1.3	58070743	1	PLUG	
1.4	56370228	1	CYLINDRICAL PLUG	
2	F0863359000	1	SCREW M10X40 UNI 5737	
3	F0838475000	1	STUD BOLT M10X90 UNI 5911 8.8	
4	F0838535050	1	STUD BOLT M10X170 UNI5911	
5	F0814647000	1	NUT M10	
6	31112208	1	SCREW TE M10X16 UNI 5739	
7	F0843755000	1	WASHER 10	
8	59076058	1	SUPPORTING YOKE	
9	F0814621000	1	SMALL COLUMN CH.17xM10/29	
10	F0826056000	1	LUBRICATOR M10 UNI 7663A	
11	58072046	1	PLUG	
12	58072045	1	PLUG	
13	F0863105000	1	SCREW M10X10 UNI 5923	
14	F0852578050	1	PLUG	
15	F0824110000	1	COPPER WASHER 3/8 GAS	
16	56373542	1	HINGE PIN	
17	56370178	1	SCREW	
18	56170226	1	SPACER	
19	523A0166	1	JOINT PIN	
20	59075711	1	PLATE	
21	52172158	1	SHIM	
21	52172159	1	SHIM	
21	52172160	1	SHIM	
21	52172161	1	SHIM	
21	52172162	1	SHIM	
22	59075712	1	FIXING PLATE	
23	F0863267050	1	SCREW M10x25	
24	58170077	1	GASKET	
25	F0812747000	1	BEARING 32006X (30x55x17)	
26	59279819	1	BOX	

SERIAL
START
915538

INTERMEDIATE SECTION

CODE REV
C0202_2_64535

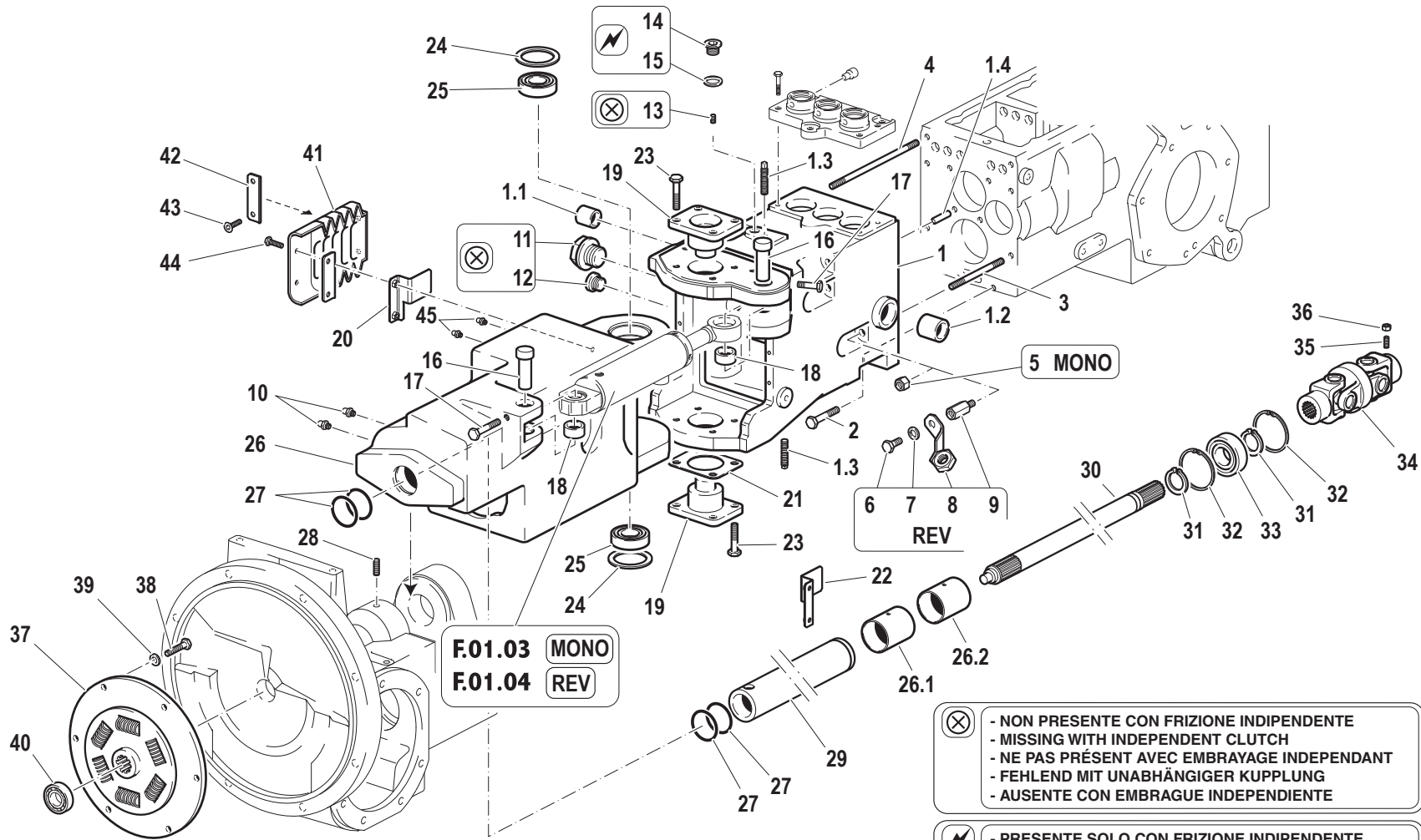

F.01.03 MONO
F.01.04 REV

5 MONO

6 REV

⊗ - NON PRESENTE CON FRIZIONE INDIPENDENTE
- MISSING WITH INDEPENDENT CLUTCH
- NE PAS PRÉSENT AVEC EMBRAYAGE INDEPENDANT
- FEHLEND MIT UNABHÄNGIGER KUPPLUNG
- AUSENTE CON EMBRAGUE INDEPENDIENTE

⚡ - PRESENTE SOLO CON FRIZIONE INDIPENDENTE
- ONLY WITH INDEPENDENT CLUTCH
- SEULEMENT AVEC EMBRAYAGE INDEPENDANT
- NUR MIT UNABHÄNGIGER KUPPLUNG
- PRESENTE SOLO CON EMBRAGUE INDEPENDIENTE

Pos.	Code	Q.ty	Description	Notes
26.1	56276360	1	BUSHING	
26.2	56276359	1	BUSHING	
27	38104412	1	O-RING 3175 (44,12X2,62)	
28	58170013	1	SCREW	
29	56471645	1	PIN	
30	56572156	1	FRONT CLUTCH SHAFT	
31	35121025	1	SEEGER RING E 25 DIN 471	
32	35111052	1	SEEGER RING I 52 DIN 472	
33	37112249	1	BEARING	
34	58172155	1	CARDAN JOINT	
35	F0862593050	1	SCREW M8X20 UNI 5927	
36	F0814574000	1	NUT M8	
37	58173493	1	JOINT	
38	31112150	1	SCREW TE M8X20 UNI 5739 8G	
39	31421083	1	WASHER	
40	37112120	1	BEARING	
41	55172608	1	BELLOWS	
42	56172163	1	FIXING BRACKET	
43	31132562	1	SCREW TSVEI M6X16 UNI 5933	
44	F0862210000	1	SCREW M6X25 UNI 5737	
45	30000007	1	LUBRICATOR	

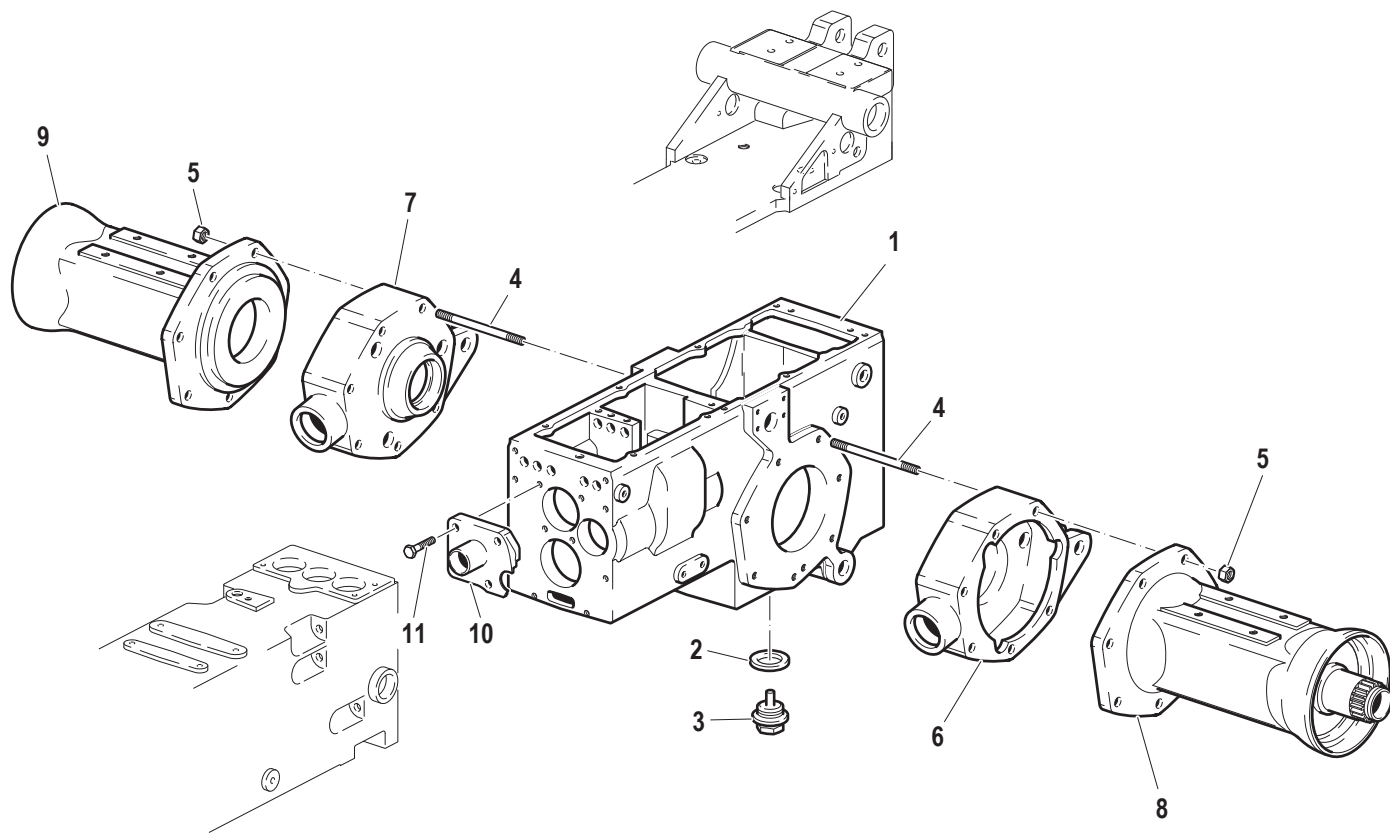

Pos.	Code	Q.ty	Description	Notes
1	511A0898	1	DRIVE HOUSING	
2	31480191	1	COPPER WASHER 30x36/1,5	
3	581A0108	1	PLUG	
4	F0838660000	1	STUD BOLT M12X105 UNI 5911-66	
5	F0814695000	1	NUT M12	
6	51171603	1	BRAKE HOUSING	
7	51171604	1	BRAKE HOUSING	
8	51276978	1	REDUCTION BOX	
9	51276979	1	REAR AXLE HOUSING	
10	590A0885	1	FRONT COVER	
11	31112219	1	SCREW TE M10X25 UNI 5739	

SERIAL
START
920224

REAR AXLE

CODE REV
C0302_1_72740

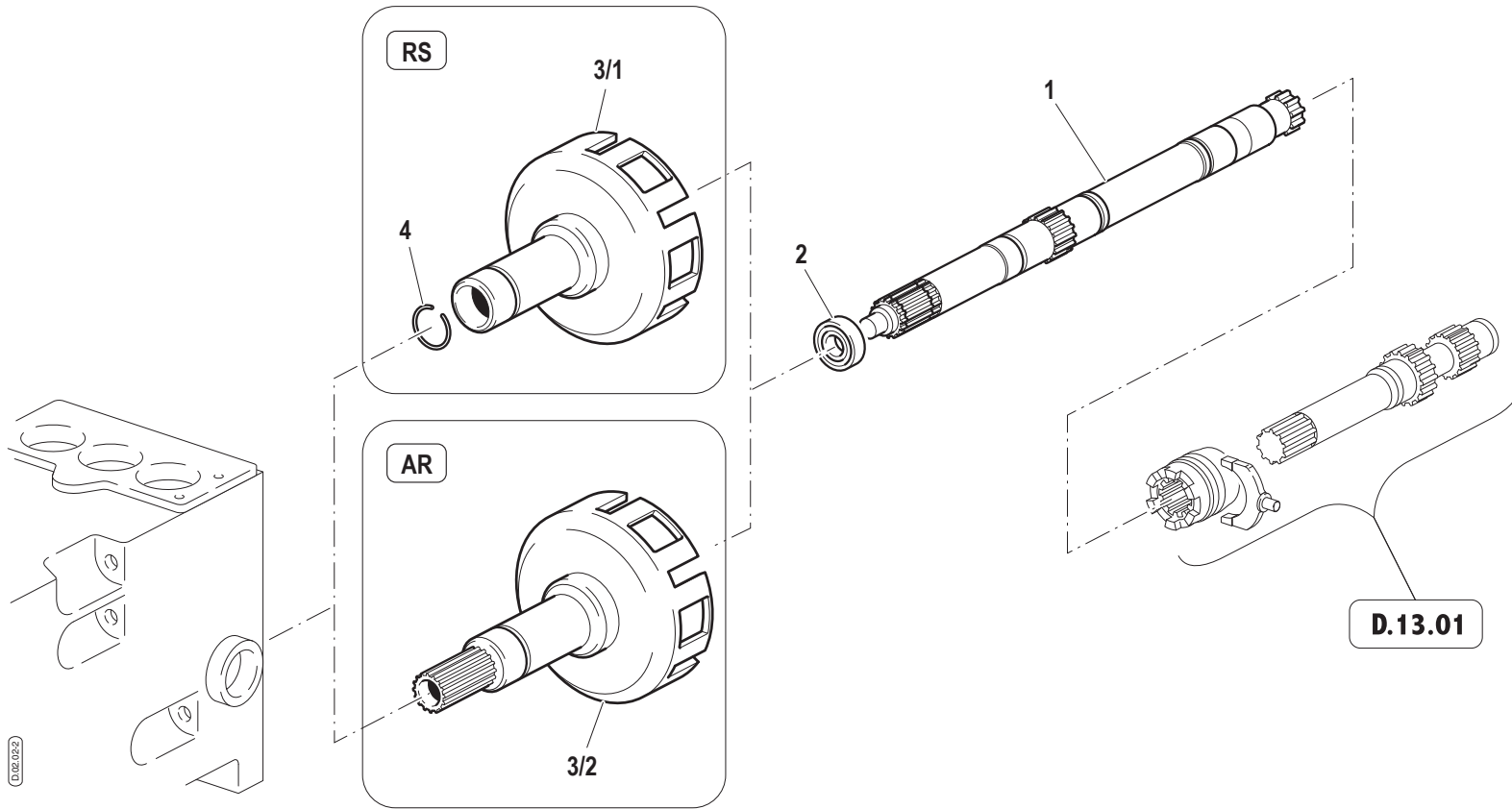

Pos.	Code	Q.ty	Description	Notes
1	524A0886	1	ALB.ENTR.CAMBIO 40-50L MONO **	
2	37111151	1	BEARING	
3/1	52572460	1	CLUTCH HOUSING	
3/2	52572486	1	CLUTCH HOUSING	
4	F0800056050	1	CIRCLIP B28 UNI 7433	

SERIAL
START
920224

CLUTCH/INPUT SHAFT : STANDARD CLUTCH

CODE REV
D0202_2_72891

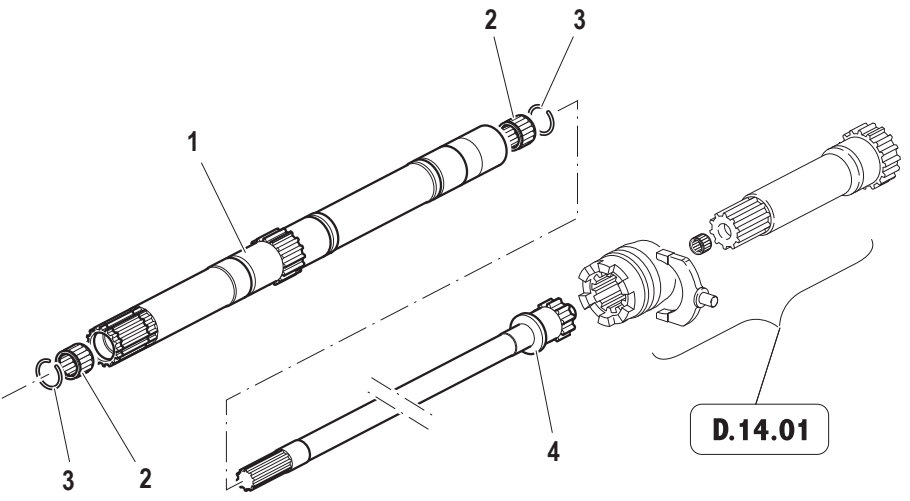
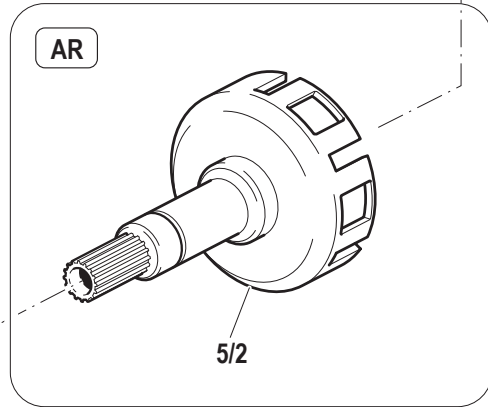
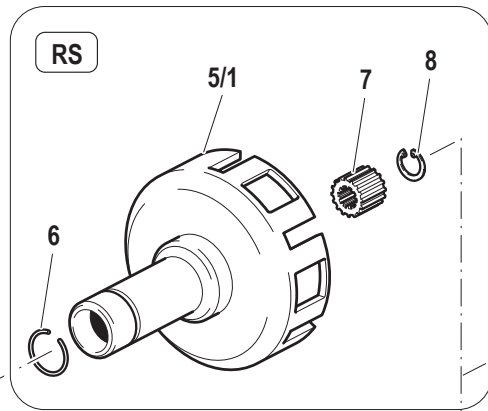
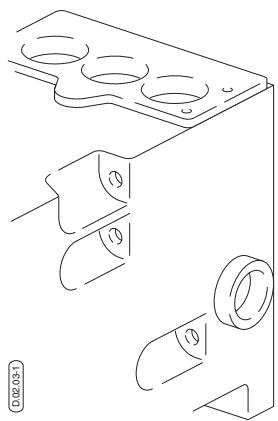

Pos.	Code	Q.ty	Description	Notes
1	52476391	1	SHAFT	
2	F0812578050	1	ROLLER CAGE 17x21/13	
3	F0801156050	1	SAFETY RING	
4	56472363	1	SHAFT	
5/1	52571740	1	CLUTCH HOUSING	
5/2	59272488	1	CLUTCH HOUSING	
6	F0800056050	1	CIRCLIP B28 UNI 7433	
7	52472344	1	FIX SLEEVE	
8	35111027	1	SEEGER RING I 27 DIN 472	

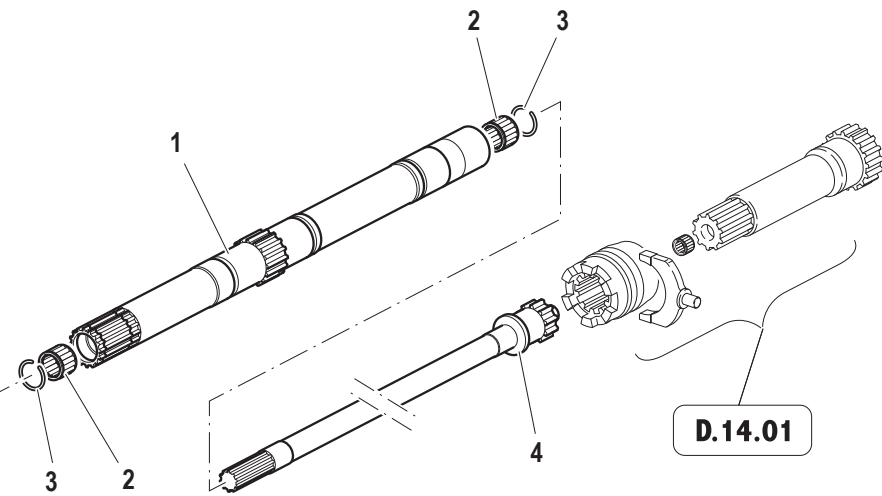
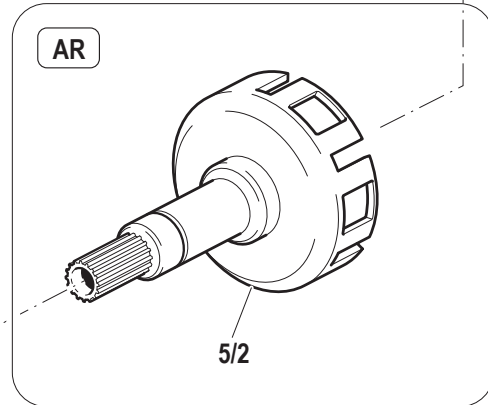
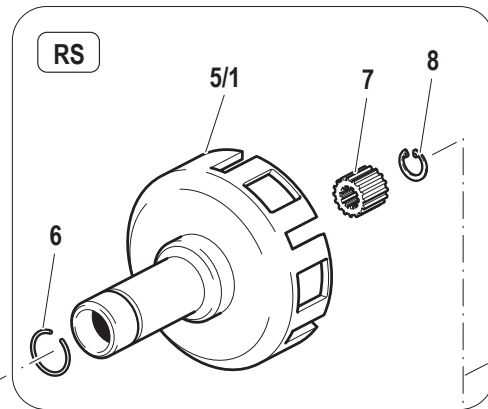
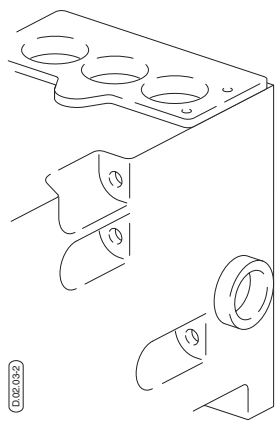

Pos.	Code	Q.ty	Description	Notes
1	524A0887	1	SHAFT	
2	F0812578050	1	ROLLER CAGE 17x21/13	
3	F0801156050	1	SAFETY RING	
4	56472363	1	SHAFT	
5/1	52571740	1	CLUTCH HOUSING	
5/2	59272488	1	CLUTCH HOUSING	
6	F0800056050	1	CIRCLIP B28 UNI 7433	
7	52472344	1	FIX SLEEVE	
8	35111027	1	SEEGER RING I 27 DIN 472	

SERIAL
START
920224

CLUTCH/INPUT SHAFT : POWER TAKE-OFF WITH INDEPENDENT

CODE REV
D0203_2_72897

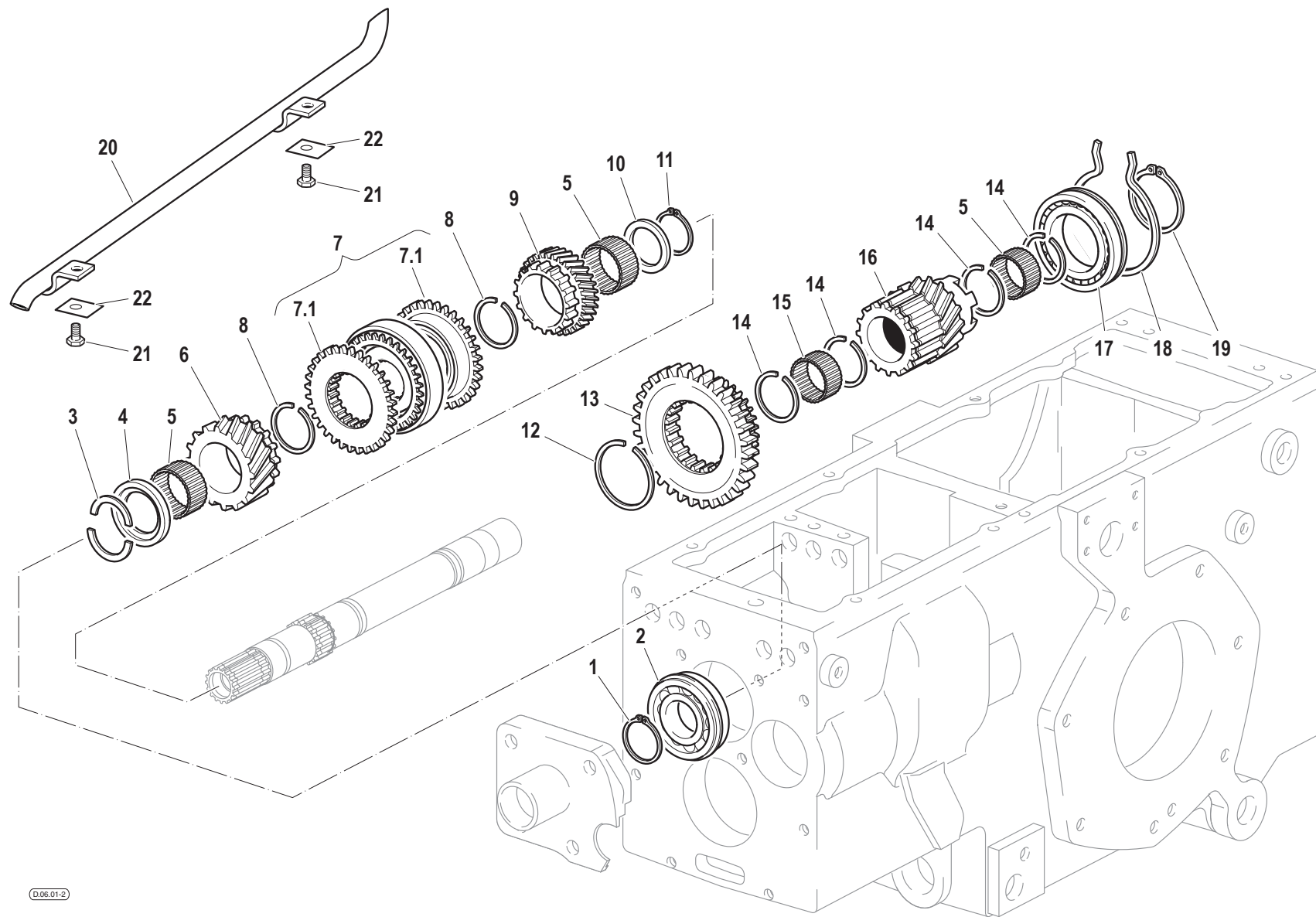

Pos.	Code	Q.ty	Description	Notes
1	F0801241010	1	SEEGER RING E 30 UNI 7436	
2	F0812750000	1	BEARING 6206-NR (30X62/16)	
3	56371440	2	HALF RING	
4	56471441	1	SHIM	
5	F0812737000	3	ROLLER CAGE K 30X35/27	
6	52479154	1	SPEED GEAR	
7	58179928	1	LOCK SYNCHRONIZER	
7.1	52475921	2	RING	
8	F0801266050	2	SAFETY RING	
9	52479155	1	SPEED GEAR	
10	56471654	1	SHIM	
11	35121030	1	SEEGER RING E 30 DIN 471	
12	F0801346200	4	SAFETY RING	
13	52479156	1	SLIDING GEAR	
14	F0801266000	4	SAFETY RING	
15	F0812736010	1	ROLLER CAGE K 30X35/20 H	
16	52479158	1	CONDUCTOR GEAR	
17	50974166	1	BEARING	
18	58073788	1	SEEGER RING	
19	F0801331050	1	SEEGER RING E 45 UNI 7436	
20	59079728	1	TUBO LUBR.INVER.SINCR(A2346) *	
21	31112082	3	SCREW TE M6X12 UNI 5739 8G	
22	31450060	3	SMALL PLATE	

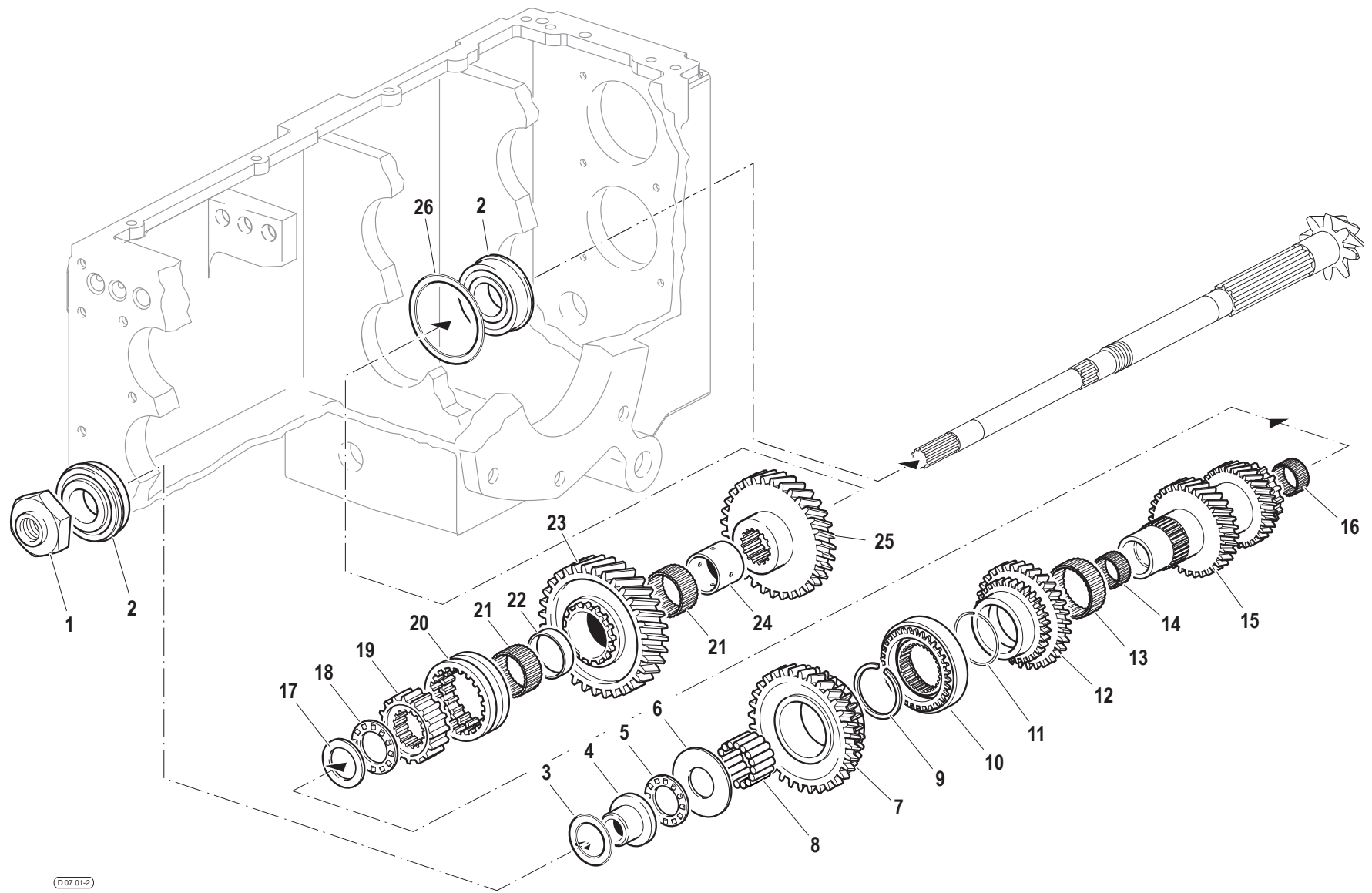

Pos.	Code	Q.ty	Description	Notes
1	56371652	1	NUT	
2	581A0460	2	BEARING	
3	58024193	1	SHIM	
3	58024194	1	SHIM	
3	58024195	1	SHIM	
3	58024196	1	SHIM	
3	58074109	1	SHIM	
4	56471655	1	BUSHING	
5	58173790	1	BEARING	
6	52473789	1	THRUST PLATE	
6	52473812	1	THRUST PLATE	
6	52473813	1	THRUST PLATE	
7	52479163	1	DRIVEN GEAR	
8	58179262	1	ROLLER BEARING (4x19,8)	
9	F0801280100	1	SAFETY RING	
10	58175937	1	LOCK SYNCHRONIZER	
11	58072505	1	SHOULDERED WASHER	
12	52479164	1	DRIVEN GEAR	
13	F0812918050	1	ROLLER CAGE K 42X47/17	
14	F0812686100	1	ROLLER CAGE K 25X30X24 H	
15	52479162	1	DOUBLE GEAR	
16	F0812732080	1	ROLLER CAGE 27X34/17 H	
17	52473796	1	THRUST PLATE	
18	58173797	1	BEARING	
19	52473721	1	SLEEVE	
20	52471459	1	SLIDING SLEEVE	
21	F0812871030	2	ROLLER CAGE K 37X42/17	
22	56271457	1	SPACER	
23	52479160	1	DOUBLE GEAR	
24	56471461	1	BUSHING	
25	52479157	1	SPEED GEAR	
26	56371661	1	ADJUSTING RING	
26	56371662	1	ADJUSTING RING	
26	56371663	1	ADJUSTING RING	

SERIAL
START
920224

SECONDARY SHAFT GEARS

CODE REV
D0701_2_72962

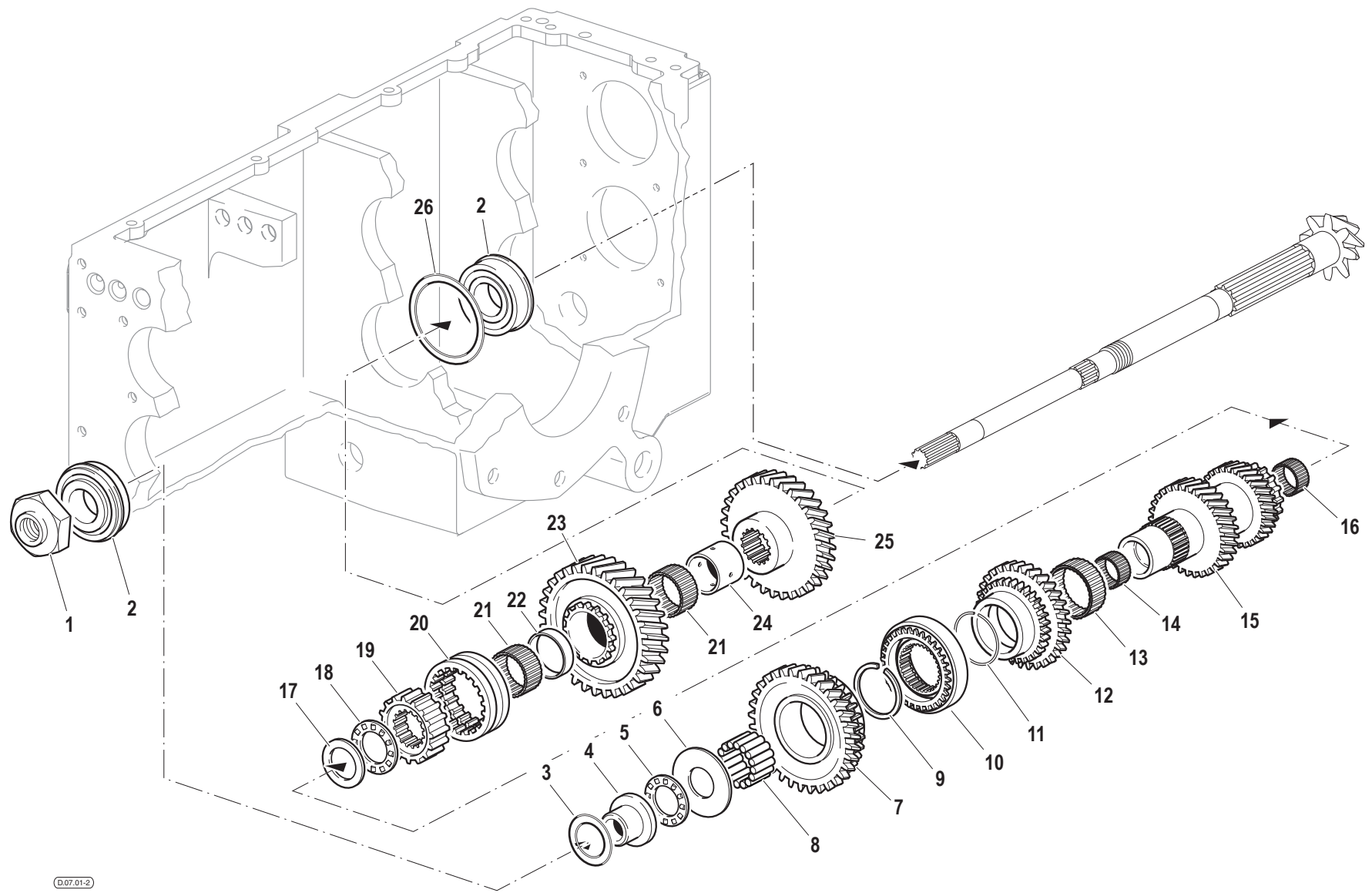

Pos.	Code	Q.ty	Description	Notes
26	56371664	1	ADJUSTING RING	
26	56373440	1	ADJUSTING RING	

SERIAL
START
920224

SECONDARY SHAFT GEARS

CODE REV
D0701_2_72962

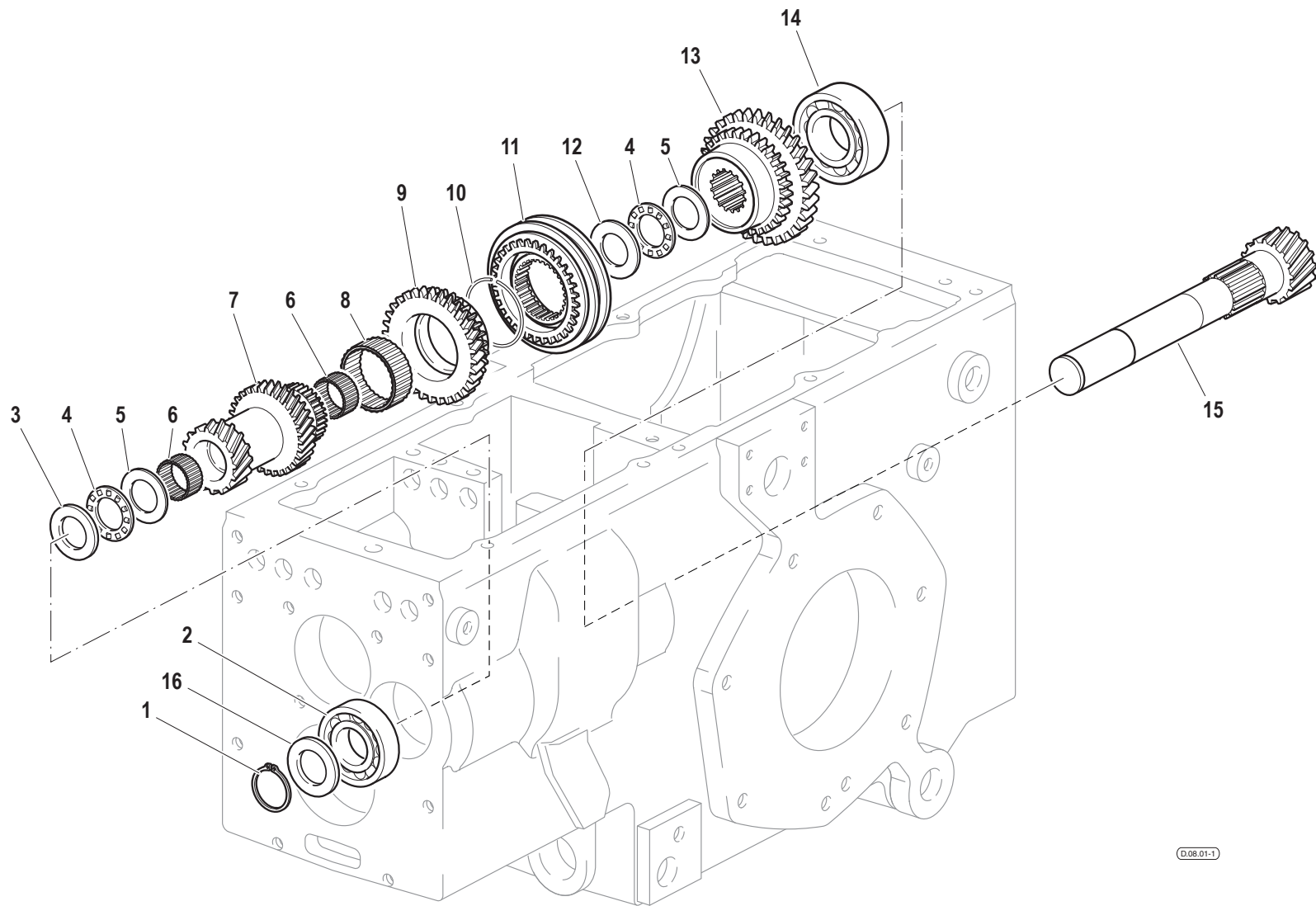

Pos.	Code	Q.ty	Description	Notes
1	35131026	1	SEEGER RING E 25X2 UNI 7436	
2	37111255	1	BEARING	
3	52477987	1	THRUST PLATE	
3	52473791	1	THRUST PLATE	
3	52473815	1	THRUST PLATE	
3	52474239	1	THRUST PLATE	
4	58173790	1	BEARING	
5	58173792	1	THRUST PLATE	
6	F0812689000	2	ROLLER CAGE K 25X30/20 H	
7	52479153	1	CONDUCTOR GEAR	
8	F0812918050	1	ROLLER CAGE K 42X47/17	
9	52479165	1	CONDUCTOR GEAR	
10	58072505	1	SHOULDERED WASHER	
11	58172571	1	LOCK SYNCHRONIZER	
12	52477986	1	THRUST PLATE	
13	52479161	1	CONDUCTOR GEAR	
14	37120000	1	BEARING	
15	52479152	1	DRIVE SHAFT	
16	524A0883	1	THRUST PLATE	

SERIAL
START
920224

COUNTERSHAFT AND CORRESPONDING GEARS

CODE REV
D0801_1_72999

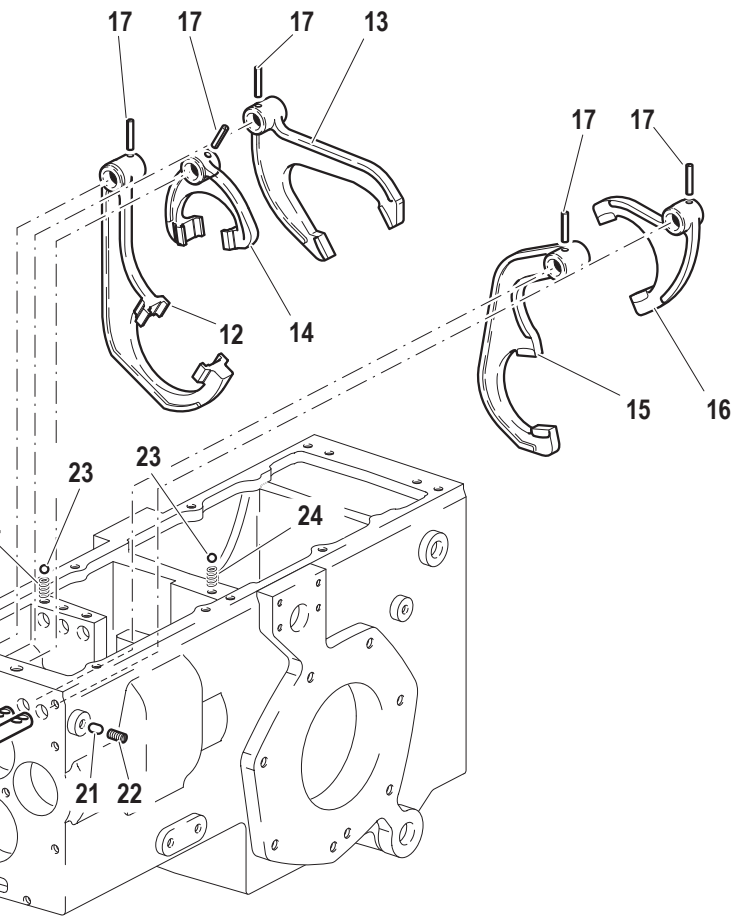
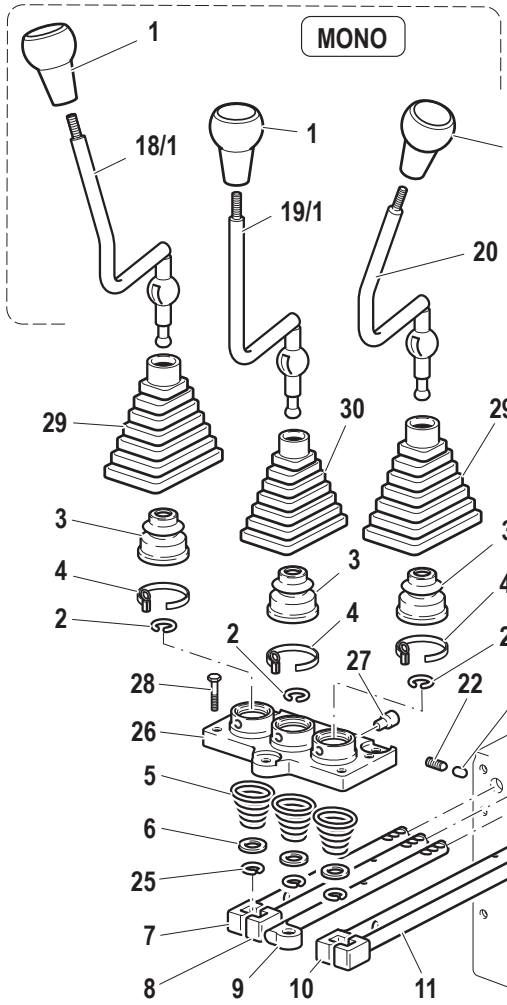
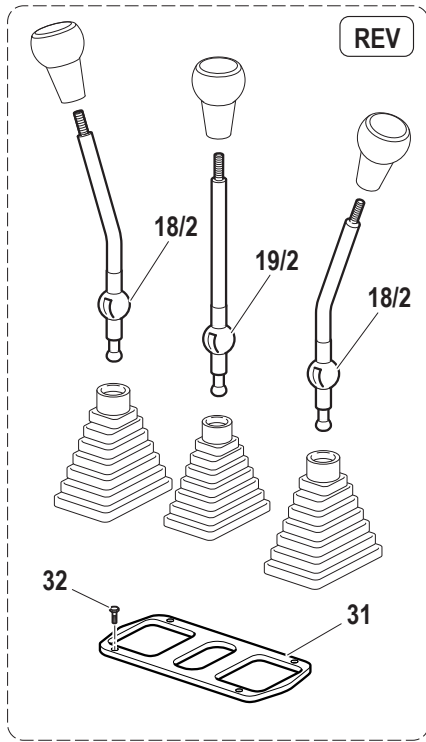

Pos.	Code	Q.ty	Description	Notes
1	58174192	1	HANDLE	
2	58070169	1	LOCKRING	
3	55170053	1	CAP	
4	58170054	1	COLLAR	
5	58070164	1	SPRING	
6	56370172	1	SPACER	
7	56379287	1	PULL ROD	
8	56379290	1	PULL ROD	
9	56379286	1	PULL ROD	
10	56379289	1	PULL ROD	
11	56379288	1	PULL ROD	
12	52275923	1	SELECTOR FORK	
13	52373240	1	SELECTOR FORK	
14	52275924	1	SELECTOR FORK	
15	51272405	1	SELECTOR FORK	
16	51279318	1	GEAR FORK	
17	F0851180000	1	PIN 5X26 DIN 1481 CL:C72	
18/1	59074180	1	COMMAND LEVER	
18/2	52374183	1	COMMAND LEVER	
19/1	59074179	1	COMMAND LEVER	
19/2	52374182	1	COMMAND LEVER	
20	59074181	1	COMMAND LEVER	
21	56571697	1	TOGGLE	
22	F0863105000	1	SCREW M10X10 UNI 5923	
23	F0847434000	1	BALL	
24	58070741	1	SPRING	
25	58070168	1	LOCKRING	
26	51171621	1	COVER	
27	56370018	1	HINGE PIN	
28	F0862694000	1	SCREW M8X170 UNI 5737	
29	55174163	1	BELLOWS	
30	55174162	1	BELLOWS	
31	56074172	1	CLAMPING PLATE	
32	F0861929060	1	SCREW M5X12 UNI 5739	

SERIAL
START
920224

CHANGE GEAR CONTROLS

CODE REV
D0901_2_72753

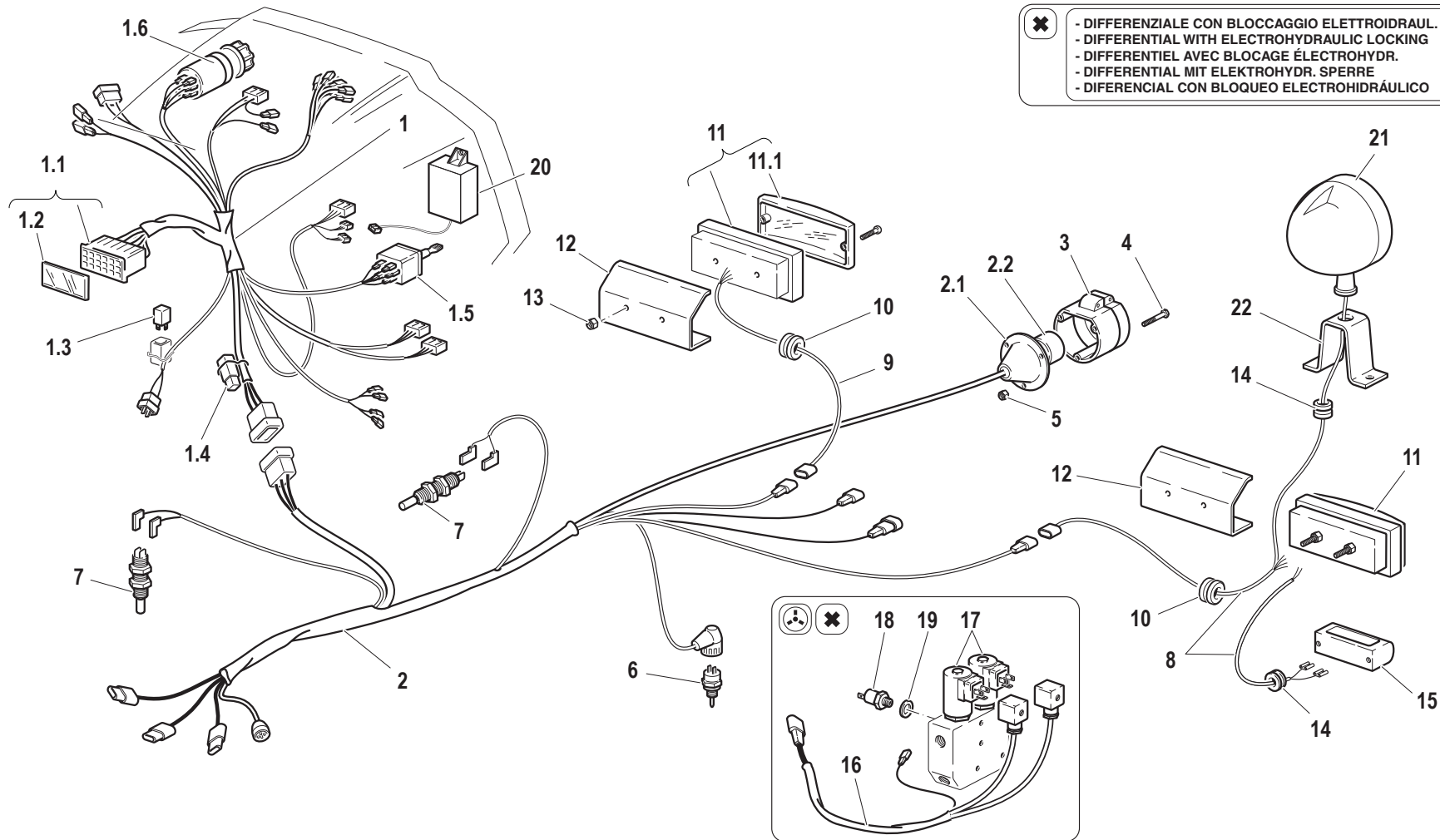

Pos.	Code	Q.ty	Description	Notes
1	58075777	1	CABLE	
1.1	58170453	1	FUSE BOX	
1.2	58172267	1	COVER	
1.3	59900242	1	RELAY	
1.4	F0825139000	1	FLASHER	
1.5	F0825436000	1	SWITCH	
1.6	F0825436003	1	SWITCH	
2	58073593	1	CABLE	
2.1	58170572	1	CAP	
2.2	58170571	1	ATTACHMENT PLUG	
3	F0825438000	1	SOCKET	
4	F0861941000	1	SCREW M5X35 UNI 6107	
5	F0814525000	1	NUT M5	
6	30000638	1	SWITCH	
7	F0825488000	1	SWITCH	
8	58072568	1	CABLE	
9	58071305	1	CABLE	
10	58170947	1	CABLE GLAND	
11	F0825420600	1	LAMP	
11.1	F0825420660	1	GLASS	
12	56171938	1	BRACKET	
13	F0814529080	1	SELFLOCK NUT M5	
14	F0825414000	1	CABLE GLAND 7-15-18,5-2,5	
15	30000506	1	LAMP	
16	58073407	1	CABLE	
17	58172463	1	ELECTRO VALVE	
18	58173399	1	PRESSURE SWITCH	
19	F0843841000	1	COPPER WASHER 12,0x18/1,5	
20	58175700	1	SWITCHING DEVICE	
21	F0825493000	1	HEADLIGHT	
22	F0190035152	1	SUPPORT	

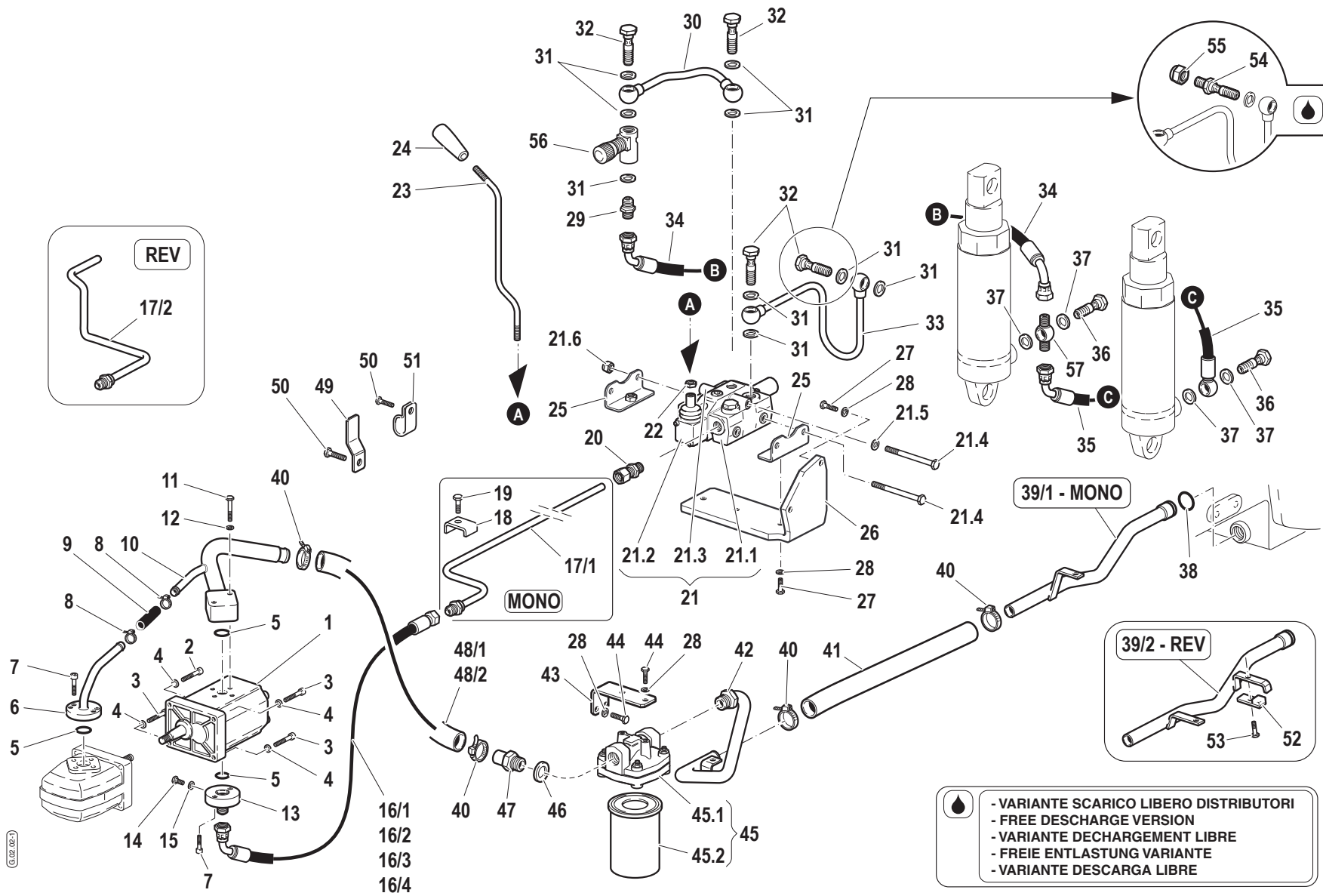

Pos.	Code	Q.ty	Description	Notes
1	58173636	1	LIFT PUMP	
2	31152060	1	SCREW TCEI M6X30 UNI 5931	
3	31152064	1	SCREW TCEI M6X25 UNI 5931	
4	31411064	1	WASHER 6,4x12,5	
5	F0803185000	1	O-RING 3068 (17,12x2,62)	
6	59074413	1	SUCTION PIPE	
7	31152057	1	SCREW TCEI M6X16 UNI 5931	
8	F0817514000	1	CLAMP	
9	F0256612913	1	PIPE	
10	59074412	1	SUCTION PIPE	
11	F0862345000	1	SCREW M6X40 UNI 5737	
12	F0843570000	1	WASHER 6	
13	F0825809000	1	PRESSURE PIPE CONNECTOR	
14	F0862462010	1	SCREW M8X1/12 UNI5740	
15	F0824022000	1	SPECIAL GASKET D.8,4X12/1	
16/1	58072470	1	FLEXIBLE HOSE	
16/2	58072799	1	FLEXIBLE HOSE	
16/3	58072132	1	FLEXIBLE HOSE	
16/4	58072800	1	FLEXIBLE HOSE	
17/1	59072145	1	PIPE	
17/2	59072785	1	PRESSURE PIPE	
18	56172183	1	BRACKET	
19	31112146	1	SCREW TE M8X22 UNI 5739 8G	
20	58172015	1	PIPE FITTING	
21	58172010	1	DISTRIBUTOR	
21.1	58172304	1	HEAD	
21.2	58172011	1	S.A. VALVE	
21.3	58172489	1	COVER	
21.4	58172490	1	ROD	
21.5	31411084	1	WASHER 8,4x17	
21.6	31211080	1	NUT M8	
22	31211100	1	NUT M10	
23	56172769	1	COMMAND LEVER	
24	F0837534010	1	GRIP	

SERIAL
START
900160

HYDRAULIC SYSTEM

CODE REV
G0202_1_65175

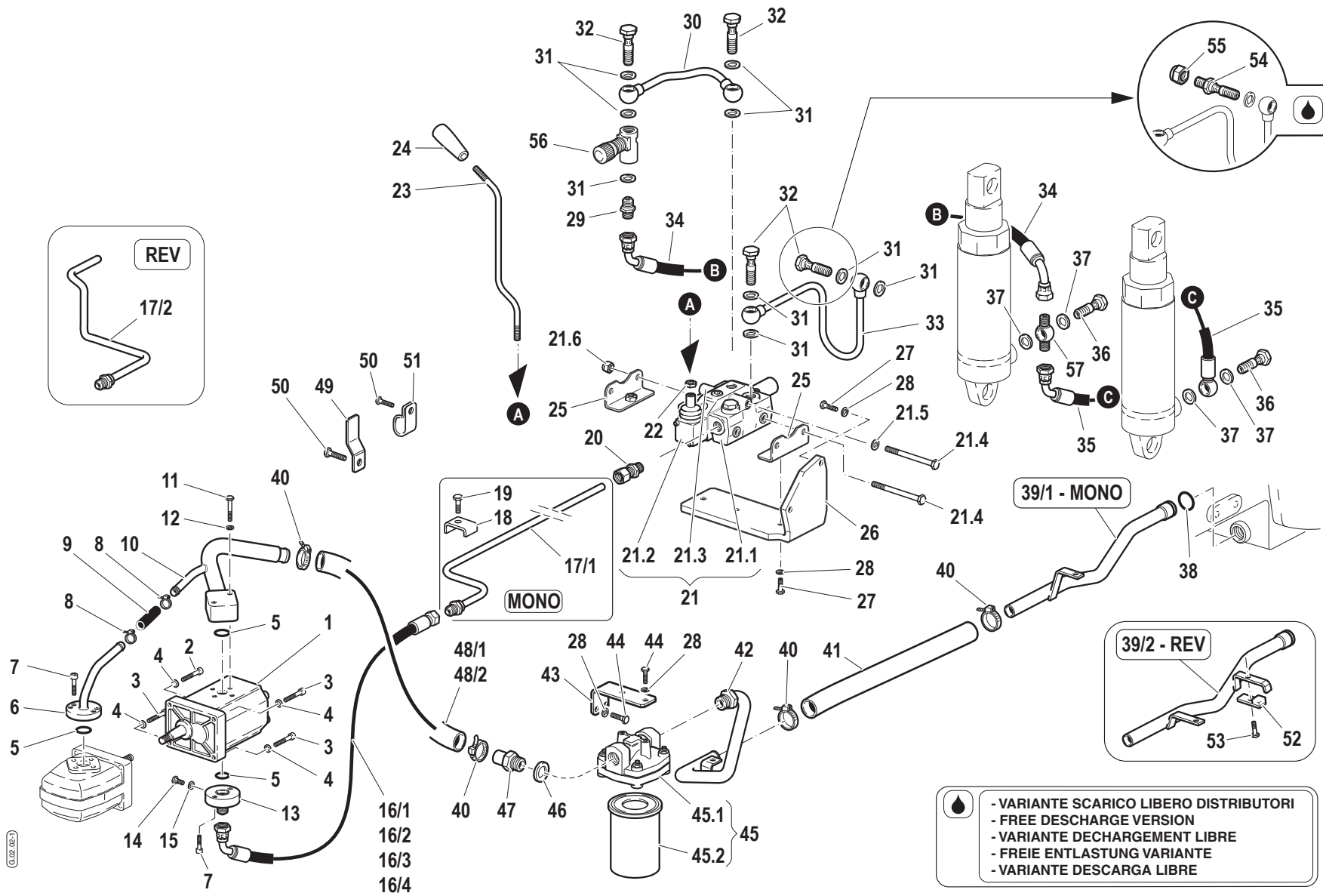

Pos.	Code	Q.ty	Description	Notes
25	59072057	1	FIXING BRACKET	
26	56172561	1	RETAINER	
27	31112146	1	SCREW TE M8X22 UNI 5739 8G	
28	F0843643060	1	WASHER 8	
29	F0835023000	1	NIPPLE	
30	59075386	1	PRESSURE PIPE	
31	F0824110000	1	COPPER WASHER 3/8 GAS	
32	F0843109020	1	PIPE FITTING	
33	59073160	1	EXHAUST	
34	58075372	1	FLEXIBLE HOSE	
35	58072269	1	FLEXIBLE HOSE	
36	F0843107000	1	PIPE FITTING GAS 1/4	
37	F0843907000	1	COPPER WASHER 13,66x19/1,5	
38	38112507	1	O-RING 3100 (25,07X2,62)	
39/1	59072410	1	SUCTION PIPE	
39/2	59072893	1	SUCTION PIPE	
40	F0817530200	1	CLAMP	
41	58170352	1	FLEXIBLE HOSE	
42	59072408	1	SUCTION PIPE	
43	56172411	1	FILTER SUPPORT	
44	31111151	1	SCREW TE M8X16 UNI 5739 8G	
45	F0825718000	1	FILTER	
45.1	F0825718010	1	FILTER HEAD	
45.2	F0825718020	1	FILTER INSERT	
46	F0824185000	1	COPPER WASHER 26X34X1,5	
47	56170350	1	PIPE FITTING	
48/1	58172607	1	FLEXIBLE HOSE	
48/2	58172907	1	FLEXIBLE HOSE	
49	56173247	1	BRACKET	
50	31112270	1	SCREW TE M12X20 UNI 5739	
51	58073300	1	HOSE CLIP	
52	59072826	1	BRACKET	
53	31112089	1	SCREW TE M6X25 UNI 5739 8G	
54	56373163	1	PIPE UNION	

SERIAL
START
900160

HYDRAULIC SYSTEM

CODE REV
G0202_1_65175

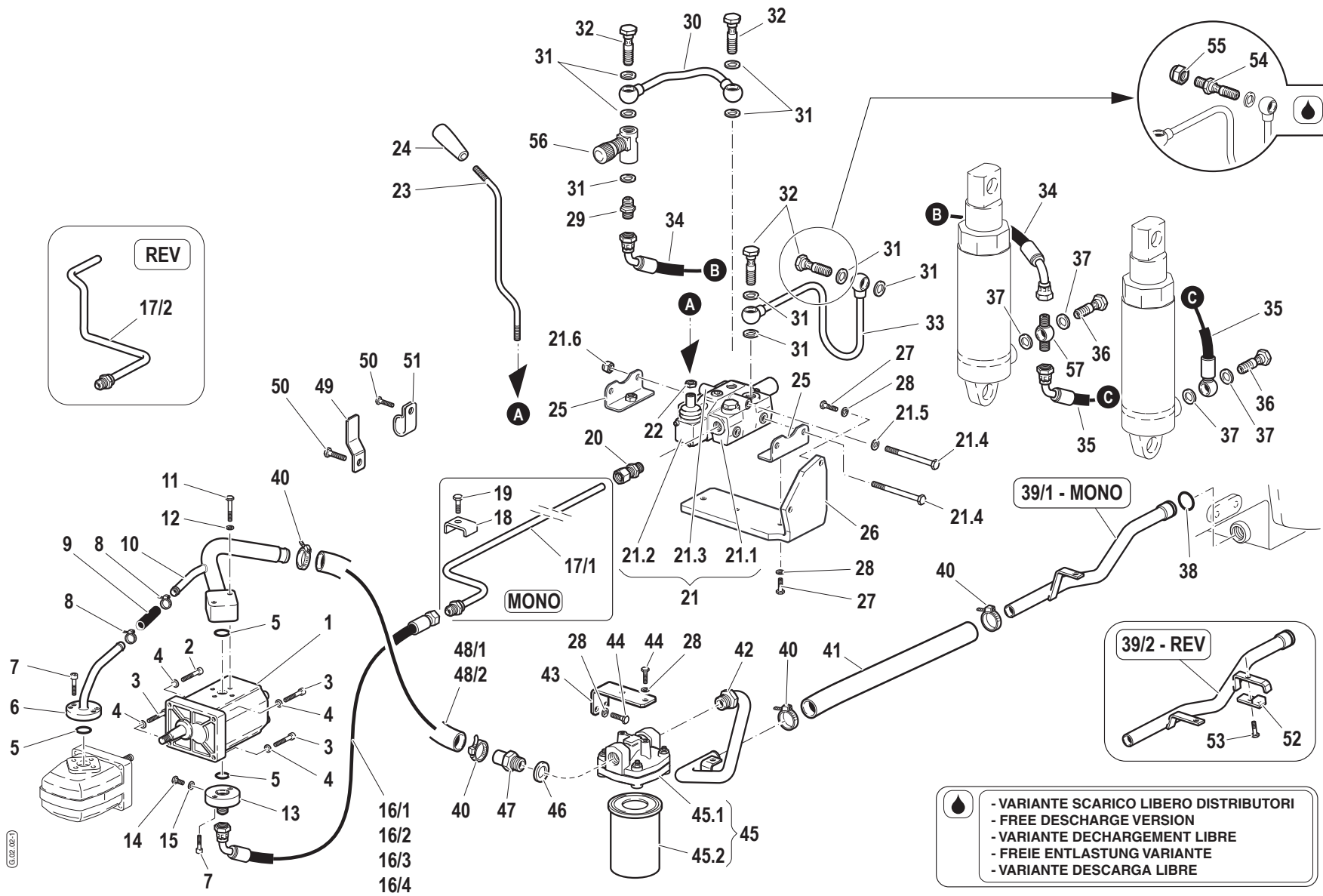

Pos.	Code	Q.ty	Description	Notes
55	F0852589000	1	PLUG	
56	P24117100000	1	VALVE	
57	F0842519050	1	PIPE FITTING	

SERIAL
START
900160

HYDRAULIC SYSTEM

CODE REV
G0202_1_65175

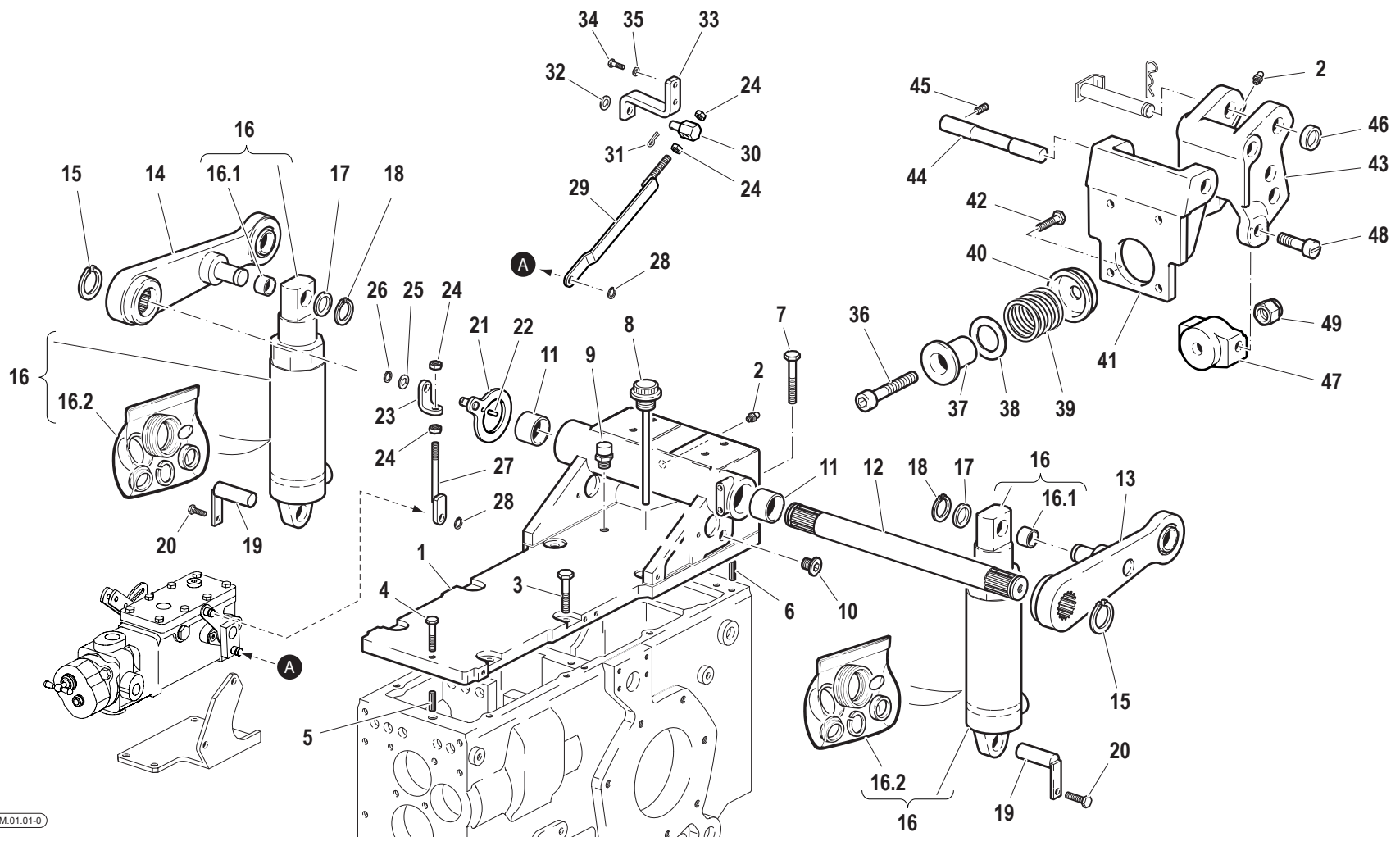

Pos.	Code	Q.ty	Description	Notes
1	51172366	1	SUPPORT	
2	F0826056000	1	LUBRICATOR M10 UNI 7663A	
3	31112219	1	SCREW TE M10X25 UNI 5739	
4	31112154	1	SCREW TE M8X40 UNI 5739 8G	
5	56170017	1	PIN	
6	56370228	1	CYLINDRICAL PLUG	
7	F0863358000	1	SCREW TE M10X40 UNI 5737	
8	58071805	1	PLUG	
9	30040005	1	PLUG	
10	58072045	1	PLUG	
11	58171861	1	BUSHING	
12	56571785	1	SHAFT	
13	59071783	1	LIFTING ARM	
14	59075512	1	RIGHT ARM	
15	F0801264050	1	SEEGER RING E 35X2,5 U/7436	
16	58071534	1	LIFTING CYLINDER	
17	56172905	1	THRUST PLATE	
18	F0801149010	1	SEEGER RING E 20 7436D/471-2	
19	59071786	1	HINGE PIN	
20	31111151	1	SCREW TE M8X16 UNI 5739 8G	
21	59075467	1	SHIM	
22	56570506	1	PIN	
23	56375471	1	BRACKET	
24	F0814569000	1	NUT M8 UNI 5589 CL:8	
25	31411104	1	WASHER 10,5x18	
26	F0801050000	1	SEEGER RING E 10 UNI 7435	
27	59076160	1	ROD	
28	35211070	1	SEEGER RING E 7 UNI 7434	
29	59075476	1	ROD	
30	56075265	1	HINGE PIN	
31	34110030	1	SPLIT PIN	
32	31411104	1	WASHER 10,5x18	
33	56075473	1	BRACKET	
34	31112093	1	SCREW TE M6X20 UNI 5739 8G	

SERIAL

POSITION AND DRAFT CONTROL LIFT

CODE REV

M0101_1_65511

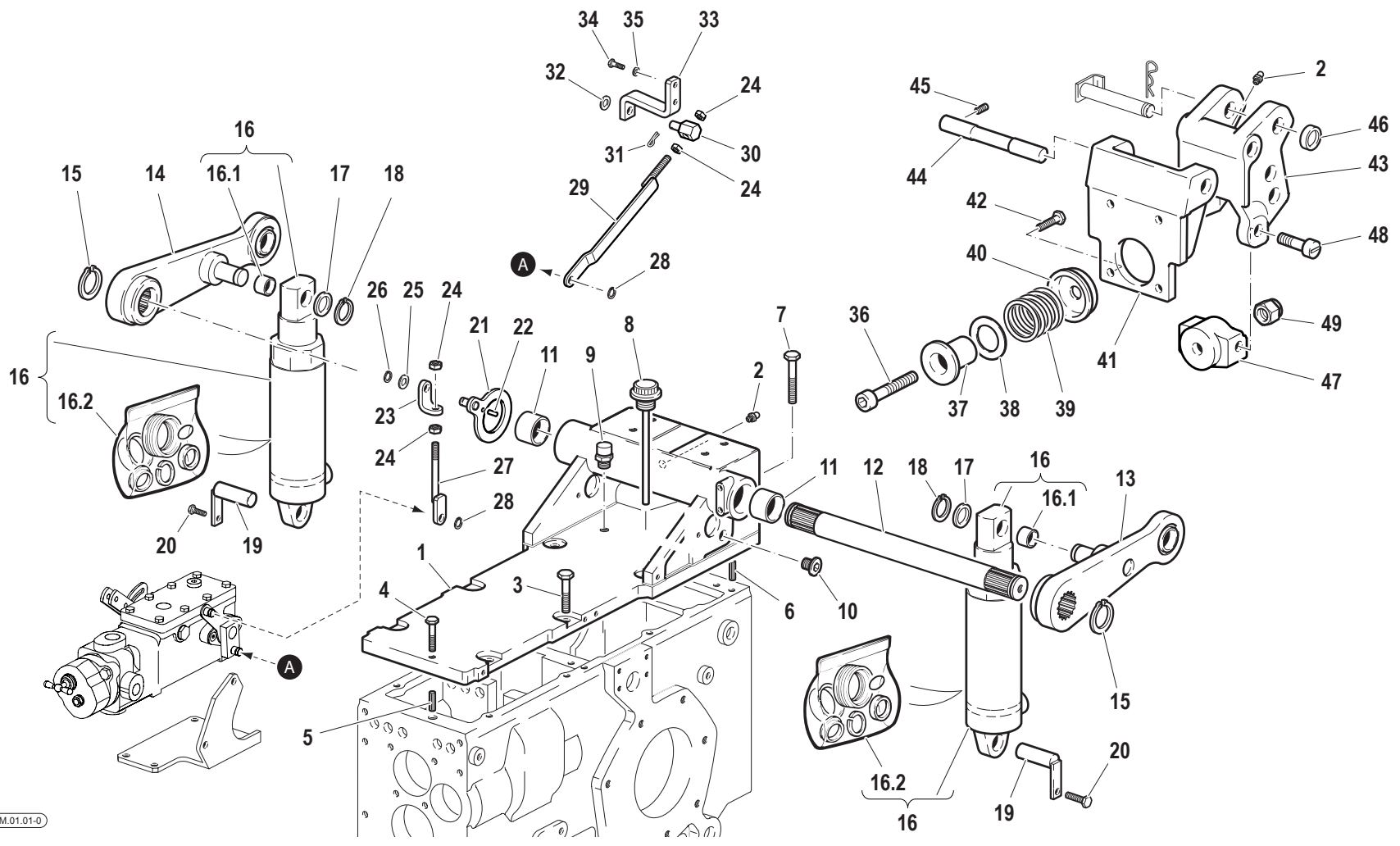

Pos.	Code	Q.ty	Description	Notes
35	F0843570000	1	WASHER 6	
36	F0864322100	1	SCREW M14X1,5/70 UNI5932	
37	56072960	1	SLEEVE	
38	56372952	1	SHIM	
38	56372953	1	SHIM	
38	56372954	1	SHIM	
38	56372955	1	SHIM	
39	58073192	1	SPRING	
40	56073148	1	SLEEVE	
41	51372479	1	BRACKET	
42	31112211	1	SCREW TE M10X30 UNI 5739	
43	51173115	1	THREE-POINT LINKAGE	
44	56472318	1	HINGE PIN	
45	F0862443010	1	SCREW M8X10 UNI 5927	
46	58071757	1	WASHER D.33x19,5/8	
47	51172962	1	SLEEVE	
48	56572959	1	PIN	
49	31241142	1	SELFLOCK NUT M14x1,5	

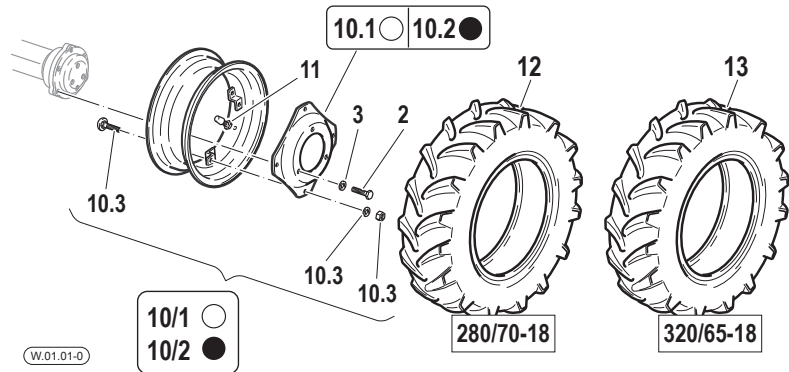
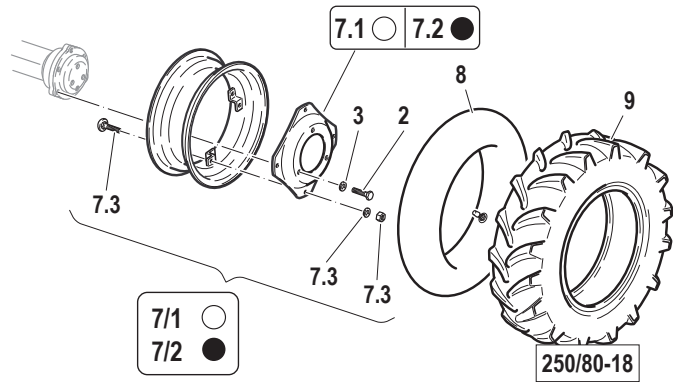
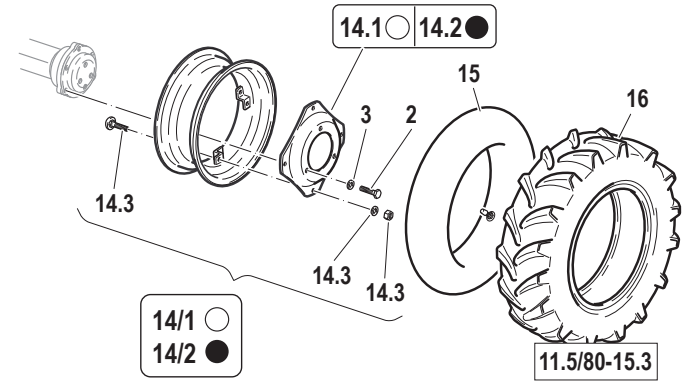
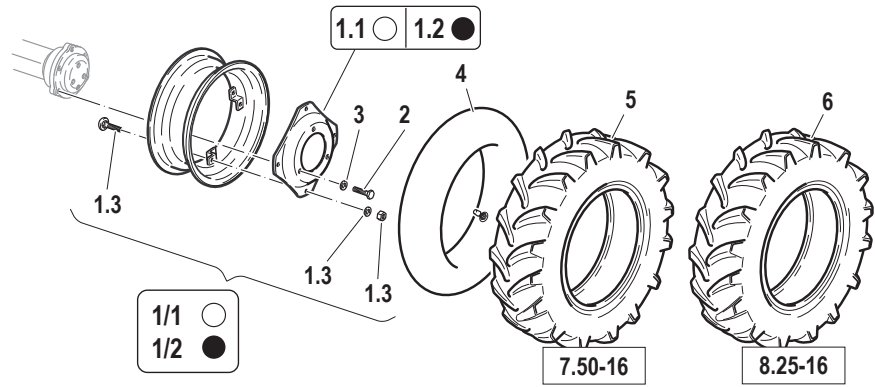

W.01.01-0

ZAVORRA
COUNTERWEIGHT
CONTREPOIDS
BALLAST
CONTRAPESO

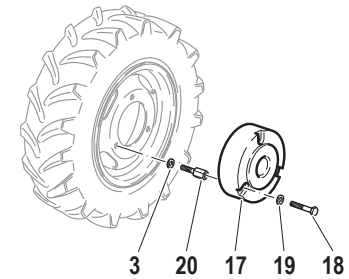

● COLORE GRIGIO
GREY COLOUR
COULEUR GRISE
GRAU FARBE
COLOR GRIS

○ COLORE GIALLO
YELLOW COLOUR
COULEUR JAUNE
GELBE FARBE
COLOR AMARILLO

Pos.	Code	Q.ty	Description	Notes
1/1	58179667	1	RIM	
1.1	581A0367	1	WHEEL DISC	
1.2	581A0368	1	WHEEL DISC	
1/2	58179668	1	RIM	
1.3	59901294	1	SCREW SET	
2	F0864410500	3	SCREW M18X1,5/45 U/5740	
3	F0844150000	3	WASHER D.30x18,5/5	
4	F0848887000	1	INNER TUBE	
5	F0848635000	1	TYRE 7.50-16 8PR	
6	F0848648000	1	TYRE 8.25-16 06 TT	
7.1	581A0158	1	WHEEL DISC	
7/1	59271732	1	RIM	
7/2	59273938	1	RIM	
7.2	581A0159	1	WHEEL DISC	
7.3	59901295	1	SCREW SET	
8	F0848855000	1	INNER TUBE	
9	F0848655000	1	TYRE 250/80-18 8PR	
10/1	59271729	1	RIM	
10.1	581A0152	1	WHEEL DISC	
10.2	581A0153	1	WHEEL DISC	
10/2	59273937	1	RIM	
10.3	59901295	1	SCREW SET	
11	F0150010905	1	VALVE	
12	39118050	1	TYRE 280/70R18	
13	F0848679600	4	TYRE 320/65R18	
14.1	581A0143	1	WHEEL DISC	
14/1	59271888	4	RIM	
14/2	59273939	1	RIM	
14.2	581A0144	1	WHEEL DISC	
14/3	59901293	1	SCREW SET	
15	F0848844000	1	INNER TUBE	
16	F0848672100	1	TYRE 11.5/80-15.3 8PR	
17	51172563	1	BALLAST	
18	F0864314000	1	SCREW M14X65 UNI 5737	

SERIAL

WHEELS AND TYRES

CODE REV

W0101_0_65465

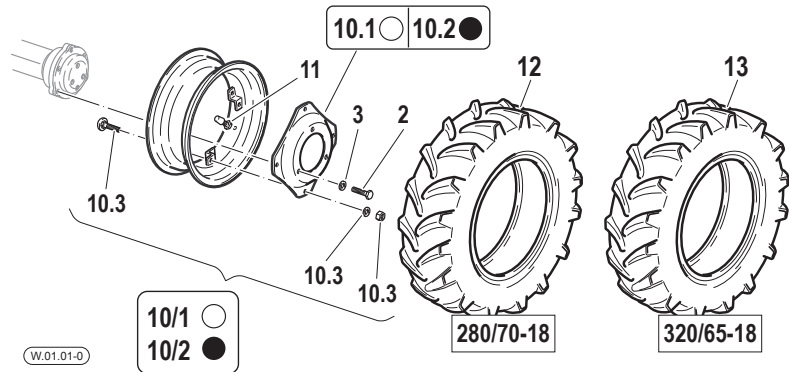
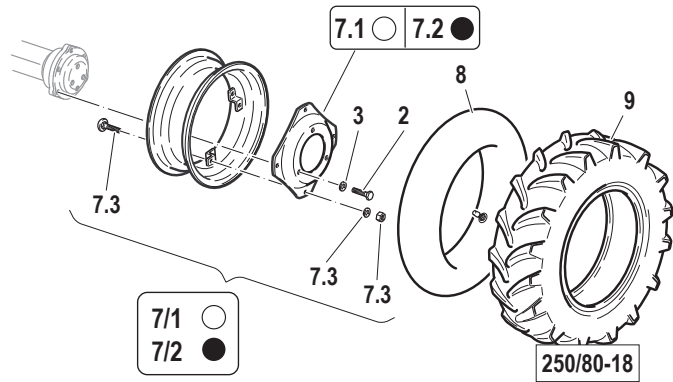
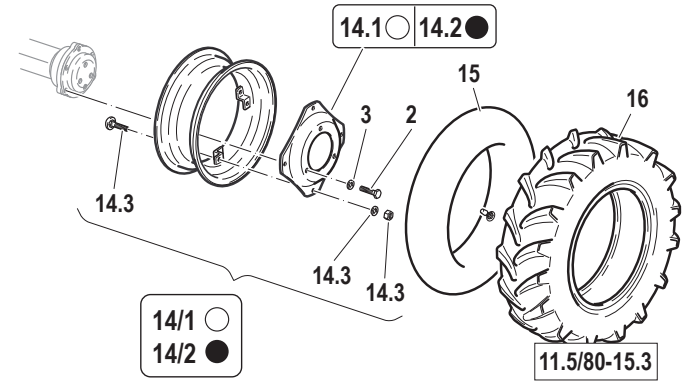
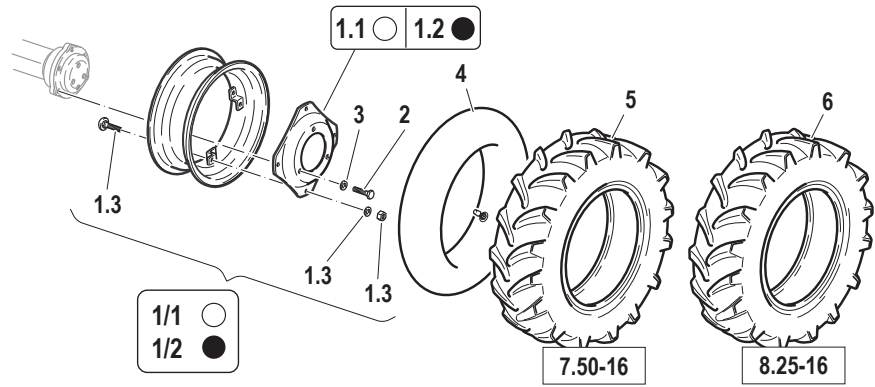

W.01.01-0

ZAVORRA
COUNTERWEIGHT
CONTREPOIDS
BALLAST
CONTRAPESO

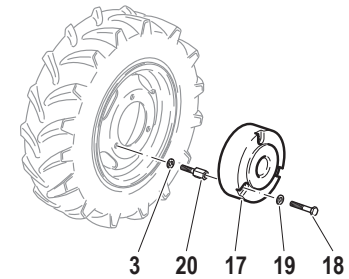

● COLORE GRIGIO
GREY COLOUR
COULEUR GRISE
GRAU FARBE
COLOR GRIS

○ COLORE GIALLA
YELLOW COLOUR
COULEUR JAUNE
GELBE FARBE
COLOR AMARILLO

Pos.	Code	Q.ty	Description	Notes
19	F0843993060	1	WASHER 28x15/4	
20	56370539	1	SPECIAL SCREW	

SPARE PARTS INSTANCE INDEX





SPARE PARTS INSTANCE INDEX

Code	Parts Table	Pos.	Q.ty	Code	Parts Table	Pos.	Q.ty	Code	Parts Table	Pos.	Q.ty
28174882	A0301_1_63276	13	1	31112090	B0501_1_42781	20	1	31112210	A0501_0_2443	14	0
30000007	C0202_2_64535	45	1		D1501_0_3724	10	0	31112211	B0203_0_2593	15	0
30000506	E0301_1_65025	15	1	31112093	D1201_0_3551	9	0		C0102_0_2927	8	0
30000514	B0301_0_2700	11	0		M0101_1_65511	34	1		D0503_0_3281	4	0
30000614	B0501_1_42781	7	1	31112146	G0202_1_65175	19	1		H0101_0_4286	35	0
30000638	E0301_1_65025	6	1		G0202_1_65175	27	1		M0101_1_65511	42	1
30040005	G0101_0_3995	9	0		G0303_0_4180	9	0	31112214	C0102_0_2927	7	0
	H0101_0_4286	9	0		H0202_0_4405	19	0	31112219	A0101_1_63226	3	1
	M0101_1_65511	9	1		H0202_0_4405	31	0		A0102_1_63249	3	1
31111084	H0401_0_4504	15/1	0		H0302_0_4484	9	0		B0203_0_2593	36	0
31111091	A0301_1_63276	14	1	31112147	D0503_0_3281	21	0		C0302_1_72740	11	1
	D0201_0_3112	18	0		D1402_0_3708	3/2	0		D0503_0_3281	3	0
	H0101_0_4286	22	0	31112148	A0101_1_63226	11	1		F0103_0_3917	3	0
31111151	B0203_0_2593	20	0		A0102_1_63249	11	1		G0101_0_3995	3	0
	B0604_0_63758	10	5		A0201_0_2357	11	0		H0101_0_4286	3	0
	D1201_0_3551	19	0	31112150	A0201_0_2357	6	0		M0101_1_65511	3	1
	G0101_0_3995	20	0		B0203_0_2593	28	0	31112224	A0501_0_2443	11	0
	G0202_1_65175	44	1		C0202_2_64535	38	1	31112264	B0301_0_2700	14	0
	H0101_0_4286	20	0		D1302_0_3629	3	0		C0102_0_2927	6	0
	H0202_0_4405	48	0		D1402_0_3708	3/1	0	31112270	A0101_1_63226	5	1
	L0201_0_4601	3	0		D1501_0_3724	8	0		A0102_1_63249	5	1
	L0202_0_4630	2	0		L0201_0_4601	13	0		G0202_1_65175	50	1
	L0203_0_4662	3	0		L0202_0_4630	20	0		H0202_0_4405	54	0
	M0101_1_65511	20	1		L0203_0_4662	13	0	31112272	B0301_0_2700	8	0
31112049	H0101_0_4286	24	0	31112151	B0203_0_2593	11	0		L0201_0_4601	9	0
	H0401_0_4504	10	0		B0701_1_65937	4	1		L0202_0_4630	29	0
	H0401_0_4504	15/2	0		D0503_0_3281	22	0		L0203_0_4662	9	0
31112082	B0203_0_2593	24	0	31112154	G0101_0_3995	4	0	31112328	B0101_0_2468	15	0
	B0301_0_2700	18	1		H0101_0_4286	4	0	31122804	B0203_0_2593	37	0
	D0601_2_72925	21	3		M0101_1_65511	4	1	31132562	A0201_0_2357	2	0
	H0401_0_4504	18	0	31112155	B0701_1_65937	3	1		C0202_2_64535	43	1
31112089	G0202_1_65175	53	1	31112158	H0202_0_4405	23	0	31152057	F0103_0_3917	9	0
	H0202_0_4405	57	0	31112161	D1202_0_3587	15	0		G0202_1_65175	7	1
31112090	B0203_0_2593	46	0	31112208	C0202_2_64535	6	1		H0202_0_4405	7	0

SPARE PARTS INSTANCE INDEX

Code	Parts Table	Pos.	Q.ty	Code	Parts Table	Pos.	Q.ty	Code	Parts Table	Pos.	Q.ty
31152060	F0103_0_3917	14/2	1	31411066	A0301_1_63276	15	1	34211054	D1402_0_3708	5	0
	G0202_1_65175	2	1		B0203_0_2593	25	0	35111027	D0203_1_43188	8	1
	H0202_0_4405	2	0	31411084	B0101_0_2468	11	0		D0203_2_72897	8	1
31152063	F0103_0_3917	14/1	1		B0203_0_2593	8	0	35111042	D1001_0_3471	2	0
31152064	G0202_1_65175	3	1		B0501_1_42781	16	1	35111052	C0202_2_64535	32	1
	H0202_0_4405	3	0		B0701_1_65937	5	1	35111063	D0102_0_3082	11	0
31152085	D1202_0_3587	14	0		G0202_1_65175	21.5	1	35121025	C0202_2_64535	31	1
31211040	H0401_0_4504	16	0		H0202_0_4405	25	0	35121030	D0601_2_72925	11	1
31211060	A0301_1_63276	7	1	31411090	B0203_0_2593	39	0		D1301_0_3604	2	0
	B0203_0_2593	27	0	31411104	D1201_0_3551	4	0		D1401_0_3649	2	0
	B0501_1_42781	23	1		M0101_1_65511	25	1	35121035	D1301_0_3604	3	0
31211080	G0202_1_65175	21.6	1		M0101_1_65511	32	1		D1401_0_3649	3	0
	G0302_0_4169	6	0	31411105	A0101_1_63226	4	1	35121040	D0201_0_3112	3	0
	G0303_0_4180	6	0		A0102_1_63249	4	1	35131026	D0503_0_3281	10	0
	H0302_0_4484	6	0		D0503_0_3281	28	0		D0801_0_3420	1	0
31211100	A0301_1_63276	12	1	31411130	D0401_0_3186	11	0		D0801_1_72999	1	1
	C0102_0_2927	9	0		D0503_0_3281	17	0	35211060	B0101_0_2468	4	0
	G0202_1_65175	22	1	31411150	B0101_0_2468	17	0	35211070	M0101_1_65511	28	1
	G0302_0_4169	10	0		D0503_0_3281	25	0	37111151	D0202_2_72891	2	1
	G0303_0_4180	14	0	31411170	L0201_0_4601	20	0	37111255	D0801_1_72999	2	1
	H0202_0_4405	26	0		L0202_0_4630	8	0	37111299	D0801_0_3420	14	0
	H0302_0_4484	15	0		L0203_0_4662	20	0	37111303	D1301_0_3604	7	0
31212060	H0401_0_4504	19	0	31411190	L0201_0_4601	18	0		D1401_0_3649	14	0
31221080	B0701_1_65937	14	1		L0202_0_4630	16	0	37111353	D1301_0_3604	4	0
31241080	A0501_0_2443	9	0		L0203_0_4662	18	0		D1401_0_3649	4	0
31241100	B0203_0_2593	50	0	31421083	C0202_2_64535	39	1	37111400	D0201_0_3112	5	0
31241140	B0301_0_2700	5	0	31450060	D0601_2_72925	22	3	37111460	D0201_0_3112	19	0
31241142	H0101_0_4286	41	0	31480191	C0302_1_72740	2	1	37112120	C0202_2_64535	40	1
	M0101_1_65511	49	1	31510053	B0501_1_42781	5	1	37112249	C0202_2_64535	33	1
31411064	B0301_0_2700	19	1	34110030	M0101_1_65511	31	1	37120000	D0801_1_72999	14	1
	D1201_0_3551	10	0	34211027	B0701_1_65937	16	1	37221300	D0102_0_3082	10	0
	F0103_0_3917	15	0	34211028	B0701_1_65937	15	1	38104412	C0202_2_64535	27	1
	G0202_1_65175	4	1	34211030	D1201_0_3551	3	0	38110913	D1201_0_3551	20	0
	H0202_0_4405	4	0	34211054	D1302_0_3629	5	0	38111191	D1302_0_3629	14	0



SPARE PARTS INSTANCE INDEX

Code	Parts Table	Pos.	Q.ty	Code	Parts Table	Pos.	Q.ty	Code	Parts Table	Pos.	Q.ty
38112200	D1302_0_3629	9	0	51271615	D1202_0_3587	9	0	52471459	D0701_2_72962	20	1
	D1402_0_3708	9	0	51271647	D1201_0_3551	34	0		D1301_0_3604	10	0
38112507	G0202_1_65175	38	1		D1202_0_3587	8	0	52471475	D1301_0_3604	15	0
	H0202_0_4405	42	0	51272353	D1302_0_3629	17	0	52471476	D1301_0_3604	11	0
38112670	D0102_0_3082	6	0	51272405	D0901_2_72753	15	1	52471477	D1301_0_3604	8	0
38112982	D1501_0_3724	32	0	51276978	C0302_1_72740	8	1	52471478	D1301_0_3604	9	0
38116317	D1401_0_3649	36	0	51276979	C0302_1_72740	9	1	52471502	D0201_0_3112	13	0
38212003	D1001_0_3471	1	0	51279318	D0901_2_72753	16	1	52471509	D0102_0_3082	19	0
38212503	D0201_0_3112	30	0	512A0908	C0102_0_2927	3/1	1		D1001_0_3471	8	0
39118050	W0101_0_65465	12	1	512A0909	C0102_0_2927	2	1	52471511	D1001_0_3471	15/1	0
41S80000	A0101_1_63226	1	1	512A0910	C0102_0_2927	3/2	1	52471512	D1001_0_3471	16/1	0
41S90000	A0102_1_63249	1	1	51372479	H0101_0_4286	34	0	52471513	D0102_0_3082	15	0
50972173	D0503_0_3281	30	0		M0101_1_65511	41	1		D1001_0_3471	6	0
50974166	D0601_2_72925	17	1	51374866	D0102_0_3082	20	0	52471516	D0102_0_3082	16	0
51171603	C0302_1_72740	6	1		D1001_0_3471	11	0		D1001_0_3471	7	0
51171604	C0302_1_72740	7	1	52071702	D0201_0_3112	17	0	52471531	D1102_0_3525	12/1	0
51171614	C0102_0_2927	1	0	52171744	D0201_0_3112	29	0	52471532	D0102_0_3082	24/1	0
51171621	D0901_2_72753	26	1	52172158	C0202_2_64535	21	1		D1001_0_3471	19/1	0
51171641	G0101_0_3995	1/1	1	52172159	C0202_2_64535	21	1	52471533	D1102_0_3525	4/1	0
51171648	D1301_0_3604	17	0	52172160	C0202_2_64535	21	1	52472272	D1401_0_3649	6	0
51171842	D0201_0_3112	24	0	52172161	C0202_2_64535	21	1	52472273	D1401_0_3649	11	0
51172366	H0101_0_4286	1	0	52172162	C0202_2_64535	21	1	52472322	D1401_0_3649	28	0
	M0101_1_65511	1	1	52275923	D0901_2_72753	12	1	52472324	D1401_0_3649	42	0
51172508	D1102_0_3525	3	0	52275924	D0901_2_72753	14	1	52472325	D1401_0_3649	9	0
51172563	W0101_0_65465	17	1	52371679	D1302_0_3629	10	0	52472342	D1401_0_3649	27	0
51172962	H0101_0_4286	40	0		D1402_0_3708	10	0	52472344	D0203_1_43188	7	1
	M0101_1_65511	47	1	52371733	D0201_0_3112	26	0		D0203_2_72897	7	1
51173115	H0101_0_4286	38	0	52372292	D1401_0_3649	22	0	52472430	D1302_0_3629	11	0
	M0101_1_65511	43	1	52372343	D1202_0_3587	1	0		D1402_0_3708	11	0
51174228	B0101_0_2468	12	0	52373177	D0503_0_3281	18	0	52472494	D1301_0_3604	5	0
51175011	L0302_0_4700	1.2	0	52373240	D0901_2_72753	13	1	52473001	D1401_0_3649	39	0
51178584	G0101_0_3995	1/2	1	52374182	D0901_2_72753	19/2	1	52473713	D0801_0_3420	7	0
511A0898	C0302_1_72740	1	1	52374183	D0901_2_72753	18/2	1	52473719	D0801_0_3420	9	0
51271615	D1201_0_3551	22	0	523A0166	C0202_2_64535	19	1	52473720	D0801_0_3420	13	0



SPARE PARTS INSTANCE INDEX

Code	Parts Table	Pos.	Q.ty	Code	Parts Table	Pos.	Q.ty	Code	Parts Table	Pos.	Q.ty
52473721	D0701_2_72962	19	1	52479162	D0701_2_72962	15	1	56072960	H0101_0_4286	30	0
52473722	D0801_0_3420	15	0	52479163	D0701_2_72962	7	1		M0101_1_65511	37	1
52473789	D0701_2_72962	6	1	52479164	D0701_2_72962	12	1	56073148	H0101_0_4286	33	0
52473791	D0801_0_3420	3	0	52479165	D0801_1_72999	9	1		M0101_1_65511	40	1
	D0801_1_72999	3	1	524A0883	D0801_1_72999	16	1	56073153	L0301_0_4690	5	0
52473793	D0801_0_3420	12	0	524A0886	D0202_2_72891	1	1	56073155	L0301_0_4690	1	0
52473796	D0701_2_72962	17	1	524A0887	D0203_2_72897	1	1	56074172	D0901_2_72753	31	1
52473812	D0701_2_72962	6	1	52571740	D0203_1_43188	5/1	1	56074233	L0201_0_4601	6	0
52473813	D0701_2_72962	6	1		D0203_2_72897	5/1	1		L0203_0_4662	6	0
52473815	D0801_0_3420	3	0	52572460	D0202_2_72891	3/1	1	56074234	L0201_0_4601	7	0
	D0801_1_72999	3	1	52572486	D0202_2_72891	3/2	1		L0203_0_4662	7	0
52473920	D1102_0_3525	4/2	0	52572605	D1001_0_3471	18	0	56075018	L0302_0_4700	1.1	0
52473921	D1102_0_3525	12/2	0	52572606	D1001_0_3471	17	0	56075265	M0101_1_65511	30	1
52473922	D0102_0_3082	24/2	0	53272293	D1401_0_3649	17	0	56075473	M0101_1_65511	33	1
	D1001_0_3471	19/2	0	53273000	D1401_0_3649	38	0	560A0221	D1301_0_3604	24	1
52473923	D1001_0_3471	15/2	0	55072935	B0203_0_2593	23	0		D1401_0_3649	53	1
52473924	D1001_0_3471	16/2	0	55170047	D0401_0_3186	9	0	56170017	G0101_0_3995	5	0
52474190	D1301_0_3604	1	0	55170053	D0901_2_72753	3	1		H0101_0_4286	5	0
	D1401_0_3649	1	0	55171747	A0301_1_63276	3	1		M0101_1_65511	5	1
52474239	D0801_0_3420	3	0	55171748	A0301_1_63276	9	1	56170043	D0401_0_3186	10	0
	D0801_1_72999	3	1	55171751	A0401_0_2427	4	0	56170226	C0202_2_64535	18	1
52475921	D0601_2_72925	7.1	2	55172608	C0202_2_64535	41	1	56170274	A0501_0_2443	5	0
52476391	D0203_1_43188	1	1	55174162	D0901_2_72753	30	1	56170275	A0501_0_2443	6	0
52477986	D0801_1_72999	12	1	55174163	D0901_2_72753	29	1	56170350	G0202_1_65175	47	1
52477987	D0801_1_72999	3	1	55175174	B0203_0_2593	19	1		H0202_0_4405	51	0
52479152	D0801_1_72999	15	1	55271644	B0501_1_42781	4/2	1	56170413	D1501_0_3724	15	0
52479153	D0801_1_72999	7	1	55271852	B0501_1_42781	4/1	1	56171233	E0101_0_3772	10	0
52479154	D0601_2_72925	6	1	55274164	A0501_0_2443	1	0	56171499	D0201_0_3112	15	0
52479155	D0601_2_72925	9	1	55274441	B0501_1_42781	3	1	56171568	D1102_0_3525	7/1	0
52479156	D0601_2_72925	13	1	55274442	H0401_0_4504	14	0	56171671	D0102_0_3082	7	0
52479157	D0701_2_72962	25	1	553A0763	B0701_1_65937	9	1	56171672	D0102_0_3082	9	0
52479158	D0601_2_72925	16	1	56071681	B0101_0_2468	3	0	56171704	B0301_0_2700	2	0
52479160	D0701_2_72962	23	1	56071684	B0101_0_2468	2	0	56171760	A0401_0_2427	2	0
52479161	D0801_1_72999	13	1	56071768	A0201_0_2357	10	0	56171775	A0501_0_2443	13	0

SPARE PARTS INSTANCE INDEX

Code	Parts Table	Pos.	Q.ty	Code	Parts Table	Pos.	Q.ty	Code	Parts Table	Pos.	Q.ty
56171787	D0503_0_3281	14	0	56172751	D1501_0_3724	7/2	0	56174873	B0101_0_2468	14	0
56171788	L0201_0_4601	25	0	56172759	D1501_0_3724	7/1	0	56178591	B0604_0_63758	14	1
	L0202_0_4630	27	0	56172769	G0202_1_65175	23	1	561A0764	B0701_1_65937	8	1
	L0203_0_4662	25	0		G0302_0_4169	7	0	56271457	D0701_2_72962	22	1
56171789	L0201_0_4601	24	0		G0303_0_4180	16	0	56276359	C0202_2_64535	26.2	1
	L0202_0_4630	28	0		H0202_0_4405	27	0	56276360	C0202_2_64535	26.1	1
	L0203_0_4662	24	0		H0302_0_4484	16	0	56349629	D0503_0_3281	9	1
56171847	D0201_0_3112	6	0	56172770	G0302_0_4169	8	0	56370018	D0901_2_72753	27	1
56171877	A0201_0_2357	3	0		G0303_0_4180	15	0	56370081	D1102_0_3525	14	0
56171883	A0201_0_2357	4	0		H0302_0_4484	17	0	56370172	D0901_2_72753	6	1
56171934	D0201_0_3112	8	0	56172905	G0101_0_3995	17	0	56370178	C0202_2_64535	17	1
56171936	D0503_0_3281	31	1		H0101_0_4286	17	0	56370187	D1202_0_3587	4	0
56171938	E0101_0_3772	8	0		M0101_1_65511	17	1	56370228	C0202_2_64535	1.4	1
	E0301_1_65025	12	1	56172926	H0101_0_4286	25	0		G0101_0_3995	6	0
56171954	B0203_0_2593	18	0	56173016	D1402_0_3708	12	0		H0101_0_4286	6	0
56171996	B0203_0_2593	38	0	56173022	H0101_0_4286	21	0		M0101_1_65511	6	1
56172009	D1201_0_3551	7	0	56173056	H0401_0_4504	17	0	56370539	W0101_0_65465	20	1
56172019	D0503_0_3281	13	0	56173210	A0201_0_2357	14	0	56370583	D1202_0_3587	11	0
56172079	D1301_0_3604	23	0	56173247	G0202_1_65175	49	1	56371210	L0201_0_4601	27/1	1
56172080	D1301_0_3604	22	0		H0202_0_4405	53	0		L0202_0_4630	22/1	1
	D1401_0_3649	52	0	56173919	D1102_0_3525	7/2	0		L0203_0_4662	27/1	1
56172129	B0203_0_2593	48	0	56174135	B0203_0_2593	5	0	56371440	D0601_2_72925	3	2
56172163	C0202_2_64535	42	1	56174136	B0203_0_2593	41	0	56371551	D0201_0_3112	14	0
56172172	B0602_0_63791	7/2	1	56174137	B0203_0_2593	40	0	56371575	D1102_0_3525	5	0
56172183	G0202_1_65175	18	1	56174275	A0101_1_63226	9	1	56371576	D1102_0_3525	5	0
	H0202_0_4405	18	0		A0102_1_63249	9	1	56371577	D1102_0_3525	5	0
56172411	G0202_1_65175	43	1	56174307	A0501_0_2443	18	0	56371578	D1102_0_3525	5	0
	H0202_0_4405	47	0	56174337	B0203_0_2593	22	0	56371579	D1102_0_3525	5	0
56172483	H0101_0_4286	28	0	56174365	B0203_0_2593	44	0	56371582	C0102_0_2927	14	0
56172561	G0202_1_65175	26	1	56174366	B0203_0_2593	43	0		D1001_0_3471	14	0
	H0202_0_4405	30	0	56174424	B0101_0_2468	1.1	0	56371583	C0102_0_2927	14	0
56172749	D1501_0_3724	1	0	56174425	B0101_0_2468	1.3	0		D1001_0_3471	14	0
56172750	G0303_0_4180	8	0	56174426	B0101_0_2468	1.2	0	56371584	C0102_0_2927	14	0
	H0302_0_4484	8	0	56174427	B0101_0_2468	1.4	0		D1001_0_3471	14	0

SPARE PARTS INSTANCE INDEX

Code	Parts Table	Pos.	Q.ty	Code	Parts Table	Pos.	Q.ty	Code	Parts Table	Pos.	Q.ty
56371585	C0102_0_2927	14	0	56372086	L0202_0_4630	11	0	56471461	D0701_2_72962	24	1
	D1001_0_3471	14	0		L0203_0_4662	19	0	56471508	D0102_0_3082	17	0
56371586	C0102_0_2927	14	0	56372282	D1401_0_3649	25	0		D1001_0_3471	10	0
	D1001_0_3471	14	0	56372346	L0202_0_4630	6	0	56471645	C0202_2_64535	29	1
56371605	D0401_0_3186	4	0	56372474	D1501_0_3724	34	0	56471654	D0601_2_72925	10	1
56371606	D0401_0_3186	3	0	56372952	H0101_0_4286	31	0	56471655	D0701_2_72962	4	1
56371613	D1202_0_3587	10	0		M0101_1_65511	38	1	56471665	D0102_0_3082	5	0
56371616	D1201_0_3551	21	0	56372953	H0101_0_4286	31	0	56471709	D0401_0_3186	7	0
56371646	D1201_0_3551	33	0		M0101_1_65511	38	1	56471728	D0201_0_3112	21	0
	D1202_0_3587	5	0	56372954	H0101_0_4286	31	0	56471813	D0301_0_3162	5	0
56371652	D0701_2_72962	1	1		M0101_1_65511	38	1	56472318	H0101_0_4286	36	0
56371661	D0701_2_72962	26	1	56372955	H0101_0_4286	31	0		M0101_1_65511	44	1
56371662	D0701_2_72962	26	1		M0101_1_65511	38	1	56472363	D0203_1_43188	4	1
56371663	D0701_2_72962	26	1	56373163	G0202_1_65175	54	1		D0203_2_72897	4	1
56371664	D0701_2_72962	26	1		H0202_0_4405	58	0	56472368	D1401_0_3649	32	0
56371666	D0102_0_3082	4	0	56373349	D1102_0_3525	5	0	56472374	D1401_0_3649	34/1	0
56371667	D0102_0_3082	12	0	56373350	D1102_0_3525	5	0	56472375	D1401_0_3649	34/2	0
56371668	D0102_0_3082	12	0	56373440	D0701_2_72962	26	1	56472376	D1401_0_3649	34/3	0
56371669	D0102_0_3082	12	0	56373502	L0301_0_4690	6	0	56472377	D1401_0_3649	47.1	1
56371670	D0102_0_3082	12	0	56373542	C0202_2_64535	16	1	56472383	D1401_0_3649	35	0
56371675	D1302_0_3629	18	0	56374460	B0701_1_65937	6	1	56472390	D1401_0_3649	43	0
56371678	D1302_0_3629	19	0	56375436	B0701_1_65937	2	1	56570506	M0101_1_65511	22	1
56371708	D0401_0_3186	6	0	56375471	M0101_1_65511	23	1	56571697	D0901_2_72753	21	1
56371714	D0301_0_3162	8	1	56377980	L0302_0_4700	1.4	1	56571785	G0101_0_3995	12	0
56371715	D0301_0_3162	9	1	56379286	D0901_2_72753	9	1		H0101_0_4286	12	0
56371777	D1201_0_3551	16	0	56379287	D0901_2_72753	7	1		M0101_1_65511	12	1
56371810	D1201_0_3551	28	0	56379288	D0901_2_72753	11	1	56571824	L0201_0_4601	1	0
56371994	D0102_0_3082	18	0	56379289	D0901_2_72753	10	1		L0203_0_4662	1	0
	D1001_0_3471	9	0	56379290	D0901_2_72753	8	1	56572156	C0202_2_64535	30	1
56372067	L0201_0_4601	26	0	56470030	D1501_0_3724	29.1	0	56572337	L0202_0_4630	1	0
	L0202_0_4630	26	0	56470110	D1301_0_3604	13	0	56572475	D1501_0_3724	29.2	1
	L0203_0_4662	26	0	56470365	D0503_0_3281	27	0	56572623	D0102_0_3082	22	0
	L0301_0_4690	4	0	56470797	D0503_0_3281	15	0	56572624	D0102_0_3082	23	0
56372086	L0201_0_4601	19	0	56471441	D0601_2_72925	4	1	56572959	H0101_0_4286	39	0



SPARE PARTS INSTANCE INDEX

Code	Parts Table	Pos.	Q.ty	Code	Parts Table	Pos.	Q.ty	Code	Parts Table	Pos.	Q.ty
56572959	M0101_1_65511	48	1	58070741	D1302_0_3629	7	0	58072132	H0202_0_4405	16/3	0
57174884	A0501_0_2443	1.3	0		D1402_0_3708	7	0	58072133	F0103_0_3917	20	0
57370321	B0701_1_65937	10	1	58070743	C0202_2_64535	1.3	1	58072134	F0103_0_3917	21	0
57371825	A0401_0_2427	8	0	58071305	E0301_1_65025	9	1	58072137	F0103_0_3917	16	0
57371900	A0501_0_2443	2	0	58071307	E0101_0_3772	5	0	58072138	G0303_0_4180	20	0
57372345	F0103_0_3917	25	0	58071308	E0101_0_3772	4	0		I0102_0_4552	11	0
57374133	B0203_0_2593	3	0	58071313	E0201_0_3784	9	0	58072269	G0202_1_65175	35	1
57374134	B0203_0_2593	4	0	58071375	A0201_0_2357	8	0	58072382	D1401_0_3649	33	0
57374195	B0501_1_42781	18	1	58071534	G0101_0_3995	16	0	58072389	D1401_0_3649	23	0
57374338	B0203_0_2593	32	0		H0101_0_4286	16	0	58072398	D1401_0_3649	29	0
57374339	B0203_0_2593	33	0		M0101_1_65511	16	1	58072399	D1401_0_3649	26	0
573A0715	G0101_0_3995	21	1	58071552	D0201_0_3112	16	0	58072465	L0201_0_4601	28	0
	H0101_0_4286	44	1	58071734	D0201_0_3112	22	0		L0202_0_4630	31	0
58024193	D0701_2_72962	3	1	58071757	H0101_0_4286	43	0	58072470	G0202_1_65175	16/1	1
58024194	D0701_2_72962	3	1		M0101_1_65511	46	1		H0202_0_4405	16/1	0
58024195	D0701_2_72962	3	1	58071790	C0102_0_2927	12	0	58072484	H0101_0_4286	29	0
58024196	D0701_2_72962	3	1		D0201_0_3112	27	0	58072505	D0701_2_72962	11	1
58045806	B0501_1_42781	7.1	1	58071793	C0202_2_64535	1.2	1		D0801_0_3420	10	0
58048002	A0201_0_2357	13	0	58071794	C0202_2_64535	1.1	1		D0801_1_72999	10	1
58070097	B0301_0_2700	3	0	58071805	G0101_0_3995	8	0	58072509	B0401_0_2718	21	1
58070164	D0901_2_72753	5	1		H0101_0_4286	8	0	58072510	B0401_0_2718	20	1
58070168	D0901_2_72753	25	1		M0101_1_65511	8	1	58072511	B0401_0_2718	23	1
58070169	D0901_2_72753	2	1	58071806	D1501_0_3724	35	0	58072517	B0401_0_2718	22	1
58070198	D1201_0_3551	27	0	58071998	L0201_0_4601	5	0	58072520	B0401_0_2718	19	0
	D1202_0_3587	7	0		L0203_0_4662	5	0	58072568	E0301_1_65025	8	1
58070205	D1201_0_3551	24	0	58072045	C0202_2_64535	12	1	58072573	B0401_0_2718	12	0
	D1202_0_3587	13	0		G0101_0_3995	10	0	58072575	B0401_0_2718	13	0
58070366	D0401_0_3186	12	0		H0101_0_4286	10	0	58072626	L0201_0_4601	15	0
58070373	D0503_0_3281	11	0		M0101_1_65511	10	1		L0202_0_4630	14	0
58070390	B0701_1_65937	7	1	58072046	C0202_2_64535	11	1		L0203_0_4662	15	0
58070416	D1501_0_3724	17/1	0	58072074	A0201_0_2357	7/2	0	58072642	L0201_0_4601	16	0
58070489	A0201_0_2357	7/1	0	58072081	E0201_0_3784	10	0		L0202_0_4630	15	0
58070690	A0501_0_2443	17	0	58072130	F0103_0_3917	7	0		L0203_0_4662	16	0
58070741	D0901_2_72753	24	1	58072132	G0202_1_65175	16/3	1	58072737	B0401_0_2718	10	0



SPARE PARTS INSTANCE INDEX

Code	Parts Table	Pos.	Q.ty	Code	Parts Table	Pos.	Q.ty	Code	Parts Table	Pos.	Q.ty
58072792	D1501_0_3724	17/2	0	58074109	D0701_2_72962	3	1	58170968	B0301_0_2700	12	0
58072793	F0103_0_3917	26	0	58074220	B0401_0_2718	8	0	58171029	A0401_0_2427	1.6	0
58072795	I0102_0_4552	12	0	58074222	B0401_0_2718	9	0	58171212	A0501_0_2443	19	0
58072796	I0102_0_4552	13	0	58074223	B0401_0_2718	7	0	58171558	D0201_0_3112	11	0
58072799	G0202_1_65175	16/2	1	58074344	D1501_0_3724	17/3	0	58171559	D0201_0_3112	12	0
	H0202_0_4405	16/4	0	58074377	E0101_0_3772	1	0	58171567	D1102_0_3525	10	0
58072800	G0202_1_65175	16/4	1	58074380	B0401_0_2718	1/1	0	58171596	D0301_0_3162	2	0
	H0202_0_4405	16/2	0	58074381	B0401_0_2718	1/2	0		D0503_0_3281	2	0
58073018	B0401_0_2718	16	0	58075372	G0202_1_65175	34	1	58171653	D1102_0_3525	11	0
	H0401_0_4504	12	0	58075777	B0501_1_42781	6	1	58171673	D0102_0_3082	1	0
58073019	B0401_0_2718	17	0		E0301_1_65025	1	1	58171706	D0401_0_3186	1	0
	H0401_0_4504	13	0	58076077	B0401_0_2718	24	1	58171707	D0401_0_3186	2	0
58073020	H0202_0_4405	38	0	58170013	C0202_2_64535	28	1	58171749	A0401_0_2427	1	0
58073156	B0401_0_2718	15	0	58170054	D0901_2_72753	4	1	58171761	A0101_1_63226	10	1
58073183	D1501_0_3724	27	0	58170077	C0202_2_64535	24	1		A0102_1_63249	10	1
58073192	H0101_0_4286	32	0	58170195	D1202_0_3587	3	0	58171861	G0101_0_3995	11	0
	M0101_1_65511	39	1	58170238	A0501_0_2443	3	0		H0101_0_4286	11	0
58073237	A0501_0_2443	16	0	58170344	B0501_1_42781	24	1		M0101_1_65511	11	1
58073300	G0202_1_65175	51	1	58170345	B0501_1_42781	25	1	58171868	B0101_0_2468	8	0
	H0202_0_4405	55	0	58170352	G0202_1_65175	41	1	58171901	A0501_0_2443	20	0
58073407	D1501_0_3724	38	0		H0202_0_4405	45	0	58172010	G0202_1_65175	21	1
	E0301_1_65025	16	1	58170376	B0501_1_42781	14	1	58172011	G0202_1_65175	21.2	1
58073544	H0202_0_4405	39	0		H0401_0_4504	6	0		G0302_0_4169	2	0
58073548	B0401_0_2718	3	0	58170436	B0101_0_2468	9	0		G0303_0_4180	1.2	0
58073549	B0401_0_2718	2	0	58170449	L0201_0_4601	11	0		I0102_0_4552	1	0
58073552	B0401_0_2718	4/2	0		L0202_0_4630	18	0	58172012	G0303_0_4180	1.3	0
58073553	B0401_0_2718	4/1	0		L0203_0_4662	11	0		I0102_0_4552	3	0
58073554	B0401_0_2718	5	0	58170453	B0501_1_42781	6.1	1	58172013	I0102_0_4552	4	0
58073593	E0301_1_65025	2	1		E0301_1_65025	1.1	1	58172014	I0102_0_4552	5	0
58073596	E0201_0_3784	1	0	58170571	E0301_1_65025	2.2	1	58172015	G0202_1_65175	20	1
58073646	B0401_0_2718	6/1	0	58170572	E0301_1_65025	2.1	1		H0202_0_4405	20	0
58073647	B0401_0_2718	6/2	0	58170580	A0101_1_63226	8	1	58172016	G0302_0_4169	4	0
58073788	D0601_2_72925	18	1		A0102_1_63249	8	1		G0303_0_4180	5/2	0
58074092	D1401_0_3649	24	0	58170947	E0301_1_65025	10	1		H0302_0_4484	5/2	0

SPARE PARTS INSTANCE INDEX

Code	Parts Table	Pos.	Q.ty	Code	Parts Table	Pos.	Q.ty	Code	Parts Table	Pos.	Q.ty
58172043	B0501_1_42781	13	1	58172707	I0102_0_4552	2	0	58173790	D0801_0_3420	4	0
58172044	D1201_0_3551	12	0	58172773	A0401_0_2427	1.1	0		D0801_1_72999	4	1
58172155	C0202_2_64535	34	1	58172907	G0202_1_65175	48/2	1	58173792	D0801_0_3420	5	0
58172267	B0501_1_42781	6.2	1		H0202_0_4405	52/2	0		D0801_1_72999	5	1
	E0301_1_65025	1.2	1	58172978	H0401_0_4504	3	0	58173797	D0701_2_72962	18	1
58172274	G0303_0_4180	1	0	58172979	H0401_0_4504	4	0	58173864	H0401_0_4504	11/1	0
58172304	G0202_1_65175	21.1	1	58172980	H0401_0_4504	5	0	58173865	H0401_0_4504	11/2	0
	G0302_0_4169	1	0	58172982	H0401_0_4504	9	0	58173866	H0401_0_4504	2	0
	G0303_0_4180	1.1	0	58173116	B0501_1_42781	24.1	1	58174019	F0103_0_3917	24	0
	H0202_0_4405	21	0		B0501_1_42781	25.1	1	58174192	D0901_2_72753	1	1
	H0302_0_4484	1	0	58173117	H0401_0_4504	5.1	0	58174356	A0301_1_63276	11	1
	I0102_0_4552	8	0	58173118	H0401_0_4504	4.1	0	58174414	F0103_0_3917	13/1	1
58172350	D1401_0_3649	41	0	58173119	B0501_1_42781	24.2	1	58175700	E0301_1_65025	20	1
58172351	D1401_0_3649	41.1	0		B0501_1_42781	25.2	1	58175769	B0501_1_42781	11	1
58172400	D1401_0_3649	18	0		H0401_0_4504	5.2	0	58175770	B0501_1_42781	12	1
58172402	D1401_0_3649	19	0	58173120	B0501_1_42781	24.3	1	58175771	B0501_1_42781	10	1
58172447	D1401_0_3649	20	0	58173121	B0501_1_42781	25.3	1	58175773	E0201_0_3784	2	1
58172448	D1401_0_3649	21	0	58173122	H0401_0_4504	5.3	0	58175937	D0701_2_72962	10	1
58172463	D1501_0_3724	2	0	58173123	H0401_0_4504	4.2	0	58176290	A0301_1_63276	1.1	1
	E0301_1_65025	17	1	58173143	H0202_0_4405	22	0	58176294	L0201_0_4601	10	1
58172489	G0202_1_65175	21.3	1		H0302_0_4484	2	0		L0202_0_4630	17	1
	G0302_0_4169	3	0		I0102_0_4552	10	0	58176717	F0103_0_3917	1	1
	G0303_0_4180	3	0	58173144	H0401_0_4504	1	0	58177722	B0602_0_63791	1	1
	H0302_0_4484	3	0	58173361	G0303_0_4180	1.4	0	58177758	F0103_0_3917	13/2	1
	I0102_0_4552	9	0	58173399	D1501_0_3724	12	0	58178703	A0301_1_63276	1	1
58172490	G0202_1_65175	21.4	1		E0301_1_65025	18	1	58178731	A0301_1_63276	1.2	1
	G0303_0_4180	5/1	0	58173437	B0604_0_63758	4	1	58178960	D0503_0_3281	24	1
	H0302_0_4484	5/1	0	58173442	A0101_1_63226	1.4	1	58179262	D0701_2_72962	8	1
58172571	D0801_0_3420	11	0		A0102_1_63249	1.4	1	58179667	W0101_0_65465	1/1	1
	D0801_1_72999	11	1	58173493	C0202_2_64535	37	1	58179668	W0101_0_65465	1/2	1
58172589	D1501_0_3724	21/2	0	58173495	C0102_0_2927	5	0	58179928	D0601_2_72925	7	1
	H0202_0_4405	35	0	58173636	G0202_1_65175	1	1	58192377	B0602_0_63791	3	1
58172607	G0202_1_65175	48/1	1		H0202_0_4405	1	0		B0604_0_63758	13	1
	H0202_0_4405	52/1	0	58173790	D0701_2_72962	5	1	581A0108	C0302_1_72740	3	1



SPARE PARTS INSTANCE INDEX

Code	Parts Table	Pos.	Q.ty	Code	Parts Table	Pos.	Q.ty	Code	Parts Table	Pos.	Q.ty
581A0143	W0101_0_65465	14.1	1	59071786	M0101_1_65511	19	1	59072754	D1402_0_3708	1/1	0
581A0144	W0101_0_65465	14.2	1	59071807	L0203_0_4662	4	0	59072761	D1302_0_3629	4	0
581A0152	W0101_0_65465	10.1	1	59071808	D1201_0_3551	30	0		D1402_0_3708	4	0
581A0153	W0101_0_65465	10.2	1	59071809	D1201_0_3551	25	0	59072779	D1501_0_3724	20	0
581A0158	W0101_0_65465	7.1	1	59071955	B0301_0_2700	7/1	0	59072780	D1501_0_3724	18/1	0
581A0159	W0101_0_65465	7.2	1	59071956	B0301_0_2700	6/1	0	59072782	D1501_0_3724	18/2	0
581A0367	W0101_0_65465	1.1	1	59072006	D1201_0_3551	6	0	59072783	D1501_0_3724	19	0
581A0368	W0101_0_65465	1.2	1	59072007	D1201_0_3551	5	0	59072785	G0202_1_65175	17/2	1
581A0379	B0501_1_42781	2	1	59072008	D1201_0_3551	1	0		H0202_0_4405	17/2	0
581A0460	D0701_2_72962	2	2	59072057	G0202_1_65175	25	1	59072787	G0303_0_4180	13	0
59070448	L0201_0_4601	12	0		G0303_0_4180	4	0		H0302_0_4484	14	0
	L0202_0_4630	19	0		H0202_0_4405	29	0	59072788	D1501_0_3724	14	0
	L0203_0_4662	12	0		H0302_0_4484	4	0	59072790	D1501_0_3724	16/1	0
59070591	B0301_0_2700	10	0	59072114	B0301_0_2700	13	0	59072791	D1501_0_3724	16/2	0
59070592	B0203_0_2593	47	0	59072131	B0301_0_2700	6/2	0	59072826	G0202_1_65175	52	1
59071147	B0301_0_2700	1	0	59072140	B0301_0_2700	7/2	0		H0202_0_4405	56	0
59071241	B0602_0_63791	13	1	59072145	G0202_1_65175	17/1	1	59072893	G0202_1_65175	39/2	1
59071518	D0102_0_3082	21	0		H0202_0_4405	17/1	0		H0202_0_4405	43/2	0
	D1001_0_3471	12	0	59072167	D0503_0_3281	8	0	59072974	F0103_0_3917	2	0
59071640	D0301_0_3162	7	1	59072169	D0503_0_3281	6	0	59073021	H0302_0_4484	10	0
59071676	D1302_0_3629	15	0	59072275	L0202_0_4630	5	0	59073045	L0201_0_4601	4	0
59071724	D0503_0_3281	1	0	59072276	L0202_0_4630	4	0	59073060	H0401_0_4504	7	0
59071752	D0301_0_3162	1	1	59072330	L0202_0_4630	10	0	59073151	L0301_0_4690	8	0
59071769	A0201_0_2357	9	0	59072334	L0202_0_4630	9	0	59073160	G0202_1_65175	33	1
59071771	G0101_0_3995	14	0	59072347	L0202_0_4630	13	0		H0202_0_4405	34	0
	H0101_0_4286	14	0	59072408	G0202_1_65175	42	1	59073373	L0301_0_4690	7	0
59071778	D1201_0_3551	13	0		H0202_0_4405	46	0	59073374	L0301_0_4690	9	0
59071779	D1201_0_3551	15	0	59072410	G0202_1_65175	39/1	1	59074179	D0901_2_72753	19/1	1
59071781	D1201_0_3551	17	0		H0202_0_4405	43/1	0	59074180	D0901_2_72753	18/1	1
59071783	G0101_0_3995	13	0	59072471	B0203_0_2593	45	0	59074181	D0901_2_72753	20	1
	H0101_0_4286	13	0	59072491	A0501_0_2443	10	0	59074248	B0203_0_2593	14	0
	M0101_1_65511	13	1	59072752	D1302_0_3629	12	0	59074262	B0203_0_2593	30	0
59071786	G0101_0_3995	19	0	59072753	D1402_0_3708	1/2	0	59074263	B0203_0_2593	31	0
	H0101_0_4286	19	0	59072754	D1302_0_3629	1	0	59074274	A0301_1_63276	5	1



SPARE PARTS INSTANCE INDEX

Code	Parts Table	Pos.	Q.ty	Code	Parts Table	Pos.	Q.ty	Code	Parts Table	Pos.	Q.ty
59074276	A0101_1_63226	2	1	59076172	B0301_0_2700	6/3	1	59273944	D1102_0_3525	9/2	0
	A0102_1_63249	2	1	59076181	B0301_0_2700	6/4	1	59274025	C0202_2_64535	1	1
59074277	A0102_1_63249	7	1	59076182	B0301_0_2700	7/4	1	59275946	D1401_0_3649	30	1
59074278	A0101_1_63226	7	1	59076413	B0203_0_2593	6/1	1	59279819	C0202_2_64535	26	1
59074279	A0401_0_2427	7/1	0	59076414	B0203_0_2593	6/2	1	59371466	D0102_0_3082	13	0
59074285V	B0203_0_2593	12	1	59076428V	B0203_0_2593	1/1	1	59373783	D1001_0_3471	4/1	1
59074286V	B0203_0_2593	13	1	59076432V	B0203_0_2593	2/1	1	59375017	L0302_0_4700	1	0
59074308	A0401_0_2427	7/2	0	59077134V	B0203_0_2593	1/2	1	59379589	D1501_0_3724	29	1
59074326	B0203_0_2593	34	0	59077135V	B0203_0_2593	2/2	1	593A0890	D1001_0_3471	4/2	1
59074327	B0203_0_2593	35	0	59078588	L0201_0_4601	27/2	1	59900144	A0401_0_2427	1.2	0
59074343	D1501_0_3724	16/3	0		L0202_0_4630	22/2	1	59900145	A0401_0_2427	1.3	0
59074391	B0203_0_2593	21	0		L0203_0_4662	27/2	1	59900146	A0401_0_2427	1.4	0
59074412	G0202_1_65175	10	1	59079728	D0601_2_72925	20	1	59900147	A0401_0_2427	1.5	0
	H0202_0_4405	10	0	590A0695	B0701_1_65937	1	1	59900152	B0602_0_63791	15	1
59074413	G0202_1_65175	6	1	590A0698	B0701_1_65937	12	1	59900153	B0602_0_63791	9	1
	H0202_0_4405	6	0	590A0728	L0201_0_4601	21/2	1	59900154	B0602_0_63791	8	4
59074664	H0202_0_4405	36	0		L0202_0_4630	23/2	1	59900155	B0602_0_63791	7/1	1
59075012	L0302_0_4700	1.3	0		L0203_0_4662	21/2	1	59900156	B0602_0_63791	6	1
59075081	B0203_0_2593	29	1	590A0885	C0302_1_72740	10	1	59900157	B0602_0_63791	11	1
59075283	B0101_0_2468	18	1	59271011	D1501_0_3724	3	0	59900158	B0602_0_63791	10	18
59075386	G0202_1_65175	30	1	59271501	D0201_0_3112	10	0	59900159	B0602_0_63791	5	1
59075443	D0503_0_3281	20	1	59271720	D0201_0_3112	31	0	59900160	B0602_0_63791	12	1
59075446	D0503_0_3281	29	1	59271729	W0101_0_65465	10/1	1	59900161	B0602_0_63791	14	1
59075467	M0101_1_65511	21	1	59271732	W0101_0_65465	7/1	1	59900178	F0103_0_3917	24.1	0
59075476	M0101_1_65511	29	1	59271888	W0101_0_65465	14/1	4	59900180	G0101_0_3995	16.1	0
59075512	M0101_1_65511	14	1	59272323	L0202_0_4630	3	0		H0101_0_4286	16.1	0
59075593	G0303_0_4180	10	1	59272425	D1401_0_3649	47	0	59900181	G0101_0_3995	16.2	0
59075711	C0202_2_64535	20	1	59272426	D1401_0_3649	16	0		H0101_0_4286	16.2	0
59075712	C0202_2_64535	22	1	59272488	D0203_1_43188	5/2	1	59900183	B0604_0_63758	5	1
59075765	B0301_0_2700	16	1		D0203_2_72897	5/2	1	59900184	B0604_0_63758	6	1
59075766	B0301_0_2700	17	1	59273878	D1102_0_3525	9/1	0	59900185	B0604_0_63758	7	1
59076058	C0202_2_64535	8	1	59273937	W0101_0_65465	10/2	1	59900186	B0604_0_63758	8	1
59076160	M0101_1_65511	27	1	59273938	W0101_0_65465	7/2	1	59900187	B0604_0_63758	9	1
59076171	B0301_0_2700	7/3	1	59273939	W0101_0_65465	14/2	1	59900192	A0101_1_63226	1.1	1

SPARE PARTS INSTANCE INDEX

Code	Parts Table	Pos.	Q.ty	Code	Parts Table	Pos.	Q.ty	Code	Parts Table	Pos.	Q.ty
59900192	A0102_1_63249	1.1	1	F0256612913	H0202_0_4405	9	0	F0802187050	D0201_0_3112	2	0
59900193	A0101_1_63226	1.2	1	F0256808000	B0203_0_2593	42	0	F0802190010	D0102_0_3082	8	0
	A0102_1_63249	1.2	1	F0256809050	A0301_1_63276	8	1		D1301_0_3604	16	0
59900194	A0101_1_63226	1.3	1	F0800056050	D0202_2_72891	4	1		D1401_0_3649	12	0
	A0102_1_63249	1.3	1		D0203_1_43188	6	1	F0802700150	D1102_0_3525	1	0
59900195	A0101_1_63226	1.6	1		D0203_2_72897	6	1	F0803072050	D1501_0_3724	30	0
59900196	A0102_1_63249	1.6	1	F0801028000	D0201_0_3112	23	0	F0803178000	D1201_0_3551	32	0
59900199	B0604_0_63758	1	1	F0801050000	M0101_1_65511	26	1	F0803185000	F0103_0_3917	12	0
59900224	D0201_0_3112	1	0	F0801094000	D0201_0_3112	28	0		G0202_1_65175	5	1
59900225	H0202_0_4405	22.3	0	F0801095000	D0503_0_3281	26	0		H0202_0_4405	5	0
59900231	H0202_0_4405	22.1	0	F0801149010	G0101_0_3995	18	0	F0803186000	D0401_0_3186	5	0
59900232	H0202_0_4405	22.2	0		H0101_0_4286	18	0		D1401_0_3649	45	0
59900242	E0301_1_65025	1.3	1		M0101_1_65511	18	1	F0803204000	D1501_0_3724	31	0
59900247	F0103_0_3917	24.2	0	F0801156050	D0203_1_43188	3	1	F0803209000	D1202_0_3587	2	0
59900248	B0101_0_2468	1/1	0		D0203_2_72897	3	1	F0803286045	D1401_0_3649	37	0
59900249	B0101_0_2468	1/2	0	F0801175050	D0102_0_3082	25	0	F0804051000	D1201_0_3551	31	0
59900250	B0101_0_2468	1/3	0		D1001_0_3471	20	0	F0804052000	D1201_0_3551	14	1
59900251	B0101_0_2468	1/4	0	F0801241010	D0201_0_3112	9	0	F0806533000	D0503_0_3281	7	0
59901049	B0602_0_63791	4	1		D0601_2_72925	1	1	F0808060100	L0201_0_4601	22	0
59901050	B0602_0_63791	2	1		D1401_0_3649	13	0		L0202_0_4630	24	0
59901293	W0101_0_65465	14/3	1	F0801264050	D1301_0_3604	12	0		L0203_0_4662	22	0
59901294	W0101_0_65465	1.3	1		D1401_0_3649	8	0	F0808518050	B0401_0_2718	11	0
59901295	W0101_0_65465	7.3	1		G0101_0_3995	15	0	F0810505010	D1201_0_3551	11	0
	W0101_0_65465	10.3	1		H0101_0_4286	15	0	F0810510000	D0301_0_3162	6	0
F0060031247	L0203_0_4662	10	0		M0101_1_65511	15	1		D0401_0_3186	8	0
F0150010905	W0101_0_65465	11	1	F0801266000	D0601_2_72925	14	4		D0503_0_3281	16	0
F0150036216	B0604_0_63758	2	1	F0801266050	D0601_2_72925	8	2	F0810527000	D1201_0_3551	29	0
F0150036219	B0604_0_63758	3	1	F0801280100	D0701_2_72962	9	1	F0810617050	L0202_0_4630	7	0
F0190018909	E0201_0_3784	11	0	F0801297000	G0303_0_4180	26	0	F0812525100	D1401_0_3649	5	0
F0190031203	L0201_0_4601	21/1	1		I0102_0_4552	19	0	F0812578050	D0203_1_43188	2	1
	L0202_0_4630	23/1	1	F0801331050	D0601_2_72925	19	1		D0203_2_72897	2	1
	L0203_0_4662	21/14	1	F0801346000	D1102_0_3525	6	0	F0812599090	D1401_0_3649	7	0
F0190035152	E0301_1_65025	22	1	F0801346200	D0601_2_72925	12	4	F0812631000	D1001_0_3471	3	0
F0256612913	G0202_1_65175	9	1	F0801408000	D0201_0_3112	4	0	F0812686100	D0701_2_72962	14	1

SPARE PARTS INSTANCE INDEX

Code	Parts Table	Pos.	Q.ty	Code	Parts Table	Pos.	Q.ty	Code	Parts Table	Pos.	Q.ty
F0812689000	D0801_0_3420	6	0	F0814585000	A0401_0_2427	3	0	F0824110000	H0302_0_4484	12	0
	D0801_1_72999	6	2		B0101_0_2468	10	0		I0102_0_4552	7	0
F0812709000	D0801_0_3420	2	0	F0814621000	C0202_2_64535	9	1	F0824141000	F0103_0_3917	6	0
F0812732080	D0701_2_72962	16	1	F0814627000	D0301_0_3162	10	1		G0303_0_4180	24	0
F0812736010	D0601_2_72925	15	1		H0101_0_4286	26	0		I0102_0_4552	17	0
	D1401_0_3649	15	0	F0814629010	B0101_0_2468	6	0	F0824185000	G0202_1_65175	46	1
F0812737000	D0601_2_72925	5	3	F0814647000	C0202_2_64535	5	1		H0202_0_4405	50	0
F0812747000	C0202_2_64535	25	1	F0814689020	D0401_0_3186	13	0	F0824812000	A0101_1_63226	1.5	1
F0812750000	D0601_2_72925	2	1		D0503_0_3281	19	0		A0102_1_63249	1.5	1
F0812779000	D1301_0_3604	6	0	F0814689050	D0201_0_3112	7	0	F0825115010	B0501_1_42781	9	1
F0812849100	D1301_0_3604	14	0	F0814695000	C0302_1_72740	5	1	F0825139000	E0301_1_65025	1.4	1
	D1401_0_3649	10	0	F0814797000	D1401_0_3649	46	0	F0825400060	B0501_1_42781	8	1
F0812871030	D0701_2_72962	21	2	F0817512000	A0501_0_2443	15	0	F0825403050	B0501_1_42781	17	1
F0812895000	C0102_0_2927	13	0	F0817514000	G0202_1_65175	8	1	F0825404050	E0101_0_3772	2	0
	D1001_0_3471	13	0		H0202_0_4405	8	0	F0825414000	E0301_1_65025	14	1
F0812918050	D0701_2_72962	13	1	F0817523010	H0202_0_4405	44	0	F0825417000	E0101_0_3772	9	0
	D0801_0_3420	8	0	F0817530200	G0202_1_65175	40	1	F0825420500	E0101_0_3772	6	0
	D0801_1_72999	8	1	F0817535000	A0301_1_63276	2	1	F0825420560	E0101_0_3772	6.1	0
F0812973000	D1102_0_3525	2	0	F0817568000	A0401_0_2427	5	0	F0825420600	E0301_1_65025	11	1
F0814525000	A0101_1_63226	15	1	F0817568100	A0401_0_2427	6	0	F0825420660	E0301_1_65025	11.1	1
	A0102_1_63249	15	1	F0819180080	D0201_0_3112	25	0	F0825436000	B0501_1_42781	6.3	1
	E0201_0_3784	7	0	F0822537050	D0301_0_3162	3	0		E0301_1_65025	1.5	1
	E0301_1_65025	5	1		D0503_0_3281	12	0	F0825436003	B0501_1_42781	6.4	1
F0814529080	E0101_0_3772	7	0	F0824022000	F0103_0_3917	11	0		E0301_1_65025	1.6	1
	E0301_1_65025	13	1		G0202_1_65175	15	1	F0825438000	E0301_1_65025	3	1
F0814535050	D1201_0_3551	26	0		H0202_0_4405	15	0	F0825469050	E0201_0_3784	8	0
	H0101_0_4286	42	0	F0824110000	C0202_2_64535	15	1	F0825488000	E0301_1_65025	7	1
F0814569000	M0101_1_65511	24	1		D1501_0_3724	22	0	F0825493000	E0301_1_65025	21	1
F0814574000	A0501_0_2443	7	0		F0103_0_3917	18	0	F0825718000	G0202_1_65175	45	1
	B0203_0_2593	10	0		F0103_0_3917	29	0		H0202_0_4405	49	0
	C0202_2_64535	36	1		G0202_1_65175	31	1	F0825718010	G0202_1_65175	45.1	1
	D0102_0_3082	2	0		G0303_0_4180	12	0		H0202_0_4405	49.1	0
	D1301_0_3604	19	0		G0303_0_4180	19	0	F0825718020	G0202_1_65175	45.2	1
	D1401_0_3649	51	0		H0202_0_4405	33	0		H0202_0_4405	49.2	0

SPARE PARTS INSTANCE INDEX

Code	Parts Table	Pos.	Q.ty	Code	Parts Table	Pos.	Q.ty	Code	Parts Table	Pos.	Q.ty
F0825809000	F0103_0_3917	8	0	F0838166018	D1401_0_3649	50	0	F0843570000	M0101_1_65511	35	1
	G0202_1_65175	13	1	F0838475000	C0102_0_2927	11	0	F0843605010	B0501_1_42781	21	1
	H0202_0_4405	13	0		C0202_2_64535	3	1	F0843641000	D1401_0_3649	49	0
F0825980030	G0303_0_4180	25	0	F0838535050	C0202_2_64535	4	1		D1501_0_3724	36	0
	I0102_0_4552	18	0	F0838660000	C0302_1_72740	4	1	F0843643060	A0101_1_63226	12	1
F0826056000	C0202_2_64535	10	1	F0842505030	F0103_0_3917	28	0		A0102_1_63249	12	1
	G0101_0_3995	2	0	F0842519050	G0202_1_65175	57	1		A0201_0_2357	5	0
	H0101_0_4286	2	0	F0843102000	D1501_0_3724	25	0		B0203_0_2593	9	0
	L0302_0_4700	1.6	0	F0843107000	D1501_0_3724	23	0		B0701_1_65937	13	1
	M0101_1_65511	2	1		G0202_1_65175	36	1		D0503_0_3281	23	0
F0828029070	A0201_0_2357	1	0		G0303_0_4180	21	0		D1201_0_3551	18	0
F0831125000	A0201_0_2357	12	0		H0202_0_4405	40	0		D1301_0_3604	21	0
F0831139000	D0301_0_3162	4	0		I0102_0_4552	14	0		D1302_0_3629	2	0
F0834378001	A0101_1_63226	1.7	1	F0843109000	F0103_0_3917	22	0		D1402_0_3708	2/1	0
	A0102_1_63249	1.7	1	F0843109020	D1501_0_3724	21/1	0		D1402_0_3708	2/2	0
	E0201_0_3784	4	0		F0103_0_3917	27	0		D1501_0_3724	9	0
F0835023000	G0202_1_65175	29	1		G0202_1_65175	32	1		G0202_1_65175	28	1
	G0303_0_4180	18	0		G0303_0_4180	11	0		G0302_0_4169	5	0
	I0102_0_4552	6	0		H0202_0_4405	32	0		G0303_0_4180	7	0
F0835024010	F0103_0_3917	17	0		H0302_0_4484	11	0		H0202_0_4405	24	0
F0835037000	F0103_0_3917	5	0	F0843526000	D1501_0_3724	28	0		H0302_0_4484	7	0
F0835040000	F0103_0_3917	19	0	F0843561000	A0101_1_63226	14	1		L0201_0_4601	14	0
F0835040020	G0303_0_4180	23	0		A0102_1_63249	14	1		L0202_0_4630	21	0
	I0102_0_4552	16	0		E0201_0_3784	6	0		L0203_0_4662	14	0
F0837534010	D1302_0_3629	6	0	F0843570000	A0301_1_63276	6	1	F0843696000	B0604_0_63758	12	6
	D1402_0_3708	6	0		B0203_0_2593	26	0	F0843755000	A0301_1_63276	10	1
	G0202_1_65175	24	1		B0301_0_2700	20	1		A0501_0_2443	12	0
	G0302_0_4169	9	0		B0501_1_42781	22	1		B0101_0_2468	7	0
	G0303_0_4180	17	0		D1201_0_3551	8	0		B0203_0_2593	16	0
	H0202_0_4405	28	0		D1501_0_3724	6	0		C0102_0_2927	10	0
	H0302_0_4484	18	0		D1501_0_3724	11	0		C0202_2_64535	7	1
F0837534060	D1302_0_3629	13	0		G0202_1_65175	12	1		D0503_0_3281	5	0
F0838131000	D1301_0_3604	18	0		H0101_0_4286	23	0		F0103_0_3917	4	0
F0838166018	D1301_0_3604	20	0		H0202_0_4405	12	0	F0843771000	D1501_0_3724	26	0

SPARE PARTS INSTANCE INDEX

Code	Parts Table	Pos.	Q.ty	Code	Parts Table	Pos.	Q.ty	Code	Parts Table	Pos.	Q.ty
F0843818000	B0203_0_2593	17	0	F0848844000	W0101_0_65465	15	1	F0852589000	H0202_0_4405	59	0
F0843841000	D1501_0_3724	13	0	F0848855000	W0101_0_65465	8	1	F0854067050	B0401_0_2718	14	0
	E0301_1_65025	19	1	F0848887000	W0101_0_65465	4	1	F0858520000	A0201_0_2357	15	1
F0843843060	A0101_1_63226	6	1	F0849206005	A0301_1_63276	4	1	F0861867050	A0501_0_2443	4	0
	A0102_1_63249	6	1	F0849211010	B0101_0_2468	5	0	F0861929060	A0101_1_63226	13	1
	B0301_0_2700	9	0	F0849500001	A0501_0_2443	1.1	0		A0102_1_63249	13	1
	B0301_0_2700	15	0	F0849500002	A0501_0_2443	1.2	0		D0901_2_72753	32	1
	L0201_0_4601	8	0	F0850104000	D0201_0_3112	20	0		E0201_0_3784	5	0
	L0202_0_4630	30	0	F0850104010	D0201_0_3112	20	0		H0101_0_4286	27	0
	L0203_0_4662	8	0	F0850104020	D0201_0_3112	20	0		H0401_0_4504	8	0
F0843907000	D1501_0_3724	24	0	F0851018000	D1401_0_3649	40	0	F0861941000	E0301_1_65025	4	1
	G0202_1_65175	37	1	F0851180000	D0901_2_72753	17	1	F0862090000	D1102_0_3525	8	0
	G0303_0_4180	22	0		D1302_0_3629	16	0	F0862210000	C0202_2_64535	44	1
	H0202_0_4405	41	0	F0851226000	D1401_0_3649	31	0	F0862345000	D1501_0_3724	5	0
	I0102_0_4552	15	0	F0851260000	D1201_0_3551	23	0		G0202_1_65175	11	1
F0843921030	B0101_0_2468	16	0		D1202_0_3587	12	0		H0202_0_4405	11	0
F0843948000	D1501_0_3724	4	0	F0851267050	D1201_0_3551	35	0	F0862443010	H0101_0_4286	37	0
	F0103_0_3917	23	0		D1202_0_3587	6	0		M0101_1_65511	45	1
F0843993060	W0101_0_65465	19	1	F0851486000	L0201_0_4601	17	0	F0862448100	D1401_0_3649	48	0
F0844030070	E0201_0_3784	3	0		L0202_0_4630	12	0		D1501_0_3724	37	0
F0844150000	W0101_0_65465	3	3		L0203_0_4662	17	0	F0862462010	F0103_0_3917	10	0
F0844200050	D1501_0_3724	33	0		L0301_0_4690	3	0		G0202_1_65175	14	1
F0844273090	C0102_0_2927	4	0		L0302_0_4700	1.5	0		H0202_0_4405	14	0
	D1102_0_3525	15	0	F0851497000	B0101_0_2468	19	1	F0862464050	A0501_0_2443	21	0
F0844283020	L0201_0_4601	2	0		L0201_0_4601	23	0	F0862473050	D1401_0_3649	44	0
	L0203_0_4662	2	0		L0202_0_4630	25	0	F0862479020	B0501_1_42781	15	1
F0847434000	D0901_2_72753	23	1		L0203_0_4662	23	0	F0862479030	B0203_0_2593	7	0
	D1302_0_3629	8	0		L0301_0_4690	2	0	F0862481000	B0701_1_65937	11	1
	D1402_0_3708	8	0	F0852516020	D1202_0_3587	16	0	F0862495010	B0604_0_63758	11	4
F0848635000	W0101_0_65465	5	1	F0852550010	G0303_0_4180	27	0	F0862593050	C0202_2_64535	35	1
F0848648000	W0101_0_65465	6	1		I0102_0_4552	20	0	F0862655000	D1102_0_3525	13	0
F0848655000	W0101_0_65465	9	1	F0852578050	C0202_2_64535	14	1	F0862657000	D0102_0_3082	3	0
F0848672100	W0101_0_65465	16	1	F0852578060	H0302_0_4484	13	0	F0862694000	D0901_2_72753	28	1
F0848679600	W0101_0_65465	13	4	F0852589000	G0202_1_65175	55	1	F0863097150	A0501_0_2443	8	0

SPARE PARTS INSTANCE INDEX

Code	Parts Table	Pos.	Q.ty
F0863105000	C0202_2_64535	13	1
	D0901_2_72753	22	1
F0863114000	B0501_1_42781	19	1
F0863267050	C0202_2_64535	23	1
	D0102_0_3082	14	0
	D1001_0_3471	5	0
F0863328000	G0101_0_3995	7	0
F0863358000	H0101_0_4286	7	0
	M0101_1_65511	7	1
F0863359000	C0202_2_64535	2	1
F0864309100	B0301_0_2700	4	0
F0864314000	W0101_0_65465	18	1
F0864322100	M0101_1_65511	36	1
F0864351050	B0101_0_2468	13	0
F0864410500	W0101_0_65465	2	3
F0865040000	B0501_1_42781	1	1
F0865040010	B0501_1_42781	26	1
F0907170114	B0401_0_2718	18/1	0
F0907170115	B0401_0_2718	18/2	0
F1000005108	E0101_0_3772	3	0
P241171000000	G0202_1_65175	56	1
	H0202_0_4405	37	0
P295332000000	D1201_0_3551	2	0